

Reshaping  
your  
world.

**NORTON**

SAINT-GOBAIN

ABRASIVE SOLUTIONS

# INDUSTRIAL APPLICATIONS

**2017**

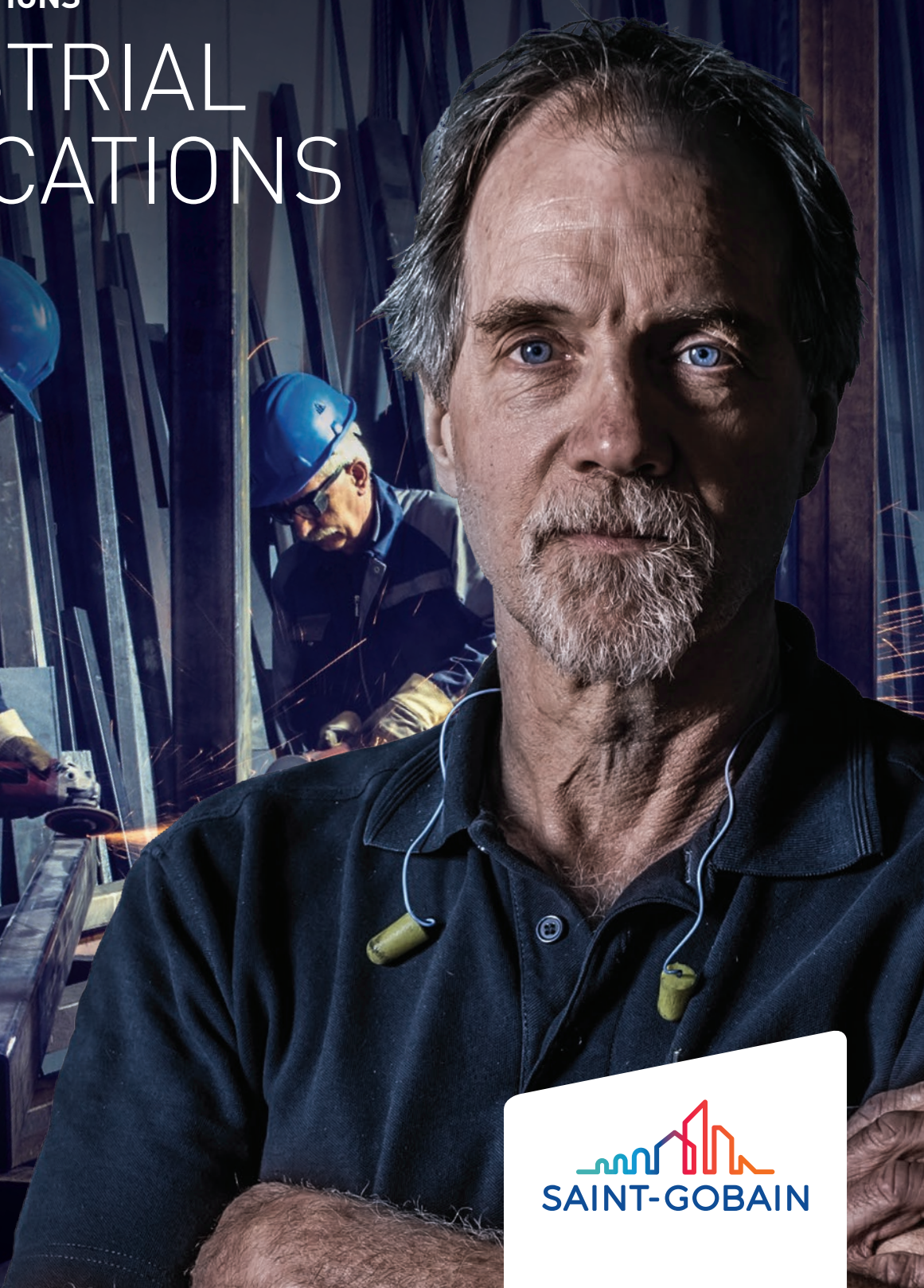

  
SAINT-GOBAIN





**NORTON**

SAINT-GOBAIN<sup>®</sup>

## **RESHAPING YOUR WORLD WITH...**

WORLDWIDE MARKET LEADERSHIP

WORLD CLASS PRODUCT INNOVATIONS

CUTTING EDGE TECHNOLOGIES

A COMPLETE RANGE OF STOCK PRODUCTS

THE WIDEST SPECTRUM OF PRODUCT QUALITY

MADE-TO-ORDER SOLUTIONS







CUTTING-OFF  
& GRINDING  
WHEELS

COATED  
ABRASIVES  
& BEARTEX

BONDED  
ABRASIVES

SUPER  
ABRASIVES

DIAMOND  
TOOLS

CLEANING,  
POLISHING  
& MASKING

PERSONAL  
PROTECTION  
EQUIPMENT

TECHNICAL  
INFORMATION

Reshaping  
your  
world.®



## INTRODUCTION

06	The Worlds Premium Abrasives Brand	16	Delivering Logistical Excellence	32	Merchandising Solutions
08	Abrasive Technological Excellence	17	A History Of Excellence	34	How To Use This Catalogue
11	Delivering Innovative Excellence	18	Patents & Trademarks	34	How To Order
14	Delivering Product Tiering	19	A Corporate Perspective		
15	Delivering Made-To-Order Solutions	20	Delivering a Sustainable Future		
		22	Abrasive Markets		

## CUTTING-OFF & GRINDING WHEELS

36	Introduction	63	Wheels for Petrol Saws	65	Wheels for Rail
40	Wheels for Angle Grinders	64	Wheels for Chop Saws	67	Wheels for Stationary Machines

## COATED ABRASIVES & BEARTEX NON-WOVENS

72	Index by Product	197	Orbital Straight Sheet Sander/ Sanding Block	265	Satinex Machine
73	Index by Machine Type	209	Hand Sanding	271	Wide Belts
74	Introduction	229	File Belt Machine	273	Products for wall, floor & ceiling sanding
89	Angle Grinder	235	Portable Belt Sander	285	Shoe Manufacture & Repair
117	Mini Grinder	239	Backstand Machine	289	Glass Arising
141	Die Grinder	251	Bench/Pedestal Grinder		
171	Disc Sanders				

## BONDED ABRASIVES

294	Introduction	355	Bench And Pedestral Grinding	393	Snagging Wheels & Cups
298	Application Guide	366	Vitrified Mounted Points	396	Organic Mounted Points
301	Tool Grinding	371	Dressing Sticks		
320	Saw Sharpening	374	Bench & Combination Oil Stones		
326	Surface Grinding	377	Abrasive & Precision Files		
342	External Cylindrical Grinding	382	Abrasive Slips & Specialties		
350	Internal Cylindrical Grinding	385	Cut-off Wheels		

## SUPER ABRASIVES

400	Introduction	425	Diamond Lapping Compounds	427	Diamond Dressers
402	Diamond & CBN Grinding Wheels	426	Diamond Files		

## DIAMOND TOOLS

436	Introduction	449	Petrol Hand Held & Floor Saws	456	Tile Saws
442	Angle Grinders	452	Masonry Saws	458	Core Bits

## CLEANING, POLISHING & MASKING

464	Introduction	477	Wire Brushes for Hand Drills	497	Steel Wool
469	Wire Brushes for Bench Grinders	480	Wire Brushes	498	Cleaning & Polishing Products
471	Wire Brushes for Angle Grinders	484	Tungsten Carbide Burrs	504	Masking Tapes

## PERSONAL PROTECTION EQUIPMENT

514	Introduction	519	Single Use Gloves	522	Overalls
516	Respiratory Masks	520	Glasses		

## TECHNICAL INFORMATION

524	Cutting-Off & Grinding Wheels	543	Beartex	566	Super Abrasives
532	Coated Abrasives	553	Bonded Abrasives	571	Diamond Blades



06-34

INTRODUCTION

35-70

CUTTING-OFF &  
GRINDING WHEELS

71-292

COATED ABRASIVES  
& BEARTEX  
NON-WOVENS

293-398

BONDED  
ABRASIVES

399-434

SUPER  
ABRASIVES

435-462

DIAMOND  
TOOLS

463-512

CLEANING,  
POLISHING  
& MASKING

513-522

PERSONAL  
PROTECTION  
EQUIPMENT

523-574

TECHNICAL  
INFORMATION

CUTTING-OFF  
& GRINDING  
WHEELS

COATED  
ABRASIVES  
& BEARTEX

BONDED  
ABRASIVES

SUPER  
ABRASIVES

DIAMOND  
TOOLS

CLEANING,  
POLISHING  
& MASKING

PERSONAL  
PROTECTION  
EQUIPMENT

TECHNICAL  
INFORMATION



# Reshaping your world®

Norton, the world's premium abrasive brand, offers powerful, precise and user friendly solutions enabling our customers to shape and surface-finish all types of materials even in the most complex and challenging applications.

As the technology leader, Norton sits at the forefront of the industry providing highly engineered, high-performance value-adding abrasives.

Norton's continual investment in R&D and close collaboration with customers generates highly performance-optimised innovations.

This strong commitment ensures that exciting new products are continuously introduced which offer substantial customer benefits. Helping to improve process productivity and reshape the world of abrasive solutions.







### UTILISING NEW TECHNOLOGIES

As well as New Product Development, Norton is committed to utilising technology breakthroughs in all its existing products. Both the Norton stock range and made-to-order solutions are continually reviewed to ensure that the product offer remains fresh and conforms to the most recent market trends. This approach ensures that all Norton products benefit from state-of-the-art technology, and that the Norton brand has continued sustainable market growth.

### INNOVATION AT WORK

Norton reinforces its position as market and innovation leader by constantly analysing the market to ensure it continuously fulfils customer needs. Norton looks to acquire and hold extensive knowledge about its customers' business activities and product priorities. This market orientated approach enables Norton to better anticipate customer requests and to have an improved understanding of market developments.

### THE ABRASIVE EXPERTS

Norton's technical expertise ensures not only are the most appropriate products used in all abrasives applications but also they are used in an effective and safe manner, maximising performance. Through this Norton looks to establish valuable working partnerships with its customers of all sizes and stature.

### COMMITTED TO CUSTOMER NEEDS

These working partnerships are reinforced through extensive marketing activities that support its complete and innovative product range. Norton is much more than the world's leading manufacturer of abrasive products, it's a brand that has become and remains number one in the minds of its customers. Norton is committed to the long-term development of abrasives and is part of a company that looks to assist customers in all their abrasive needs.

# ABRASIVE TECHNOLOGICAL EXCELLENCE

NORTON'S RELENTLESS COMMITMENT TO DELIVERING TECHNOLOGICAL EXCELLENCE IS REINFORCED THROUGH ITS "CENTRES OF EXCELLENCE".



Since Norton's first breakthrough, in 1885, research efforts have continued to produce industry leading results. At the start of the 20th Century Norton's first innovation was the invention of Norton's trademark Alundum abrasive grain, an aluminium oxide grain that could be manufactured to meet precise grinding requirements.

Throughout the 20th and early 21st Centuries Norton has increased its research efforts by developing

innovative products made with new grains including, aluminium oxide, zirconium oxide (Norzon), Seeded Gel (SG) and IPA (Vortex).

Today, Norton's relentless commitment to Delivering Technological Excellence is reinforced through its "Centres of Excellence". Positioned across the globe, each centre concentrates on the development of exciting new products and grains for all applications found within one type of abrasives.



**OUR WORLD GRINDING TECHNOLOGY CENTRE IS DEDICATED TO THE ADVANCEMENT OF GRINDING TECHNOLOGY AND ABRASIVE PRODUCT PERFORMANCE.**

## BONDED ABRASIVES

Opened in 1993, the World Grinding Technology Centre in Worcester, Massachusetts, USA, is Norton's premier research centre for Bonded Abrasives products. In 1998, the centre was renamed as the Higgins Grinding Technology Centre, in honour of the late Milton P. Higgins, a member of one of the founding families of Norton.

The centre is dedicated to the advancement of grinding technology and abrasive product performance, using structured R&D that focuses on grinding system solutions, coolant system solutions, and process diagnostics and optimisation. The centre conducts regular training sessions promoting a systems orientated education focusing on new process development, and increasing the awareness of new product technology. The centre enables Norton to set the standard for Bonded Abrasive product performance throughout the worldwide abrasives industry.



## SUPER ABRASIVES

The Norderstedt European Grinding Technology Centre (EGTC), founded in 2001, is located at the Saint-Gobain Abrasives Diamantwerkzeuge production plant in Norderstedt, Germany. Since opening, the EGTC has played a key role in new grinding wheel and process technology development for Super Abrasive and Bonded products.

The centre brings together the expertise of Super Abrasive and Bonded specialists who have a profound understanding of the complex grinding system, with innovative measurement and analysis tools which enables detailed investigation of grinding wheel performance and complex tool-workpiece interactions.

The EGTC conducts short-term customer application projects in close collaboration with the Saint-Gobain Abrasive application engineering team, who have a strong European presence. As well as this, long-term projects targeting more complex tasks are frequently performed by the centre. The centre allows research teams, consisting of end-users, grinding wheel manufacturers and machine manufacturers, to meet in one place. This enables fast, sustainable and economical solutions for all Super Abrasive applications. The EGTC possesses a number of modern CNC grinding and consignment machine tools to deal with the different applications found in a global market.

The attitude at the centre is highlighted by the numerous seminars and training sessions conducted each year, for both Saint-Gobain Abrasives employees and Norton customers from across the globe.



**THE NORDERSTEDT EUROPEAN GRINDING TECHNOLOGY CENTRE (EGTC), BRINGS TOGETHER THE EXPERTISE OF SUPER ABRASIVE & BONDED SPECIALISTS WHO HAVE A PROFOUND UNDERSTANDING OF COMPLEX GRINDING SYSTEMS, WITH INNOVATIVE MEASUREMENT & ANALYSIS TOOLS.**



**THE HIGHLY SOPHISTICATED TEST CENTRE HAS ADVANCED TRAINING FACILITIES.**

## CUTTING-OFF & GRINDING WHEELS

The Saint-Gobain Abrasives Centre of Excellence in Eibergen, Netherlands has outstanding experience in testing Cutting-off and Grinding wheels. The highly sophisticated test centre has advanced training facilities with a range of carefully selected, up-to-date machines enabling tests to be carried out on the most common application materials. It is possible to test all wheels in the Norton range from diameter 76mm to 406mm, analysing cutting performance, grinding performance, and wheel safety.

The test centre also contains a state-of-the-art robot, which, when used by the centre's expertly trained operators, enables highly reliable test figures to be produced in clear test reports. This not only helps Norton sales teams sell products but also supports Research and Development efforts.

Regular training sessions are also conducted for employees and customers which cover both the theoretical and practical aspects of our products and their application. Regular presentations and demonstrations are given by our product and application specialists.

## COATED ABRASIVES

For more than 80 years our manufacturing plant, in Wesseling near Cologne, Germany, has been well-known for the development of Coated Abrasive products. Computerised production processes, high performance product specifications formulations and a long-standing quality management system give the required assurance for the high performance of all Wesseling manufactured products.

This long standing expertise has allowed Norton product and application engineers to have a superb understanding of the technical issues encountered during coated abrasive applications.

The Wesseling Technology Centre, due to be officially opened as a Centre of Excellence in 2007, features a state-of-the-art Automotive Aftermarket training centre including a spray booth that replicates the real life working environment of Body and Paint Shops.

The Technology Centre is also equipped with a high tech back stand grinder, down draft tables and selected hand tools, that allow focused application tests to take place. This gives Norton engineers the fullest and most accurate knowledge of applications using basic products to more high-tech engineered abrasives, such as Norax®.

The forward thinking approach adopted at Wesseling is passed to sales staff through regular training sessions, giving them a greater understanding of our products to pass on to our customers.

## DIAMOND BLADES

Norton's facilities in Bascharage, Luxembourg, host the Norton Diamond products state-of-the-art Centre of Excellence.

Ideally located in the centre of Europe, the facilities are used to offer regular training sessions to both staff and customers.

Visitors to the centre can learn about the best use for the different types of diamond blades, compare the different Norton ranges in the demonstration area, and learn about effective and safe methods of use. Using products and seeing them being used by experts not only helps provide a more memorable experience, but also helps people develop a greater understanding.

The showroom at Bascharage also gives visitors the opportunity to see the whole range of Norton Diamond Blades as well as every type of Clipper machine.

The centre is also a key resource for product development and testing. All new products are subjected to strenuous tests to gather accurate application and performance statistics.

This not only ensures product safety, it also ensures accurate information is gathered meaning products can be sold with confidence by our sales personnel. The test area is of-course equipped with a wide range of up-to-date equipment, to help measure and control product tests.



THE WESSELING CENTRE OF EXCELLENCE FEATURES A STATE-OF-THE-ART AUTOMOTIVE AFTERMARKET TRAINING CENTRE INCLUDING A SPRAY BOOTH THAT REPLICATES THE REAL LIFE WORKING ENVIRONMENT OF BODY AND PAINT SHOPS.



THE BASCHARAGE CENTRE OF EXCELLENCE IS A KEY RESOURCE FOR PRODUCT DEVELOPMENT AND TESTING. ALL NEW PRODUCTS ARE SUBJECTED TO STRENUOUS TESTS TO GATHER ACCURATE APPLICATION AND PERFORMANCE STATISTICS.



## DELIVERING INNOVATIVE EXCELLENCE



CUTTING EDGE INNOVATION MAKES NORTON QUANTUM GRINDING WHEELS LAST 50% TO 100% LONGER – DESIGNED FOR MAXIMUM PERFORMANCE AND COST SAVINGS.

Investing in R&D, stimulating the generation of new ideas, and increasing the speed at which cutting-edge science is turned into market-ready products, are identified as key factors that determine business success and are some of Norton's main business priorities.

Norton also takes an innovative approach to its business operations, and is committed to the continuous improvement processes and services, creating, evaluating and exploiting new ideas to help continuously add value to its customer relations.

Recently a number of product innovations have been introduced. These are clearly highlighted throughout this catalogue.

Norton's innovative abrasive solutions offer outstanding productivity and versatility, and help reinforce its position as the world's leading manufacturer of abrasives.

### NEW ABRASIVE TECHNOLOGY

**VITRIUM<sup>3</sup>**

#### REVOLUTIONARY BOND TECHNOLOGY

Through Saint-Gobain Abrasives' extensive research and development program in grinding wheel technology, comes Vitrium<sup>3</sup> a new generation, patent-pending bond.

This revolutionary bond platform features an exclusive chemistry that delivers an entirely new grain adhesion science, resulting in improved product versatility across a wide range of precision grinding applications.



#### THE ULTIMATE GRINDING EXPERIENCE

By combining three of the very best Norton patented technologies (Norton Quantum, Vortex2 and Vitrium<sup>3</sup>); Norton Quantum X grinding wheels provide maximum performance, increased productivity and reduced process costs.

Norton Quantum X grinding wheels are ideal for the most challenging applications including high material removal, heat sensitive and difficult to grind alloys and thin wall parts which may be sensitive to deformation.



## NEW PRODUCT INNOVATIONS



The perfect formulation of market feedback, our relentless commitment to end user comfort and a new infusion of technology brings this distinctive range of grinding wheels to the forefront.

The impressive cutting action doesn't compromise comfort as it effortlessly bites into metal.

Norton Quantum3's design delivers remarkable power and refined control from start to finish.

So you have smooth cutting performance to remove metal much faster while using fewer wheels for the job.



## INFILTRATED HIGH DENSITY DIAMOND BLADES

Norton's Infiltrated High Density technology (I-HD™) combined with its patented diamond blades laser-welding process is the biggest breakthrough in Diamond Tools this century.

Infiltration achieves high uniform density across each whole segment without applying high pressure (like the standard process). This allows Norton to manufacture very robust segments which wear evenly, remain intact and perform faster at higher cutting speeds.

Norton's optimized process also means increased segment design flexibility resulting in greater diversification of diamond blade shapes to best suit applications and materials being cut.

This revolutionary process provides our customers with:

- A faster tool cutting speed by +30%
- Longer product life by at least +20%
- Advanced safety breakthrough with a 100% warranty against segment loss
- A wider choice of segment design to suit a variety of applications and materials
- Greater user comfort

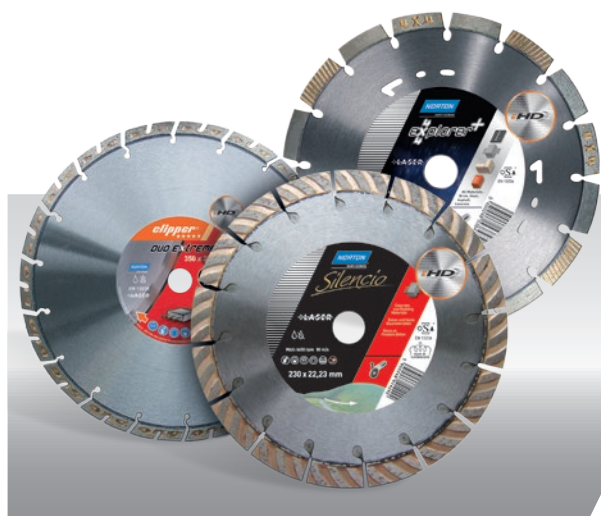



## NEW PRODUCT CONCEPTS

### VULCAN

#### FOR ALL INDUSTRIAL APPLICATIONS

Norton has a global reputation for its high quality and job focused abrasive products, and the new Vulcan range is no exception. With cutting-off and grinding wheels, flap discs and a range of diamond blades, Vulcan is a multi-solution provider, offering performance, value and convenience in all industrial applications.



#### FOR FOUNDRY APPLICATIONS

The new Norton Foundry X cut-off and grinding wheels have been specifically designed for heavy duty foundry applications and to perform on a range of tough materials.

The bond technology in Foundry X cut-off wheels provide greater heat resistance resulting in longer abrasive life, improves cut-rate and allows a shorter cycle time. The zirconia grains in the grinding wheels provide a high metal removal rate, reduced downtime and longer product life; making them ideal for using with high frequency angle grinders.



#### FOR SURFACE CONDITIONING

Vortex Rapid Prep Belts are the newest extension of the non-woven coated abrasive range for surface conditioning. These abrasive belts are used for blending, finishing and deburring in industries ranging from aerospace to metal fabrication, and MRO operations. They also include proprietary Clean Bond™ resin technology, resulting in a smear-free finish that improves productivity by eliminating rework.



#### PRECISION, SPEED AND POWER

The new long life ZA24Q rail cutting wheel has been specifically designed for use on steel and railway tracks, including subway, tram and train.

The sharp, high performance premium grain and innovative optimised bond technology provides a fast and precise cut. The wheel can be used on any rail cutting machine with a clamping device (electrical and petrol).



#### BELIVE IN PINK

Norton Quantum R928 high performance flap discs, with polycotton cloth backing and pink ceramic grain, provide an improved cut rate and product life compared to both premium zirconium discs and ceramic products in the market, thanks to its high density configuration. R928 also features an additional supersize layer giving this flap disc range cooler cutting properties, reducing heat generation during use for better part quality first and every time. R928 is the ideal flap disc for quick grinding when used at medium pressure on stainless steel or harder metals.

# DELIVERING GOOD, BETTER AND BEST SOLUTIONS

One size fit's all isn't for everyone and at Norton we believe in delivering the right choices that matter to you. Our abrasives are classified as Good, Better and Best performance/price tiers to help you chose the right product for your application, every time.



And clear graphics and communication help to visually differentiate between our Good, Better, and Best product solutions.



## STILL NEED A DIFFERENT CHOICE?

We also have products for the very basic need where the lowest initial price point is priority to get the job done. If you need help to determine the right tier for your specific needs, don't hesitate to contact us or via your local Norton sales representative.



## DELIVERING MADE-TO-ORDER SOLUTIONS

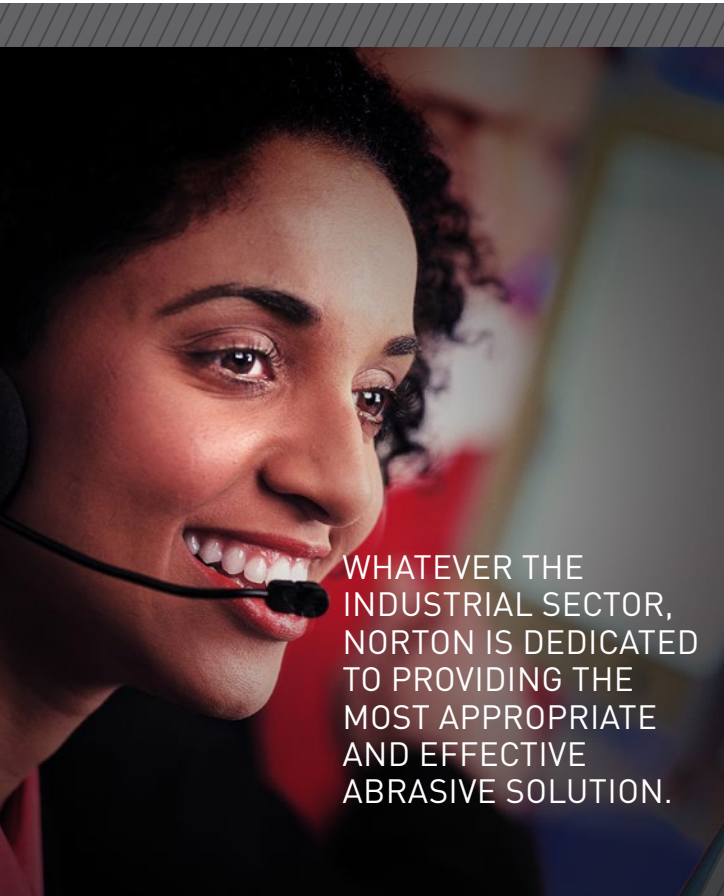

WHATEVER THE INDUSTRIAL SECTOR, NORTON IS DEDICATED TO PROVIDING THE MOST APPROPRIATE AND EFFECTIVE ABRASIVE SOLUTION.

### NORTON IS A UNIQUE SOLUTION PROVIDER

Whatever the industrial sector, Norton is dedicated to providing the most appropriate and effective abrasive solution for any application including cutting, grinding and polishing.

In addition to the thousands of stock products available in Coated, Bonded, Thin Wheels, Diamond Blades and Super Abrasives, Norton offers a large number of made-to-order products designed to meet any technical requirement.

Made-to-order solutions represent a significant amount of the complete Norton product offering.

When complex application environments have to be analysed, when cutting-edge technology is necessary to optimise product performances, our leading brand offers the premium solution.

Many Norton customers benefit from our technical support – facilitating the choice of abrasive and combining insight from both sides to run appropriate tests and improve processes.

Sharing views and experiences, Norton represents your preferred partner to increase productivity and reduce overall cost.

### WHY SELECT NORTON

- Our Centres of Excellence enable product testing under real conditions
- We have highly skilled, knowledgeable and experienced personnel devoted to delivering high performance solutions to fulfil customer needs
- We allocate time and resource to product testing/customer case studies
- We have acquired invaluable experience over our long history
- We establish client partnerships to ensure we are aware of the most up-to-date technology with regard to processes, machines and coolants.

To learn more about Norton made-to-order capabilities, highly effective engineered solutions, cutting edge technologies that can help you optimise performance and reduce costs, please contact your local Customer Service Department.

**HELP CUSTOMERS SELECT THE RIGHT ABRASIVE FROM OUR HUGE PRODUCT OFFERING AND DELIVER HIGHLY ENGINEERED SOLUTIONS THAT NOT ONLY MEET BUT EXCEED VERY SPECIFIC AND TECHNICAL REQUIREMENTS, IN ALL MARKET SEGMENTS.**

## DELIVERING LOGISTICAL EXCELLENCE

In order to confirm Norton's market leading position and support our highly engineered, innovative product solutions, Norton operates a range of ERP and Quality Management systems. This enables continuous improvement of performance at every stage of the logistic chain, through careful effective monitoring of all logistical processes and the subsequent implementation of new technology and best practice procedures.

**NORTON HAS A LOGISTICS TEAM OF 80 SPECIALISED PEOPLE WHO ARE DEDICATED AND FOCUSED ON SATISFYING CUSTOMER REQUIREMENTS.**

Today, Norton has a logistics team of 80 specialised people who are dedicated and focused on satisfying customer requirements. Our planning system, integrated directly with our order processing system, is managed and controlled by a team of forecasting experts who look to maintain and improve our service level (over 97% today).

Reviews are continuously undertaken to improve packaging techniques and new packaging technology is regularly considered, and implemented where appropriate. This ensures customers receive all products in excellent condition.

Norton operates the biggest abrasives distribution centre in Europe with 10 000m<sup>2</sup> used to stock more than 8000 product lines in one location. We have more products at our fingertips than any other abrasives manufacturer in the world. Shipping over 4000 product lines every day and working closely with carefully selected partners, gives us the necessary experience and expertise to provide an unrivalled delivery service to our customers.



CUTTING-OFF &amp; GRINDING WHEELS

COATED ABRASIVES &amp; BEARTEX

BONDED ABRASIVES

SUPER ABRASIVES

DIAMOND TOOLS

CLEANING, POLISHING &amp; MASKING

PERSONAL PROTECTION EQUIPMENT

TECHNICAL INFORMATION



## A HISTORY OF EXCELLENCE

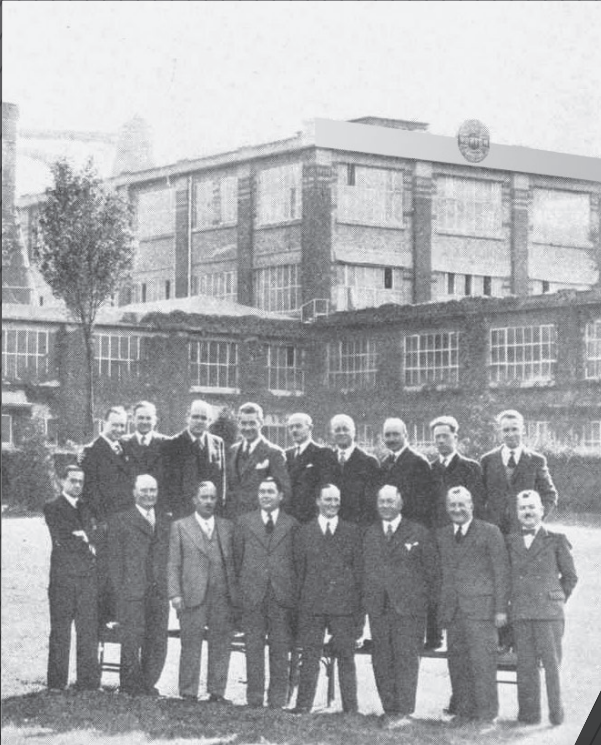

In the mid 19th Century, a group of ceramists and entrepreneurs in Worcester, Massachusetts, USA, set out with a goal: meet the growing need of the burgeoning U.S. manufacturing industry, which needed an ever increasing supply of grinding wheels to build and maintain machinery.

By 1876 Norton were manufacturing grinding wheels, and had acquired a patent for vitrified wheels. In 1885 the Norton Emery Wheel Co. was founded to manufacture the first grinding wheel that could be precision made and mass-produced.

Through the latter part of the 19th Century Norton expanded its abrasives range and reached customers throughout the U.S. and Canada. In 1909, Norton built its first European plant in Germany. This was followed by plants in France (1920), UK (1930), and Italy (1935). In the 1930's Norton strengthened its position by expanding into Coated Abrasives. In the same decade Norton developed Diamond and CBN based Super Abrasives.

By 1950 Norton had established itself as the leading world-wide abrasives brand. In 1956, Norton entered South America through an acquisition in Brazil, and followed this with plants in India (1968) and Japan (1972). This steady growth, based upon innovation, technology and responsiveness to customers, has continued and Norton now has a presence in 28 countries around the world.

In 1990, Norton was acquired by Saint-Gobain, a world leader in the manufacture of engineered materials. Saint-Gobain, founded in France in 1665, shares Norton's tradition of commitment to its business and customers, of understanding and responding to the needs of the marketplace and of technical innovation. Saint-Gobain's experience has been a strong addition to the Norton brand.

For over 125 years, Norton has provided innovative solutions for the challenges faced by industries. Our dedication to our business and customers ensures we will continue to be the world's number one abrasive manufacturer supplying a complete range of products that continually add value and efficiency to your operation.

**FOR OVER 125 YEARS, NORTON HAS PROVIDED INNOVATIVE SOLUTIONS FOR THE CHALLENGES FACED BY INDUSTRIES. OUR DEDICATION TO OUR BUSINESS AND CUSTOMERS ENSURES WE WILL CONTINUE TO BE THE WORLD'S NUMBER ONE ABRASIVE MANUFACTURER SUPPLYING A COMPLETE RANGE OF PRODUCTS THAT CONTINUALLY ADD VALUE AND EFFICIENCY TO YOUR OPERATION.**

# PATENTS & TRADEMARKS



Norton shows its commitment to innovation by filing Patents and Trademarks for its most innovative product solutions.

ALTOS®	NO-FIL®	RAPIDSTRIP™
BDX™	NORAX®	RED HEAT™
BEAR-TEX®	NORBIDE®	ROTOLO FOAM®
BLAZE®	NORCLEAN®	SG™
BLACK ICE™	NORFLEX™	SPEEDLOK™
BLUE FIRE®	NORLINE™	SPITFIRE™
DRY ICE™	NORTON QUANTUM™	STARLINE™
I-HD™	NORZON®	TOROS®
LIQUID ICE™	OCTOPUS®	VITRIUM <sup>3</sup> ®
MULTI-AIR®	PLASTIFILM®	VORTEX®
NEON™	PURE ICE™	VULCAN®

CUTTING-OFF  
& GRINDING  
WHEELSCOATED  
ABRASIVES  
& BEARTEXBONDED  
ABRASIVESSUPER  
ABRASIVESDIAMOND  
TOOLSCLEANING,  
POLISHING  
& MASKINGPERSONAL  
PROTECTION  
EQUIPMENTTECHNICAL  
INFORMATION





## CREATE GREAT LIVING PLACES AND IMPROVE DAILY LIFE

Saint-Gobain designs, manufactures and distributes materials and solutions which are key ingredients in the wellbeing of each of us and the future of all.

They can be found everywhere in our living places and our daily life: in buildings, transportation, infrastructure and in many industrial applications.

They provide comfort, performance and safety while addressing the challenges of sustainable construction, resource efficiency and climate change.

**SAINT-GOBAIN IS ONE OF THE WORLD'S TOP 100 LEADING INDUSTRIAL CORPORATIONS OPERATING IN 66 COUNTRIES WITH OVER 170,000 EMPLOYEES; IT IS RANKED AMONGST THE TOP 100 GLOBAL INNOVATORS AND HAS OVER 350 YEARS OF INDUSTRIAL HISTORY.**



### SAINT-GOBAIN IS THE LEADER IN MANY MARKETS

#### INNOVATIVE MATERIALS

##### FLAT GLASS

- No. 1 in Europe
- No. 2 worldwide

##### HIGH PERFORMANCE MATERIALS

- No. 1 worldwide

#### BUILDING DISTRIBUTION

- No. 1 building materials distributor in Europe
- Leading player on the plumbing-heating-sanitary market

#### CONSTRUCTION PRODUCTS

##### PIPELINES

- No. 1 worldwide in ductile cast iron pipe

##### GYPSUM

- No. 1 worldwide in plasterboard and plaster

##### INSULATION

- No. 1 worldwide in insulation

##### MORTARS

- No. 1 in Europe for wall facings
- No. 1 worldwide for tile adhesives

##### EXTERIOR PRODUCTS

- No. 2 in the United States for siding products

# DELIVERING A SUSTAINABLE FUTURE

In 2014 Saint-Gobain Abrasives launched its new sustainability plan aligned with our business values and vision. This 5 point plan of operational policies and practices underpins our commitment

to sustainable development as a global leader. We have made significant progress in advancing sustainability with a number of major accomplishments in each area which we have detailed below.

CUTTING-OFF & GRINDING WHEELS

COATED ABRASIVES & BEARTEX

BONDED ABRASIVES

SUPER ABRASIVES

DIAMOND TOOLS

CLEANING, POLISHING & MASKING

PERSONAL PROTECTION EQUIPMENT

TECHNICAL INFORMATION

## Our commitment to employees and sustainability

### Our Vision

Be the **global leader** of reference in Abrasives, at the leading edge of **innovation** and **service**. Delivering the most comprehensive **Abrasive Solutions** to our customers.



### Our Values

Comprehensively and strictly apply our Saint-Gobain Principles of Conduct & Action.

#### Conduct

- Professional commitment
- Respect for others
- Integrity
- Loyalty
- Solidarity

#### Action

- Respect for the law
- Caring for the environment
- Worker health and safety
- Employee rights



Pursue an ambitious policy to constantly **improve workplace health & safety**

In our Abrasives plants safety is our number one priority: lost time accidents have reduced five fold in 10 years

All operators individually assessed at least 3 times Per annum through the SMAT program (Senior Management Audit Tool) - >33,000 individual SMAT's conducted globally per annum

c.70,000 hours per annum of training worldwide on Saint-Gobain Safety Standards

Reduction of workplace hardship: exposure to noise, repetitive tasks, safety, ergonomics...

Reduction of exposure to chemicals

Annual world-wide EHS day







## 2. Continuously encourage the **personal development** of our employees

Saint-Gobain named as Top Employer 2015 for third consecutive year

Special focus on diversity, training and career management

Abra+ gives specific exposure of our young talents to senior management

60+ training courses proposed by Saint-Gobain Abrasives University and Saint-Gobain Training

Systematic employee satisfaction surveys



## 3. Be a **responsible & sustainable player** internationally & within our local communities

Founder member of FEPA and oSa, actively promoting the safety of abrasives

Sustainable development policies audited by VERITAS

Sponsors of local communities through initiatives such as social mobility, heating of local schools...

Extensive roll out of international standards ISO 9001, ISO 14001, OHSAS 18001

Internal testing & certification based on the following safety standards:

EN12413: 1999 ( Bonded Abrasives )    EN13236: 2001 ( Super Abrasives )  
EN13743: 2002 ( Coated Abrasives )    EN13236: 2001 ( Diamond Blades )

Saint-Gobain are endorsers of the Caring for Climate statement and the CEO Water Mandate for Water Resource Protection (as part of the UN's Millennium Development Goals)

Third party supplier charters, timber regulations, CSR evaluations and audits, Adhere process, minerals policy...

Saint-Gobain is a member of the United Nations Global Compact



## 4. Minimize the **environmental footprint** of our operations with five priorities

Increase the energy efficiency of our production

Increase the use of recycled raw materials in our plants

Reduce our CO<sub>2</sub> emissions

Optimize our water resources

Strict waste segregation policy



## 5. Continuously **develop eco-valorized products** bringing additional value to our customers

The first abrasives manufacturer to produce FSC® products

Use of natural resins and recycled grains

High performance abrasive products & solutions that help to reduce environmental impact and user exposure:

- low noise
- low vibration
- low dust



# ABRASIVE MARKETS

## METAL FABRICATION

Norton continues to play a key role in the Metal Fabrication market, delivering hi-tech relevant abrasive solutions for all applications in surface preparation and finishing. Decades of acquired expertise combined with innovative technology allows Norton to offer the most appropriate abrasive solutions for the most common applications, including: ship building, food industry, chemical and oil industries and boiler making.



APPLICATION	PRODUCT GROUP	MAIN BENEFITS	PAGE
Cutting sheet metal	Wheels for Angle Grinders	Fast cut operation	40
Heavy grinding & deburring	Fibre discs	Aggressive cutting	90
Welds grinding & blending	Flap discs	Versatility	94
Grinding & sanding all kind of metals	Narrow belts	High stock removal	240
Light to medium deburring	SpeedLok discs	Long life	121
Light to heavy duty cleaning	BearTex discs	High resistant	105
Finishing of Stainless Steel	Norax belts	Consistent and predictable surface finish	290
Cleaning & finishing	Flap wheels	Consistent finish	252
De-rusting of Steels, Inox	Wire Brushes	Steady Brushing	469

## NEW PRODUCTS

COATED ABRASIVES	PAGE	CUTTING-OFF & GRINDING WHEELS	PAGE
F975 GreenLyte Fibre discs	90	Norton Quantum	41
R828 X-Treme HD Flap discs			
F980 Norton Blaze			
R996 Viking belts	240		
R207 Flap wheels	252		



## THE ULTIMATE SOLUTION

An incomparably high performance, high quality product designed specifically for finishing.

**R946**



## GENERAL ENGINEERING

Norton provides technical solutions for applications from surface grinding to sharpening operations on a range of materials from high alloy to stainless steel. In addition Norton offers technical assistance to help provide optimum performance in application precision, quality of finishing and operation productivity. Typical sectors: mechanical, mould industry, tool industry, aerospace subcontractors and medical prosthesis.



APPLICATION	PRODUCT GROUP	MAIN BENEFITS	PAGE
Surface grinding	Vitrified wheels	Cool and burn-free cutting	326
Truing and dressing a wheel	Dressers	Optimises the cutting action and the finish	427
Restoring the cutting edge on tools	India stones	Long lasting cutting edge	374
Internal grinding	CBN wheels	Excellent cutting	404
Surface grinding and finishing	Narrow belts	Quick metal removal and surface finishing	240
Shaping and deburring	Carbide burrs	Long life, reduction of cutting force	484
Light deburring	Coated specialities	Conformability to complex surfaces	
Surface finishing	Flap wheels	Consistent wear rate, high quality results	252
Polishing of moulds	Beartex wheels	From preparatory lapping to finest finishing	105

## NEW PRODUCTS

BONDED ABRASIVES	PAGE	COATED ABRASIVES/BEARTEX	PAGE
Norton Quantum with Vitrium <sup>3</sup>	326	SpeedLok discs	121
Vortex Grinding wheels	329	Metal finishing convolute wheels	257

## THE ULTIMATE SOLUTION

Norton Quantum X grinding wheels are ideal for the most challenging applications including high material removal, heat sensitive and difficult to grind alloys and thin wall parts which may be sensitive to deformation.

## THE ULTIMATE GRINDING EXPERIENCE



## MAINTENANCE & REPAIR OPERATIONS

From the most advanced and critical operation to the simplest task, Norton provides an effective solution. Customers can benefit from the largest stock range of abrasives available anywhere in Europe. On any material Norton can provide you with a range of cost effective solutions for use by hand or machine.

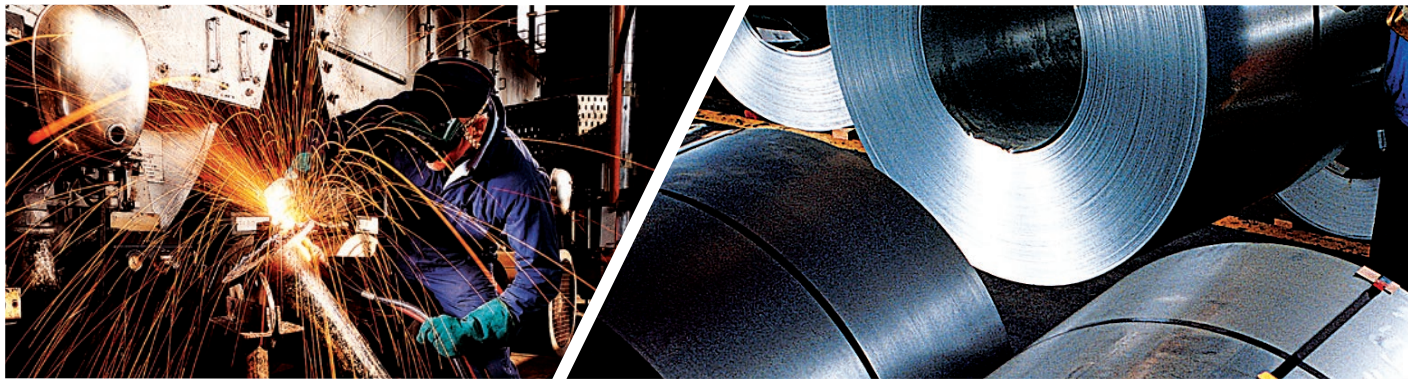

APPLICATION	PRODUCT GROUP	MAIN BENEFITS	PAGE
Sharpening HSS tools	Vitrified bench wheels	Free cutting	355
Light to heavy duty cleaning	Beartex sheets	Conformability to complex surfaces	214
Light deburring	Handy rolls	Long lasting cutting edge	224
Building maintenance	Portable diamond blades	Highly versatile product	442
Cutting pipe	Cut-off wheels	Fast cut	35
Weld & stock removal	Grinding wheels	Fast metal removal	
Blending welds	Flap discs	Versatile and long lasting	94
Deburring	Mounted points	Precise	366, 396
Removing imperfections	Specialities	Wide range of items for accessing intricate areas	

## NEW PRODUCTS

COATED ABRASIVES/BEARTEX	PAGE	DIAMOND BLADES BONDED ABRASIVES	PAGE
Flap Discs	94	4x4 Explorer	443
Convolute wheels	257	Starline bench wheels	356
Sanding Stars	161		

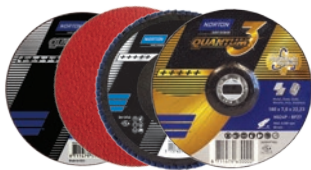

## THE ULTIMATE SOLUTION

The Norton Quantum platform of cutting-off, grinding wheels, flap discs and fibre discs offers the ultimate performance, unrivalled product life and highest material removal rates on stainless steels, alloys and carbon steels.

### THE NORTON QUANTUM PLATFORM

## WOODWORKING

Norton has actively developed new solutions with innovative abrasives products in full co-operation with customers over many years. Whatever the machine type is, Norton is in a position to optimise the sanding process. In addition to abrasives dedicated to sophisticated machines, Norton has created a very effective range of tools, easy to use like sponges or sanding block for manual operations. Furthermore, a huge variety of product shapes are available to fit with any particular application that requires specific abrasive types. Typical sectors: carpentry, furniture manufacturer, parquetry (manufacturer and renovation), boat and marine.



APPLICATION	PRODUCT GROUP	MAIN BENEFITS	PAGE
Sanding & finishing of wood	Narrow and wide belts	Long life	271
Sanding contours	Abrasives sanding sponges	Soft and versatile manual finishing	216
Sanding contours	Narrow belts	Very flexible for machine polishing	248
Re-sharpening saw blade	Vitrified wheel	No burn and straight cut	350
Sanding	Portable belts	Long life	236
Hand sanding	Paper sheets	Load resistant	200
Bare wood sanding	Cloth rolls	Excellent finish	222
Varnished surface sanding	No-Fil paper discs	Anti-clogging and longer lasting	171
Edges sanding	Polyester narrow belts	Sharp and long lasting belts	248

## NEW PRODUCTS

COATED ABRASIVES/BEARTEX	PAGE
Norton Ice Discs	181
Multi-Air Discs	174

## THE ULTIMATE SOLUTION



These high performance aluminium oxide belts are ideal for any sanding applications, from rough sanding to finishing operations.

### H231 & H235 NARROW & WIDE BELTS



## FLOOR SANDING

Norton leads the development of abrasive technology in this market through innovations such as Norton Red Heat R955 with SG grain which provides the optimum productivity at the lowest cost.

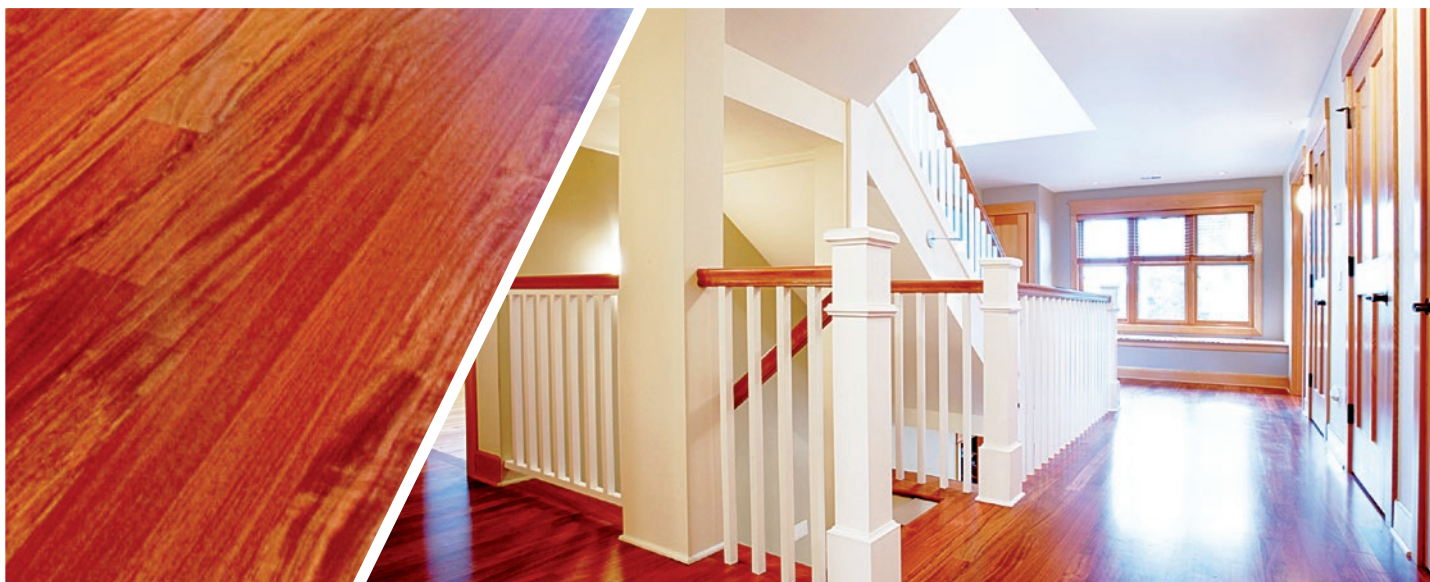

APPLICATION	PRODUCT GROUP	MAIN BENEFITS	PAGE
Drum sanders	Sheets and rolls	Easy to use, load resistant	277
Belt sanders	Belts	Ideal cost/benefit ratio	274
Edger sanders	Discs	Time-saving	280
Buffer sanders	Screenback Double-sided discs	Anti-clogging for a perfect finish	279

## NEW PRODUCTS

COATED ABRASIVES/BEARTEX	PAGE
Red Heat R955 belts	274

## THE ULTIMATE SOLUTION



These polyester backed belts are extremely strong and ideal for floor sanding. There's no need to look for any other product when sanding hard wood.

### RED HEAT R955 BELTS

## FOUNDRY

Norton holds significant expertise in the foundry applications by conducting thorough analysis of the complete abrasive process to help maximize productivity. The products offered are capable of providing incomparable solutions for the most demanding applications in the industry. Typical sectors: aerospace, automotive and medical prosthesis.



APPLICATION	PRODUCT GROUP	MAIN BENEFITS	PAGE
Deburring	Grinding wheels	High stock removal rate	51
Removing cracks	Resin bond wheel	Fast operation	393
Shaping and deburring	Carbide burrs	Fast cutting	484
Gate removal	Supersize Narrow belts	Cool cut for heat sensitive metal	240
Gate removal	Resin mounted wheels	High stock removal rate	396
Cutting-off	Large Cut-off wheels	Free cutting	385

## NEW PRODUCTS

COATED ABRASIVES	PAGE	BONDED ABRASIVES	PAGE
R996 Viking belts	240	Reinforced organic cut-off wheel	388
Tungsten carbide burrs	484		

## THE ULTIMATE SOLUTION



Norton Foundry X cut-off and grinding wheels have been specifically designed for heavy duty foundry applications and to perform on a range of tough materials.

**FOR FOUNDRY APPLICATIONS**



## RAIL

Rail track is continuously subjected to high stress as a result of the millions of tons of train riding over them each year. Norton makes significant investment in the research and development of all abrasive applications encountered in the rail industry ensuring it continues to offer the most suitable range of abrasive products that focus on providing effective, accurate and safe results. Norton's products for the rail industry are each specifically designed to take into account the hardness of the metal used and the unique shape of rail track.



APPLICATION	PRODUCT GROUP	MAIN BENEFITS	PAGE
Cutting rail	Cut-off wheels	White and straight cuts	65
Deburring rails	Grinding wheels	Weld preparation	40
Grinding rails	Organic cup wheel	Excellent preparation of the rail before welding	393
Finishing welds	Organic straight wheel	Fast operation	393
Deburring Welds	Carbide Burrs	Faster removal than mounted points	484

## NEW PRODUCTS

COATED ABRASIVES	PAGE	BONDED ABRASIVES	PAGE
R996 Viking belts	240	Reinforced organic cut-off wheel	388
Tungsten carbide burrs	484		

## THE ULTIMATE SOLUTION



A comprehensive portfolio of high end rail cutting wheels including the fast cutting A24P-BF41, the long life ZA24T-BF41 and the latest ZA24Q which offers both a fast precise cut and long life.

**PRECISION, SPEED AND POWER**



## TOOL ROOM

The maintenance and repair of cutting tools is common place in almost every manufacturing plant. Norton has a range of highly effective solutions suitable for tool room cutting and sharpening operations.



APPLICATION	PRODUCT GROUP	MAIN BENEFITS	PAGE
Sharpening cemented carbide cutting tools	Diamond wheels	High removal rate could be used wet or dry	399
Cutting drill bits	Non-Reinforced Cut-off wheels	Produce minimal burr and burn	390
Sharpening HSS cutting tools	CBN wheels	Free cutting	399
Sharpening tools	Vitrified cups and dishes	High removal rate and extended product life	301

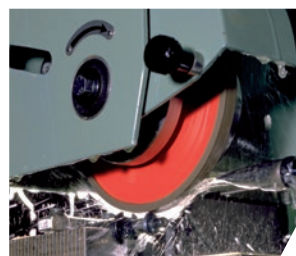

## THE ULTIMATE SOLUTION

The state-of-the-art Norton B99 bond has been developed for almost all applications, covering the grinding of round tools, saw blades, knives, milling cutters, as well as all OD, flat, and ID applications.

### NORTON B99

## GLASS

Norton offers innovative technological solutions with coated and non-woven abrasives, and supplies a full range of products to cover the various needs for glass converting and finishing operations. Norton has been successful in adapting and evolving its products to match customer's processes in order to meet the most stringent surface quality standards on any type of machine designed for the Glass market. Typical sectors: safety and special glass, building and furniture glass.



APPLICATION	PRODUCT GROUP	MAIN BENEFITS	PAGE
Edge grinding	Narrow belts	High resistant and long life	289
Edge grinding	Cross belts	High quality and resistant	289
Edge finishing	Cork belts	High finishing quality	290
Removal coating after cutting	Beartex wheels	High performance	257

## THE ULTIMATE SOLUTION



Norax belts provide an unparalleled surface finish on all glass applications. The grit X5 is ideal for final finishing of glass edges. Made to order.

[U366 Norax Narrow Belts](#)



## OIL & GAS

Norton has developed a complete range of abrasives specifically designed for the manufacture and repair of upstream, midstream and downstream components, shipbuilding, oil rigs, pipelines, and petrochemical plants. As well as an extensive variety of abrasives for rough and precision grinding, finishing and polishing, Norton offers new innovations, on-site technical support and bespoke solutions for the engineering challenges faced in the industry.



APPLICATION	PRODUCT GROUP	MAIN BENEFITS	PAGE
OD grinding, plungers	Bonded grinding wheels	Excellent part quality and cost reduction	301
ID manual grinding, stabilizer/reamers	Flap discs	Weld preparation & removal	96
Cylindrical grinding rods	Narrow belts for metal	Excellent surface finish	241
Polishing rotors/stators	Non-woven discs	Eliminates process stages, saving time & money	128, 134
Portable off-hand, pipe and weld preparing	Cutting-off and grinding wheels	High stock removal on all materials	48

## NEW PRODUCTS

CUTTING-OFF & GRINDING WHEELS	PAGE	COATED ABRASIVES	PAGE
Oil & Gas	48	Oil & Gas flap discs	96



## THE ULTIMATE SOLUTION

Norton Quantum3 grinding wheels provide the ultimate performance in all demanding applications even on hard alloy steels, providing unrivalled life, highest metal removal rates and the fastest cutting action.



## MERCHANDISING SOLUTIONS

We have a complete set of Norton branded displays to help showcase our products in all environments, plus off the shelf point-of-sale graphics that can also be tailored to customer requirements whether that's for cutting-off and grinding, stock removal, or surface preparation and finishing.



### NORTON DISPLAY KIT

- The complete kit comes with all components needed to create a full display for any product range.
- Kit contains:  
Base x1, pegboards x4, header x1, shelf x1, display bar with 5 pins x1, legs x2, pegs x35
- Accessories can be ordered separately if required.

KIT DESCRIPTION	PK QTY	ART NO.
Complete kit with light	1	410076979
Complete kit with light & UK plug	1	410058121
Complete kit without light	1	410076980

### PORTABLE DISPLAY FOR CUTTING-OFF & GRINDING WHEELS

- Kit contains:  
Unit x1, header x1, pins x22, side panels x2
- H: 1740mm x W: 380mm x D: 580mm

DESCRIPTION	PK QTY	ART NO.
Portable cutting-off & grinding stand	1	410090016





**NORTON**

SAINT-GOBAIN



**www**

**NOW LIVE!**

Announcing the launch of our new global website [www.nortonabrasives.com](http://www.nortonabrasives.com), marking a new day in the online world of Norton Abrasives!

The new Norton site delivers a deeper brand experience by giving users detailed access to products, markets, machines and surfaces. It gives more focus on product selection and key sub-brands, with a cleaner layout and dynamic lifestyle photography, and thanks to a more intuitive navigation and responsive design, the new site is easier to navigate on any mobile device.

Going live is only the start of our journey... we will continually enrich the site with fresh content and new features so that your online experience continues to be as good as it can be.

**EXPLORE...**

**[www.nortonabrasives.com](http://www.nortonabrasives.com)**

INTRODUCTION

CUTTING-OFF  
& GRINDING  
WHEELS

COATED  
ABRASIVES  
& BEARTEX

BONDED  
ABRASIVES

SUPER  
ABRASIVES

DIAMOND  
TOOLS

CLEANING,  
POLISHING  
& MASKING

PERSONAL  
PROTECTION  
EQUIPMENT

TECHNICAL  
INFORMATION



# HOW TO USE THIS CATALOGUE

The Norton product line is segmented into easy-to-use, colour-coded sections. Each of these sections are divided into sub-sections which are categorised by product type, machine type or application.

The first part of each sub-section is designed to help you find the right product – each product is categorised by Good, Better, Best, and is supported by key features and benefits, applications and markets and selection tables.

The second part of each sub-section comprises of product tables – designed to give quick and easy product reference details.

The tables are arranged by product type or application (for Diamond Blades and Cutting Off and Grinding Wheels). The Good, Better, Best concept is repeated to bring clear product comparison. Dimensions, grit, pack quantity and product codes are clearly displayed. In addition, Product Selection charts serve as a quick reference guide to the range. 'Spec Checks' also give helpful information on specific products or range benefits.

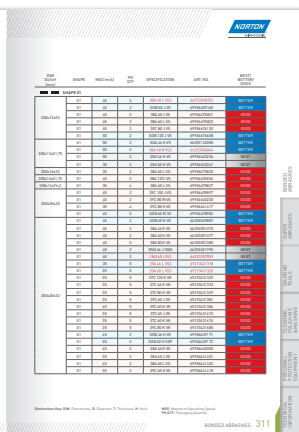
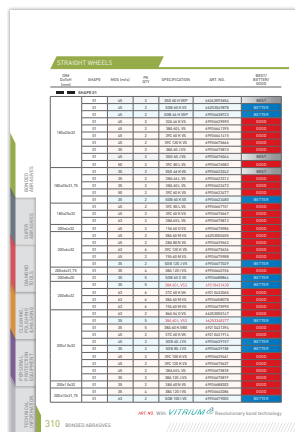
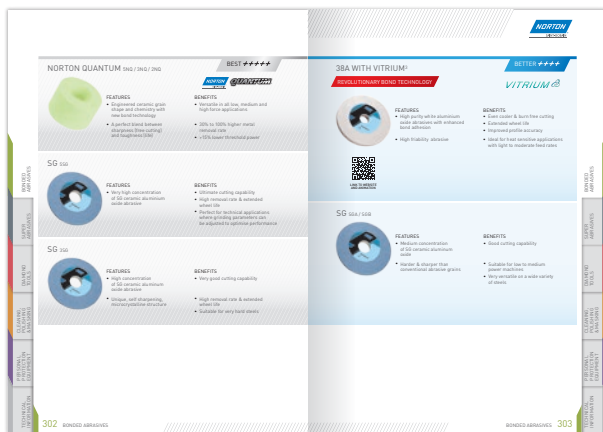

Technical and Safety information for each of the core product types is included in a separate section at the back of the catalogue.

## HOW TO ORDER

Please contact your local Customer Service Centre, details can be found on the back page of the catalogue. For countries that are not listed please send your request to our European Headquarters.



When placing an order it helps to have the following information available:

- Your name
- Your account number
- Your order or reference number
- Product article number/s
- Required quantity
- Any special instructions

If you require additional product or technical information then please do not hesitate to contact your local Customer Service or Sales Representative.

For prices and terms of sale please refer to the price list.

### E-PARTNER

We offer two forms of electronic ordering; online ordering through Abrasive Connection or through a full EDI ordering facility. If you are interested in either please contact Customer Service.





# 35-70 CUTTING-OFF & GRINDING WHEELS



CUTTING-OFF  
& GRINDING  
WHEELS

COATED  
ABRASIVES  
& BEARTEX

BONDED  
ABRASIVES

SUPER  
ABRASIVES

DIAMOND  
TOOLS

CLEANING,  
POLISHING  
& MASKING

PERSONAL  
PROTECTION  
EQUIPMENT

TECHNICAL  
INFORMATION

36 Introduction

40 Wheels for Angle Grinders

63 Wheels for Petrol Saws

64 Wheels for Chop Saws

65 Wheels for Rail

67 Wheels for Stationary  
Machines

# INTRODUCTION

The Norton range of Cutting-off and Grinding Wheels for portable and fixed machines provide superior performance in the most stringent working environment. The product range includes state-of-the-art solutions for Cutting-off, Grinding, and Surface Finishing operations on any materials related to industrial fabrication markets. Norton, the industry's most comprehensive Cutting-off and Grinding product line.

CUTTING-OFF & GRINDING WHEELS

COATED ABRASIVES & BEARTEX

BONDED ABRASIVES

SUPER ABRASIVES

DIAMOND TOOLS

CLEANING, POLISHING & MASKING

PERSONAL PROTECTION EQUIPMENT

TECHNICAL INFORMATION

## UNDERSTANDING THE PRODUCT

- 1 Best quality tier
- 2 Application material
- 3 Diameter x Thickness x Hole
- 4 Product specification
- 5 Maximum peripheral speed
- 6 Machine cutting or grinding
- 7 Product code
- 8 OSA certification
- 9 European standard



## SHAPE SPECIFICATION SYSTEM

All Norton products are designed to be operator friendly with high safety standards to satisfy the requirements of all professional users.

For further information please go to the Technical Information Section at the back of this catalogue.

BF 27	BF 29	BF 41	BF 42
DEPRESSED CENTRE GRINDING WHEELS	DEPRESSED CENTRE GRINDING WHEELS	FLAT CUTTING-OFF WHEELS	DEPRESSED CENTRE CUTTING-OFF WHEELS
Available in diameters 76-230mm for hand-held machines.	Available in diameters 115mm and 125mm for hand-held machines.	Available in diameters 50-400mm for hand-held machines and 250-400mm for stationery machines.	Available in diameters 76-230mm for hand-held machines.
Application: Grinding	Application: Grinding	Application: Cutting-off	Application: Cutting-off

## DIFFERENTIATION IN THE RANGE

Norton offers the industry's widest selection of cutting-off and grinding wheels designed to meet every customer's requirement. The range is classified into 3 tiers (Best/ Better/ Good) to help you choose the right product for your specific application.

**BEST +++++  
INNOVATION**

With unparalleled abrasive technology, Norton Quantum 3 and Norton Quantum provides optimum solutions with innovative products dedicated to industrial applications. Norton Quantum 3 wheels deliver an extremely comfortable and efficient grinding solution for all demanding metal fabrication applications. They maintain a consistently high stock removal, even on hard alloy steels, maximizing product throughput without the need for high pressure.

**BEST +++++**





Norton offers premium quality product ranges of aluminium oxide (Omega) abrasive Cutting-off & grinding wheels. These ranges have been developed to meet the demands of the most discerning users. Norton Omega ensures outstanding cutting speed and stock removal rates combined with exceptional long life meaning lower abrasive costs.

**BETTER +++++**

Norton Vulcan and Norzon cutting-off and grinding wheels are extensively used across a range of industries including aerospace, automotive, foundry, fabrication, ship-building and construction. Norton Vulcan and Norzon set an industrial performance standard amongst conventional aluminum oxide grain technologies. They provide optimum performance to price ratio throughout all steel, stainless steel, aluminum and stone applications.

**GOOD +++**

Norton Starline gives above average performance for cutting-off and grinding operations on a wide range of materials, including steel, stainless steel, cast iron and stone.

	BEST INNOVATION	BEST	BETTER	GOOD
 METAL	NORTON QUANTUM 3, NORTON QUANTUM	1-2-3, OMEGA, BLUE FIRE	OIL & GAS, VULCAN	STARLINE
 INOX	NORTON QUANTUM 3, NORTON QUANTUM	1-2-3, OMEGA, BLUE FIRE	OIL & GAS, VULCAN	
 METAL INOX	ACCU, NORTON QUANTUM 3, NORTON QUANTUM	1-2-3, OMEGA, BLUE FIRE	OIL & GAS, NORZON, VULCAN, OCTOPUS	STARLINE
 ALU, METAL, INOX, STONE, C TILES, PVC	ACCU		MULTI-PURPOSE	
 ALU			NORLINE	
 STONE			VULCAN	STARLINE
 STONE TILES			MULTI-PURPOSE	
 RAIL/METAL			RAIL	
 CAST IRON METAL INOX	NORTON QUANTUM		NORZON, FOUNDRY X	
 CAST IRON METAL	NORTON QUANTUM		VULCAN, NORZON	



# INTRODUCTION



CUTTING-OFF  
& GRINDING  
WHEELS

COATED  
ABRASIVES  
& BEARTEX

BONDED  
ABRASIVES

SUPER  
ABRASIVES

DIAMOND  
TOOLS

CLEANING,  
POLISHING  
& MASKING

PERSONAL  
PROTECTION  
EQUIPMENT

TECHNICAL  
INFORMATION

## PRODUCT SELECTION - CUTTING-OFF WHEELS FOR ANGLE AND STRAIGHT GRINDERS

Usage Key	ACCU	NORTON QUANTUM ULTIMATE TECHNOLOGY	OMEGA	1-2-3 THE ALL IN ONE SOLUTION	BLUE FIRE	OIL & GAS	NORZON QUICK CUT	NORZON FOUNDRY	MULTI-PURPOSE	NORTON ALU	VULCAN (Metal-Inox)	VULCAN (Inox)	RAIL	VULCAN (Stone)	STARLINE (Metal-Inox)	STARLINE (Stone)
	BEST		BEST			BETTER							GOOD			
	INNOVATION															
Steel, construction steel	●	●	●	●	●	●	●	●	●	○	●	○			●	
Low-alloy steel	●	●	●	●	●	●	●	●	●	○	●	○			●	
High-alloy steel	●	●	●	●	○	○	●	●	●	○	○	●			○	
Thin sheets, plates profiles	●	●	●	●	●	○	●	●	●	●	●	●			●	
Stainless steel, Inox	●	●	●	●	●	○	●	●	●	○	●	●			○	
Cast iron		●	●			●	○	●						○		○
Non-ferrous									●	●			●	○		○
Titanium									●	●			●	●		●
Stone, concrete	●								●					●		●
Tiles, ceramic	●								●							
Glass, plastic, pvc	●								●							



## PRODUCT SELECTION - GRINDING WHEELS FOR ANGLE GRINDERS

Usage Key ● Highly recommended ○ Recommended	ACCU	NORTON QUANTUM 3	OMEGA	1-2-3 THE ALL IN ONE SOLUTION	BLUE FIRE	OIL & GAS	NORZON QUICK CUT	NORZON FOUNDRY	FOUNDRY X	OCTOPIUS	NORTON ALU	VULCAN WITH NORZON TECHNOLOGY	VULCAN (Metal-Inox)	VULCAN FAST CUT (Metal-Inox)	VULCAN (Inox)	RAIL	VULCAN (Stone)	STARLINE (Metal-Inox)	STARLINE (Stone)
	BEST		BEST			BETTER											GOOD		
	INNOVATION 3																		
Steel, construction steel	●	●	●	●	●	●	●	●	●	●	○	●	●	●	○	●		●	
Low-alloy steel	●	●	●	●	●	●	●	●	○	●	○	●	●	●	○	○		●	
High-alloy steel	●	●	○	●	○	○	●	●	●	●	○	●	○	○	●	○		●	
Stainless steel, Inox	●	●	○	●	○	○	●	●		●	○		○	○	●			○	
Cast iron		●	●			●	○	●	●		○	●		○			○		○
Non-ferrous	○										●								
Titanium											●						●		●
Stone, concrete	●																●		●



# WHEELS FOR ANGLE GRINDERS

NORTON offers the widest range of wheels for cutting and grinding designed to meet all requirements of industrial customers.

## APPLICATIONS & MARKETS

- Aerospace
- Automotive
- Construction
- Fabrication
- Foundry
- Rail industry
- Ship-building



CUTTING-OFF & GRINDING WHEELS

COATED ABRASIVES & BEARTEX

BONDED ABRASIVES

SUPER ABRASIVES

DIAMOND TOOLS

CLEANING, POLISHING & MASKING

PERSONAL PROTECTION EQUIPMENT

TECHNICAL INFORMATION

## ACCU

BEST +++++

INNOVATION

Norton Accu cutting-off & grinding wheels have been developed to give minimal resistance when in use and its free cutting feature absorbs less energy from the battery. It also features a special bond and grain which gives improved user comfort and longer wheel life.

### FEATURES

- Quick, straight cuts with 1,0 thickness
- Cutting, light grinding and polishing with Accu 1-2-3
- Aggressive grain leads to less energy absorption from the battery
- Optimized for cordless grinders
- Optimized for machines of 900W or less

### BENEFITS

- Maximum performance with minimum power
- Enable to work in difficult working areas like work at heights
- Low vibration and comfortable work
- No contamination of stainless steel
- Maximum safety



TYPE	DIA (mm)	TxB (mm)	SPECIFICATION	PK QTY	ART NO.
41	115	1,0x22,23	A 60 R	5	66252843020
	125	1,0x22,23	A 60 R	5	66252843019

Delivery unit 20 sets



TYPE	DIA (mm)	TxB (mm)	SPECIFICATION	PK QTY	ART NO.
27	115	2,2x22,23	C46P	2	66252843018
	125	2,2x22,23	C46P	2	66252842832

Delivery unit 20 sets



# NORTON QUANTUM ULTIMATE TECHNOLOGY



Norton Quantum ultra thin cut-off wheels for stainless, alloy and carbon steels provide unrivalled wheel life, highest metal removal rates and fastest cutting action.

### FEATURES

- Premium aggressive NorZon Heavy Duty grain
- Revolutionary Patent Pending Bond Technology

### BENEFITS

- No other wheel lasts longer
- Lowest total abrasive costs
- High metal removal rate
- Fast cutting
- High stability & low vibration
- Less material loss
- Less noise & dust
- Less energy consumption
- Burr-free cutting
- White and clean cutting
- Extreme precision and straight cutting



VIDEO LINK

TYPE	DIA (mm)	TxB (mm)	SPECIFICATION	PK QTY	ART NO.
41	115	1,0x22,23	ZA 60 ZZ	25	66252836338
		1,3x22,23	ZA 60 ZZ	25	66252836897
		1,6x22,23	ZA 46 ZZ	25	66252836339
	125	1,0x22,23	ZA 60 ZZ	25	66252836340
		1,3x22,23	ZA 60 ZZ	25	66252836898
		1,6x22,23	ZA 46 ZZ	25	66252836341
		2,0x22,23	ZA 46 ZZ	25	66252843896
	180	1,6x22,23	ZA 46 ZZ	25	66252837989
230		1,9x22,23	ZA 46 ZZ	25	66252837990
42	115	0,8x22,23	ZA 60 ZZ	25	66252840228
	125	0,8x22,23	ZA 60 ZZ	25	66252838243

**Dimensions Key:** DIA = Diameter, T = Thickness, B = Bore

CUTTING-OFF & GRINDING WHEELS

COATED ABRASIVES & BEARTEX

BONDED ABRASIVES

SUPER ABRASIVES

DIAMOND TOOLS

CLEANING, POLISHING & MASKING

PERSONAL PROTECTION EQUIPMENT

TECHNICAL INFORMATION

## NORTON QUANTUM 3

Norton Quantum 3 Grinding Wheels are **MADE TO BITE**

Norton Quantum 3 grinding wheels have been specifically developed by Saint-Gobain Abrasive's R&D team to address the needs of the construction and welding industries for more aggressive, faster and more comfortable grinding wheels. Made from proprietary ceramic grain technology and a newly engineered bond system enabling higher grain retention for longer life and a reduction in grinding temperature Norton Quantum 3 provides three key benefits for the end user:

1. Better operator comfort with reduced hand fatigue from less cutting vibration.
2. Less grinding time, a sharper wheel for high metal removal and reduced pressure from faster cutting action.
3. Less downtime and waste with longer wheel life using fewer wheels.

These benefits are key for weld removal, cleaning, bevelling and general grinding applications on black steel, duplex, high chrome alloys and hard alloys in the maintenance and repair, gas & off-shore, shipbuilding, metal fabrication and steel construction industries where Norton Quantum 3 can help to reduce overall process time and cost.

METAL  
INOXY

TYPE 27



TYPE	DIA (mm)	TxB (mm)	SPECIFICATION	PK QTY	ART NO.
27	115	7,0x22,23	NQ 24 P	10	66253371361
	125	7,0x22,23	NQ 24 P	10	66253371362
	150	7,0x22,23	NQ 24 P	10	66253371363
	180	7,0x22,23	NQ 24 P	10	66253371364
	230	7,0x22,23	NQ 24 P	10	66253371365

METAL  
INOXY

TYPE 27



TYPE	DIA (mm)	TxB (mm)	SPECIFICATION	PK QTY	ART NO.
27	115	4,2x22,23	NQ 24 R	20	66253371356
	125	4,2x22,23	NQ 24 R	20	66253371357
	150	4,2x22,23	NQ 24 R	20	66253371358
	180	4,2x22,23	NQ 24 R	20	66253371359
	230	4,2x22,23	NQ 24 R	20	66253371360

# OMEGA

BEST +++++

Norton Omega cutting-off and grinding wheels work faster and last longer than standard products, saving you time, money and increasing productivity. Premium, sharp aluminium oxide grain and superior bond system provide exceptional performance in even in the most demanding cutting and grinding applications on metal.

### FEATURES

- Premium, sharp aluminium oxide grain
- Superior bond system
- Iron, sulphur and chlorine free

### BENEFITS

- High material removal rates
- Higher G ratio than standard products
- Faster cutting action
- Longer lasting than standard products
- No contamination transferred to the work piece



TYPE	DIA (mm)	TxB (mm)	SPECIFICATION	PK QTY	ART NO.
41	115	1,0x22,23	A 60 W	25	66253370025*
		1,6x22,23	A 46 W	25	66253370026*
	125	1,0x22,23	A 60 W	25	66253370029*
		1,6x22,23	A 46 W	25	66253370030*
	150	1,6x22,23	A 46 W	25	66253370033**
	180	1,6x22,23	A 46 W	25	66253370034**
230	1,9x22,23	A 36 W	25	66253370036**	

\* +30% performance upgrade

\*\* +30% performance upgrade. These wheels will be available from mid of 2017

**Dimensions Key:** DIA = Diameter, T = Thickness, B = Bore

CUTTING-OFF & GRINDING WHEELS

COATED ABRASIVES & BEARTEX

BONDED ABRASIVES

SUPER ABRASIVES

DIAMOND TOOLS

CLEANING, POLISHING & MASKING

PERSONAL PROTECTION EQUIPMENT

TECHNICAL INFORMATION





TYPE 41

TYPE 42



TYPE	DIA (mm)	TxB (mm)	SPECIFICATION	PK QTY	ART NO.
41	115	2,0x22,23	A 36 W	25	66253370027
		2,5x22,23	A 36 W	25	66253370028
	125	2,0x22,23	A 36 W	25	66253370031
		2,5x22,23	A 36 W	25	66253370032
	180	2,0x22,23	A 36 W	25	66253370035
	230	2,0x22,23	A 36 W	25	66253370037
2,5x22,23		A 36 W	25	66253370039	
42	115	2,5x22,23	A 36 W	25	66253370040
	125	2,5x22,23	A 36 W	25	66253370041
	180	2,5x22,23	A 36 W	25	66253370043
	230	2,5x22,23	A 36 W	25	66253370044



TYPE 27



TYPE	DIA (mm)	TxB (mm)	SPECIFICATION	PK QTY	ART NO.
27	115	7,0x22,23	A 24 S	10	66253370045
	125	7,0x22,23	A 24 S	10	66253370046
	150	7,0x22,23	A 24 S	10	66253370047
	180	7,0x22,23	A 24 S	10	66253370048
	230	7,0x22,23	A 24 S	10	66253370050



TYPE 27



TYPE	DIA (mm)	TxB (mm)	SPECIFICATION	PK QTY	ART NO.
27	125	4,0x22,23	A 24 S	10	66253370042

## 1-2-3 THE ALL IN ONE SOLUTION



Safe cutting, grinding and polishing with a single product.

### FEATURES

- Cutting, light grinding & polishing with one single product
- Fine grit
- Low vibration
- Three layered strong reinforcement
- Free of iron, sulphur & chlorine

### BENEFITS

- No more lost time due to machine or product changing
- Excellent & uniform finishing result
- Comfortable working
- Operator friendly
- Maximum safety
- No contamination



VIDEO LINK

TYPE	DIA (mm)	TxB (mm)	SPECIFICATION	PK QTY	ART NO.
27	115	2,2x22,23	A 46 S	25	66252829704
	125	2,2x22,23	A 46 S	25	66252921592

**Dimensions Key:** DIA = Diameter, T = Thickness, B = Bore

CUTTING-OFF & GRINDING WHEELS

COATED ABRASIVES & BEARTEX

BONDED ABRASIVES

SUPER ABRASIVES

DIAMOND TOOLS

CLEANING, POLISHING & MASKING

PERSONAL PROTECTION EQUIPMENT

TECHNICAL INFORMATION

## BLUE FIRE

The Norton Blue Fire range of cutting-off and grinding wheels offers a choice of high quality metal working tools for all rough applications including: weld removal, surface preparation, metal removal, reshaping and cutting-off rusted and corroded materials. Norton Blue Fire is the choice of the professional and brings quick and comfortable results. The range is packed in small quantity packs that are re-closable.

### FEATURES

- High performance grains
- Newly developed high performance abrasive grain in combination with strong bond system
- Wide range of products

### BENEFITS

- Long life and comfortable working
- 50% + more cuts. Longer life, easier cutting and quicker working with minimum blueing, deburring or reworking
- Products for straight grinders as well as angle grinders in high performance quality level



TYPE 41

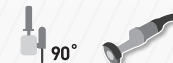

TYPE	DIA (mm)	TxB (mm)	SPECIFICATION	PK QTY	ART NO.
41	50	1,0x6,35	A 60 T	50	66252842745**
		2,0x6,35	A 60 T	50	66252842746
	63	1,0x10	A 60 T	50	66252828195**
		2,0x6,35	A 60 T	25	66252828239
	76	1,0x6,35	A 60 T	50	66252828240**
		1,0x10	A 60 T	50	66252844850**
		1,6x10	A 60 T	50	66252828242**
		2,0x6,35	A 60 T	25	66252828243
		2,0x8,0	A 60 T	25	66252828244
		2,0x10	A 60 T	25	66252828245
	100	1,0x10	A 60 T	50	66252828246
		1,0x16	A 60 T	50	66252828247**

\*\* +50% performance upgrade



TYPE 41



TYPE	DIA (mm)	TxB (mm)	SPECIFICATION	PK QTY	ART NO.
41	115	1,0x22,23	A 60 T	25	66252828255
		1,0x22,23	A 60 T	25	66252828256
	125	1,6x22,23	A 60 T	25	66252828257





TYPE	DIA (mm)	TxB (mm)	SPECIFICATION	PK QTY	ART NO.
41	115	1,0x22,23	C 60 T	25	66252828253
	125	1,0x22,23	C 60 T	25	66252828254



TYPE	DIA (mm)	TxB (mm)	SPECIFICATION	PK QTY	ART NO.
41	50	6,0x6,35	A 24 R	10	66252828248
	63	6,0x10	A 24 R	10	66252828249
	76	7,0x10	A 24 R	10	66252828250



TYPE	DIA (mm)	TxB (mm)	SPECIFICATION	PK QTY	ART NO.
27	115	7,0x22,23	A 24 R	10	66252828251
	125	7,0x22,23	A 24 R	10	66252828252

Dimensions Key: DIA = Diameter, T = Thickness, B = Bore



**SPEC CHECK**

Thin wheels for use on drills, straight grinders, machines with flexible shaft and low revolutions pneumatic machines have to be used in combination with corresponding spindles.

SAP number	Description	Size
07660739614	Spindle for straight grinder	6mm
07660739615	Spindle for straight grinder	10mm
07660739616	Spindle for straight grinder	8mm

## OIL &amp; GAS

BETTER ++++



For the highest standards in safety and performance, the Norton Oil & Gas range is the perfect solution, offering high material removal, low vibration and maximum working comfort.

## FEATURES

- High performance durable grain
- Advanced bond system
- Heavy glass fiber reinforcement
- Highest metal removal on high alloys and special steels

## BENEFITS

- Longer product life even in extreme, high pressure applications
- Improved user comfort
- Supreme safety levels for use in the toughest conditions
- Specially selected product range for applications found in the Oil and Gas market

TYPE	DIA (mm)	TxB (mm)	SPECIFICATION	PK QTY	ART NO.
27	115	7,0x22,23	A 24 Q	25	66252844788*
	125	7,0x22,23	A 24 Q	25	66252844789
	180	7,0x22,23	A 24 Q	25	66252844790
	230	7,0x22,23	A 24 Q	25	66252844791
41	115	1,0x22,23	A 60 T	25	66252844792
		1,6x22,23	A 46 T	25	66252844793*
	125	1,0x22,23	A 60 T	25	66252844794
		1,6x22,23	A 46 T	25	66252844795
		2,5x22,23	A 46 T	25	66252844910
	180	1,6x22,23	A 46 T	25	66252844796
		2,5x22,23	A 46 T	25	66252844911
	230	1,9x22,23	A 36 T	25	66252844797
2,5x22,23		A 36 T	25	66252844912	
27	125	4,0x22,23	A 24 T	25	66252844815
	180	4,0x22,23	A 24 T	25	66252844835
	230	4,0x22,23	A 24 T	25	66252844836*



VIDEO LINK

\* Made-to-order

## NORZON QUICK CUT

NorZon Quick Cut cutting and grinding wheels provide optimal performance on stainless steel and all hardened steel alloys. They are also suitable for cast iron applications. NorZon Quick Cut products deliver high value and high performance industrial solutions.

### FEATURES

- Premium combination of zirconia grain and advanced bond system
- Suitable for stainless steel, hardened steel and cast iron applications
- Q-Soft
- R-Medium
- S-Hard
- Free of iron, sulphur & chlorine

### BENEFITS

- Superior performance compared to standard aluminum oxide wheels
- Highest productivity means lowest operating cost
- Easy & comfortable grinding
- Optimised for thick applications
- High stability for easy & comfortable cutting
- Fast material removal
- Optimised for universal applications
- Long product life
- No contamination



TYPE	DIA (mm)	TxB (mm)	SPECIFICATION	PK QTY	ART NO.
27	100	4,6x16,0	ZA 24 S	25	66252833116
		7,0x16,0	ZA 24 S	25	66252831403*
	115	7,0x22,23	ZA 24 S	25	66252831413
			ZA 24 R	25	66252831412
	125	7,0x22,23	ZA 30 Z	25	66252829673
			ZA 24 S	25	66252831422
			ZA 24 R	25	66252831421
	150	7,0x22,23	ZA 24 Q	25	66252832747
			ZA 24 S	25	66252832732*
			ZA 24 R	25	66252833119*
	180	7,0x22,23	ZA 30 Z	25	66252831429
			ZA 24 S	25	66252831434
			ZA 24 R	25	66252831433
	230	7,0x22,23	ZA 24 Q	25	66252832745*
ZA 30 Z			25	66252831438	
ZA 24 R			25	66252831446	
ZA 24 S			25	66252831447	
		7,0x22,23	ZA 24 Q	25	66252832746

\* Made-to-order

**Dimensions Key:** DIA = Diameter, T = Thickness, B = Bore





TYPE 41

TYPE 42



TYPE	DIA (mm)	TxB (mm)	SPECIFICATION	PK QTY	ART NO.
41	115	1,0x22,23	ZA 46 Z	25	66252829663
		1,6x22,23	ZA 46 T	25	66252829496
		2,0x22,23	ZA 36 Z	25	66252831458
	125	1,0x22,23	ZA 46 Z	25	66252832682
		1,6x22,23	ZA 46 T	25	66252829577
		2,0x22,23	ZA 36 Z	25	66252831463
		2,5x22,23	ZA 36 Z	25	66252833117
	150	2,0x22,23	ZA 36 Z	25	66252833118
	180	1,6x22,23	ZA 24 S	25	66252832870
		2,0x22,23	ZA 36 Z	25	66252831469
		2,5x22,23	ZA 36 Z	25	66252832734
	230	1,9x22,23	ZA 46 Z	25	66252832683
2,0x22,23		ZA 36 Z	25	66252831478	
2,5x22,23		ZA 36 Z	25	66252831474	
42	100	3,2x16,0	ZA 24 S	25	66252831502*
	115	2,5x22,23	ZA 36 Z	25	66252831506*
		3,2x22,23	ZA 30 T	25	66252831510
	125	2,5x22,23	ZA 36 Z	25	66252831516
		3,2x22,23	ZA 30 T	25	66252831519
		4,0x22,23	ZA 30 T	25	66252832684
		4,0x22,23	ZA 30 R	25	66252950962
	150	3,2x22,23	ZA 30 T	25	66252832731
	180	2,5x22,23	ZA 36 Z	25	66252831524
		3,2x22,23	ZA 30 T	25	66252831527
		4,0x22,23	ZA 30 T	25	66252832871
	230	2,5x22,23	ZA 36 Z	25	66252831529
		3,2x22,23	ZA 30 T	25	66252831532
		4,0x22,23	ZA 30 R	25	66252950964

\* Made-to-order

## FOUNDRY X



Norton Foundry X grinding wheels have been designed to find the perfect balance between material removal and wheel life. The coarse grit and zirconia grains ensure a high metal removal rate. Foundry X grinding wheels have been designed for High Frequency grinders used in the professional market for rough applications in the toughest environment. Try them out now.

### FEATURES

- Optimized combination of course zirconia and aluminium oxide grains
- Extra reinforcement applied
- Specially developed soft bond system in the Foundry X Comfort
- High Zirconia percentage and hard bond for long life in the Foundry X Long Life

### BENEFITS

- Fit for high frequency grinders, the safest solution in demanding applications
- Maximum user comfort, easy to use and less fatigue
- High material removal, better through put, time saving and cost reduction
- Long life and highly effective, increased productivity

TYPE	DIA (mm)	TxB (mm)	SPECIFICATION	PK QTY	ART NO.
27 HF**	180	7,0x22,23	ZA 24 T Long Life	10	66253371162
		7,0x22,23	ZA 20 R Comfort	10	66253370493*
	230	7,0x22,23	ZA 24 T Long Life	10	66253371175
		7,0x22,23	ZA 20 R Comfort	10	66252842546*
27	125	7,0x22,23	ZA 24 T Long Life	10	66253371176

\* Made-to-order

\*\* Optimized for use on high power machines

**Dimensions Key:** DIA = Diameter, T = Thickness, B = Bore

## NORZON FOUNDRY

The Norton Foundry depressed centre wheels feature a blend of aggressive Norzon and versatile aluminium oxide grain that provides a performance advantage on a wide range of ferrous and non-ferrous materials. Norton's advanced resin bond maximizes the cutting ability while maximizing wheel wear. The end result is a wheel that outlasts and outperforms competitive wheels while lowering the costs of cleaning castings.

### FEATURES

- Premium combination of zirconia grain and advanced bond system
- Q-Soft grade
- R-Medium grade
- S-Hard grade

### BENEFITS

- Superior performance compared to standard aluminum oxide wheels
- Highest productivity & lowest cost per cut
- Designed for steel, stainless steel, casts & white, grey & nodular cast iron applications
- For comfortable working
- Fast material removal
- Long wheel life



TYPE	DIA (mm)	TxB (mm)	SPECIFICATION	PK QTY	ART NO.
42	115	3,2x22,23	ZA 36 T	25	66252833137*
		3,2x22,23	ZA 36 T	25	66252829555
	125	4,6x22,23	ZA 30 Z	25	66252833140
		3,2x22,23	ZA 30 T	25	66252833144*
		4,0x22,23	ZA 30 T	25	66252833223
		4,6x22,23	ZA 30 Z	25	66252832716
	230	3,2x22,23	ZA 30 T	25	66252831531
		4,0x22,23	ZA 30 T	25	66252833147
		4,6x22,23	ZA 30 Z	25	66252833037

\* Made-to-order





TYPE	DIA (mm)	TxB (mm)	SPECIFICATION	PK QTY	ART NO.
27	115	7,0x22,23	ZA 30 S	25	66252832712*
			ZA 30 Z	25	66252832956
	125	7,0x22,23	ZA 30 S	25	66252829391
			ZA 30 S	25	66252833036
	150	7,0x22,23	ZA 30 Q	25	66252833224
			ZA 24 S	25	66252832724
	180	7,0x22,23	ZA 30 R	25	66252832723*
			ZA 24 S	25	66252831435
	230	7,0x22,23	ZA 24 R	25	66252832717
			ZA 24 Q	25	66252832692
			ZA 24 S	25	66252831448
				ZA 24 R	25
			ZA 30 Q	25	66252832693

\* Made-to-order

**Dimensions Key:** DIA = Diameter, T = Thickness, B = Bore

CUTTING-OFF  
& GRINDING  
WHEELS

COATED  
ABRASIVES  
& BEARTEX

BONDED  
ABRASIVES

SUPER  
ABRASIVES

DIAMOND  
TOOLS

CLEANING,  
POLISHING  
& MASKING

PERSONAL  
PROTECTION  
EQUIPMENT

TECHNICAL  
INFORMATION



## MULTI-PURPOSE

**TYPE 41**

### FEATURES

- Cuts all materials
- Ultra thin
- Unique construction
- Low vibration
- Free of iron

### BENEFITS

- No more time loss due to machine or product changing
- Quicker cut with no contamination
- Less noise, dust & material loss
- Extremely precise straight cuts with burr-free results
- Reduced energy consumption
- Counteracts loading & wheelglazing when cutting non-ferrous or plastics

TYPE	DIA (mm)	TxB (mm)	SPECIFICATION	PK QTY	ART NO.
41	115	1,0x22,23	C 60 T	25	66252833258
		1,6x22,23	C 46 T	25	66252828951
	125	1,0x22,23	C 60 T	25	66252918924
		1,6x22,23	C 46 T	25	66252828952
	180	1,6x22,23	C 46 T	25	66252926730
	230	1,9x22,23	C 46 T	25	66252918925

# ALU



Norton Aluminium sets an industrial performance standard amongst conventional aluminum oxide grain technologies. It provides optimum performance to price ratio throughout all aluminum applications.

### FEATURES

- Advanced grain & bond system
- Suitable for aluminium applications
- Unique grain & bond system optimised for non-ferrous

### BENEFITS

- Longer product life & faster material removal
- No more time loss due to machine or product changing
- Counteracts loading & wheelglazing when cutting non-ferrous
- Longer product life & quicker cutting

TYPE	DIA (mm)	TxB (mm)	SPECIFICATION	PK QTY	ART NO.
27	125	7,0x22,23	A 36 Q	10	66252828228
	180	7,0x22,23	A 36 Q	10	66252828230
	230	7,0x22,23	A 36 Q	10	66252828232
41	115	1,0x22,23	A 60 Q	25	66252828236
		1,6x22,23	A 46 Q	25	66252828233
	125	1,0x22,23	A 60 Q	25	66252828237
		1,6x22,23	A 46 Q	25	66252828234
		2,5x22,23	A 36 Q	25	66252828227
	180	2,5x22,23	A 36 Q	25	66252828229
230	1,9x22,23	A 46 Q	25	66252828235	
42	230	3,0x22,23	A 36 Q	25	66252828231

**Dimensions Key:** DIA = Diameter, T = Thickness, B = Bore



## OCTOPUS

METAL  
INOX

TYPE 29



30°

## FEATURES

- Unique patterned face
- Visible surface
- Grinding & polishing with one product
- 2 grit sizes
- Low vibration
- No backing pad needed

## BENEFITS

- Prevents loading
- Cooler operation
- Complete vision of the grinding zone
- More effective as less rework needed
- No more lost time due to machine or product changing
- 36 grit for stock removal
- 60 grit for polishing

TYPE	DIA (mm)	TxB (mm)	SPECIFICATION	PK QTY	ART NO.
29	115	4,0x22,23	A 36 T	20	66252829991
			A 60 T	20	66252829992
	125	4,0x22,23	A 36 T	20	66252829993
			A 60 T	20	66252829994

# VULCAN



TYPE 41

TYPE 42



## FEATURES

- For steel and stainless steel
- Free of iron, sulphur & chlorine
- Sharp aluminum oxide grains
- 80m/s

## BENEFITS

- No more lost time due to changing product or machine
- No stainless steel contamination
- Longer life and higher material removal
- High stability for straight cutting

TYPE	DIA (mm)	TxB (mm)	SPECIFICATION	PK QTY	ART NO.
41	115	1,0x22,23	A 60 S	25	66252925431**
		1,6x22,23	A 46 S	25	66252925432**
		2,0x22,23	A 30 S	25	66252925437**
		2,5x22,23	A 30 S	25	66252925442**
		3,0x22,23	A 30 S	25	66252925447**
	125	1,0x22,23	A 60 S	25	66252925433**
		1,6x22,23	A 46 S	25	66252925434**
		2,0x22,23	A 30 S	25	66252925438**
		2,5x22,23	A 30 S	25	66252925443**
		3,0x22,23	A 30 S	25	66252925448**
	150	2,0x22,23	A 30 S	25	66252925439**
		2,5x22,23	A 30 S	25	66252925444**
	180	1,6x22,23	A 46 S	25	66252925435**
		2,0x22,23	A 30 S	25	66252925440**
		2,5x22,23	A 30 S	25	66252925445**
		3,0x22,23	A 30 R	25	66252840200**
		3,0x22,23	A 30 S	25	66252925449**
	230	1,9x22,23	A 46 S	25	66252925436**
		2,0x22,23	A 30 S	25	66252925441**
		2,5x22,23	A 30 S	25	66252925446**
3,0x22,23		A 30 R	25	66252840202**	
3,0x22,23		A 30 S	25	66252925450**	
42	100	3,2x22,23	A 30 S	25	66252835417**
		2,5x22,23	A 30 S	25	66252925490**
	115	3,2x22,23	A 30 S	25	66252925494**
		2,5x22,23	A 30 S	25	66252925491**
	125	3,2x22,23	A 30 S	25	66252925495**
		3,2x22,23	A 30 S	25	66252925496**
	150	2,5x22,23	A 30 S	25	66252925492**
		3,2x22,23	A 30 S	25	66252925497**
	180	2,5x22,23	A 30 S	25	66252925493**
		3,2x22,23	A 30 S	25	66252925498**

\* Made-to-order

\*\* +30% performance upgrade

Dimensions Key: DIA = Diameter, T = Thickness, B = Bore

CUTTING-OFF & GRINDING WHEELS

COATED ABRASIVES & BEARTEX

BONDED ABRASIVES

SUPER ABRASIVES

DIAMOND TOOLS

CLEANING, POLISHING & MASKING

PERSONAL PROTECTION EQUIPMENT

TECHNICAL INFORMATION

## VULCAN



TYPE 27



## FEATURES

- Designed to cut steel and stainless steel
- Free of iron, sulphur & chlorine
- Sharp aluminum oxide grains
- S-Hard grade

## BENEFITS

- No more lost time due to changing product or machine
- No stainless steel contamination
- Longer life and higher material removal

TYPE	DIA (mm)	TxB (mm)	SPECIFICATION	PK QTY	ART NO.	
27	100	6,4x16,0	A 30 S	10	66252926667*	
		4,0x22,23	A 30 S	10	66252925518*	
	115	6,4x22,23	A 30 S	10	66252925522	
		4,0x22,23	A 30 S	10	66252925519	
		6,4x22,23	A 30 S	10	66252925523**	
	125	8,0x22,23	A 30 S	10	66252925524	
		6,4x22,23	A 30 S	10	66252925525	
	150	6,4x22,23	10,0x22,23	A 30 S	10	66252925528
			4,0x22,23	A 30 S	10	66252925520
			6,4x22,23	A 30 S	10	66252925526
	180	6,4x22,23	8,0x22,23	A 30 S	10	66252925527
			10,0x22,23	A 30 S	10	66252925531*
			4,0x22,23	A 30 S	10	66252925521
			6,4x22,23	A 30 S	10	66252925529
230	6,4x22,23	8,0x22,23	A 30 S	10	66252925530	

\* Made-to-order \*\* +30% performance upgrade

## VULCAN FAST CUT



TYPE 27



## FEATURES

- Sharp aluminium oxide grains
- Specially designed to cut steel and stainless steel
- Free of iron, sulphur & chlorine
- P-Medium grade

## BENEFITS

- Fast material removal
- Comfortable grinding
- No stainless steel contamination

TYPE	DIA (mm)	TxB (mm)	SPECIFICATION	PK QTY	ART NO.	
27	115	6,4x22,23	A 30 P	10	66252830803	
		125	6,4x22,23	A 30 P	10	66252830804**
	150	6,4x22,23	A 30 P	10	66252831014*	
		6,4x22,23	A 30 P	10	66252830805	
	180	6,4x22,23	8,0x22,23	A 30 P	10	66252830806*
			230	6,4x22,23	A 30 P	10

\* Made-to-order \*\* +30% performance upgrade



# VULCAN



## FEATURES

- Dedicated for stainless steel
- Free of iron, sulphur & chlorine
- Sharp aluminum oxide grains

## BENEFITS

- Fast and comfortable cutting and grinding
- No stainless steel contamination
- Longer life and higher material removal

TYPE	DIA (mm)	TxB (mm)	SPECIFICATION	PK QTY	ART NO.
27	115	6,4x22,23	A 30 S Inox	10	66252925513
	125	6,4x22,23	A 30 S Inox	10	66252925514
	150	6,4x22,23	A 30 S Inox	10	66252925515*
	180	6,4x22,23	A 30 S Inox	10	66252925516
	230	6,4x22,23	A 30 S Inox	10	66252925517
41	115	1,0x22,23	A 60 T Inox	25	66252833400
		1,6x22,23	A 46 T Inox	25	66252833401
		2,0x22,23	A 30 S Inox	25	66252835281*
		2,5x22,23	A 30 S Inox	25	66252833408*
	125	1,0x22,23	A 60 T Inox	25	66252833402
		1,6x22,23	A 46 T Inox	25	66252833403
		2,0x22,23	A 30 S Inox	25	66252835282*
		2,5x22,23	A 30 S Inox	25	66252833409
	150	1,6x22,23	A 46 T Inox	25	66252833404
		2,0x22,23	A 30 S Inox	25	66252835283*
		2,5x22,23	A 30 S Inox	25	66252833410*
	180	1,6x22,23	A 46 T Inox	25	66252833405*
		2,0x22,23	A 30 S Inox	25	66252835284*
		2,5x22,23	A 30 S Inox	25	66252925426*
	230	1,9x22,23	A 46 T Inox	25	66252833406
		2,0x22,23	A 30 S Inox	25	66252835285*
42	100	2,5x16,0	A 30 S Inox	25	66252925485*
	115	2,5x22,23	A 30 S Inox	25	66252925486*
	125	2,5x22,23	A 30 S Inox	25	66252925487
	180	2,5x22,23	A 30 S Inox	25	66252925488*
	230	2,5x22,23	A 30 S Inox	25	66252925489

\* Made-to-order

**Dimensions Key:** DIA = Diameter, T = Thickness, B = Bore

CUTTING-OFF & GRINDING WHEELS

COATED ABRASIVES & BEARTEX

BONDED ABRASIVES

SUPER ABRASIVES

DIAMOND TOOLS

CLEANING, POLISHING & MASKING

PERSONAL PROTECTION EQUIPMENT

TECHNICAL INFORMATION

## VULCAN



TYPE 27

TYPE 41

TYPE 42



## FEATURES

- Dedicated for stone
- Sharp silicon carbide grains

## BENEFITS

- Fast and comfortable cutting and grinding
- Longer life and higher material removal

TYPE	DIA (mm)	TxB (mm)	SPECIFICATION	PK QTY	ART NO.
27	100	6,4x16,0	C 30 R	10	66252925532*
	115	6,4x22,23	C 30 R	10	66252925533
	125	6,4x22,23	C 30 R	10	66252925534
	180	6,4x22,23	C 30 R	10	66252925535
	230	6,4x22,23	C 30 R	10	66252925537
41	115	3,0x22,23	C 30 R	25	66252925452
	125	3,0x22,23	C 30 R	25	66252925453
	150	3,0x22,23	C 30 R	25	66252925454*
	180	3,0x22,23	C 30 R	25	66252925455*
	230	3,0x22,23	C 30 R	25	66252925456
42	100	3,2x16,0	C 30 R	25	66252925499*
	115	3,2x22,23	C 30 R	25	66252925500
	125	3,2x22,23	C 30 R	25	66252925501
	180	3,2x22,23	C 30 R	25	66252925502*
	230	3,2x22,23	C 30 R	25	66252925503

\* Made-to-order

## VULCAN WITH NORZON TECHNOLOGY



TYPE 27



## FEATURES

- Combination of zirconia and aluminium oxide grain
- Suitable for steel and cast iron applications

## BENEFITS

- Highest productivity
- Fast material removal
- Easy & comfortable grinding

TYPE	DIA (mm)	TxB (mm)	SPECIFICATION	PK QTY	ART NO.
27	125	7,0x22,23	ZA 24 R	10	66252838104
	150	7,0x22,23	ZA 24 R	10	66252838105*
	180	7,0x22,23	ZA 24 R	10	66252838106*
	230	7,0x22,23	ZA 24 R	10	66252838107*

\* Made-to-order

# STARLINE

**GOOD +++**

Norton Starline provides a complete, convenient offer for all metal work applications with a full range of sizes for angle grinders. Provides good material removal rates, fast cutting, reduced vibration for comfortable working and consistent performance for improved part quality.

**FEATURES**

- Suitable for steel, stainless steel, cast iron and stone

**BENEFITS**

- Fast material removal
- Good price / quality ratio



TYPE	DIA (mm)	TxB (mm)	SPECIFICATION	PK QTY	ART NO.
41	115	1,0x22,23	A 60 R	25	66252837243**
		1,0x22,23	A 60 R - SET*	10	66252837575**
	125	1,0x22,23	A 60 R	25	66252837245**
		1,0x22,23	A 60 R - SET*	10	66252837576**
		1,6x22,23	A 46 R	25	66252837246**
		1,6x22,23	A 46 R - SET*	10	66252837577**
	180	1,6x22,23	A 46 R	25	66252837247**
	230	2,0x22,23	A 36 R	25	66252837248

\* Minimum order quantity - 20 sets  
\*\* +30% performance upgrade

**Dimensions Key:** DIA = Diameter, T = Thickness, B = Bore

CUTTING-OFF & GRINDING WHEELS

COATED ABRASIVES & BEARTEX

BONDED ABRASIVES

SUPER ABRASIVES

DIAMOND TOOLS

CLEANING, POLISHING & MASKING

PERSONAL PROTECTION EQUIPMENT

TECHNICAL INFORMATION





TYPE 27

TYPE 41

TYPE 42



TYPE	DIA (mm)	TxB (mm)	SPECIFICATION	PK QTY	ART NO.
27	115	6,0x22,23	A 24 Q	10	66252837263
	125	6,0x22,23	A 24 Q	10	66252837264**
	180	6,0x22,23	A 24 Q	10	66252837268
	230	6,0x22,23	A 24 Q	10	66252837269
41	115	2,5x22,23	A 30 P	25	66252837249
	125	2,5x22,23	A 30 P	25	66252837250
	180	2,5x22,23	A 30 P	25	66252837251
	230	2,5x22,23	A 30 P	25	66252837253
42	115	3,0x22,23	A 30 P	25	66252837275*
	125	3,0x22,23	A 30 P	25	66252837276
	180	3,0x22,23	A 30 P	25	66252837277
	230	3,0x22,23	A 30 P	25	66252837278

\* Made-to-order  
\*\* +30% performance upgrade



TYPE 42



TYPE	DIA (mm)	TxB (mm)	SPECIFICATION	PK QTY	ART NO.
42	230	3,0x22,23	C 30 R	25	66252837284

# WHEELS FOR PETROL SAWS

Norton's wide range of cutting wheels for petrol saws provide high value and high performance industrial solutions.

## APPLICATIONS & MARKETS

- Construction
- Demolition



CUTTING-OFF & GRINDING WHEELS

COATED ABRASIVES & BEARTEX

BONDED ABRASIVES

SUPER ABRASIVES

DIAMOND TOOLS

CLEANING, POLISHING & MASKING

PERSONAL PROTECTION EQUIPMENT

TECHNICAL INFORMATION

## VULCAN

BETTER ++++

### FEATURES

- Designed for petrol and electrical saws
- Sharp silicon carbide and aluminum oxide grains
- 80m/s

### BENEFITS

- Optimized for cutting steel, stone, bricks and concrete
- Longer life and fast cutting
- High stability for straight cutting



TYPE	DIA (mm)	TxB (mm)	SPECIFICATION	PK QTY	ART NO.
41	300	3,5x20,0	A 30 S	10	66252925457
		3,5x22,23	A 30 S	10	66252925458*
		3,5x25,4	A 30 S	10	66252925459*

\* Made-to-order

**Dimensions Key:** DIA = Diameter, T = Thickness, B = Bore

# WHEELS FOR CHOP SAWS

Norton's wide range of cutting wheels for chop saws provide high value and high performance industrial solutions.

## APPLICATIONS & MARKETS

- Construction
- Fabrication
- Foundry
- Maintenance



CUTTING-OFF  
& GRINDING  
WHEELS

COATED  
ABRASIVES  
& BEARTEX

BONDED  
ABRASIVES

SUPER  
ABRASIVES

DIAMOND  
TOOLS

CLEANING,  
POLISHING  
& MASKING

PERSONAL  
PROTECTION  
EQUIPMENT

TECHNICAL  
INFORMATION

BETTER ++++

## VULCAN



TYPE 41



### FEATURES

- Advanced grain and bond system
- High quality mechanical reinforcement
- 80m/s

### BENEFITS

- Longer wheel life
- Quick and free cutting
- Maximum safety
- High stability for straight cutting
- Designed for portable metal chop saws and for fixed machines

TYPE	DIA (mm)	TxB (mm)	SPECIFICATION	PK QTY	ART NO.	
41	300	2,8x25,4	A 30 S	10	66252925460*	
		3,0x25,4	A 30 S	10	66252925462	
	350	3,0x32,0	A 30 S	10	66252925463*	
		400	3,2x25,4	A 30 S	10	66252925464*
			3,2x32,0	A 30 S	10	66252925465*

\* Made-to-order



# WHEELS FOR RAIL

The Norton Rail range provides high performance wheels for demanding operations. Rail cutting requires precision, speed and power and Norton Rail is a complete program of cutting wheels suitable for any rail type (subway, tram, train) and any rail cutting machine with a clamping device (electrical and petrol).

## APPLICATIONS & MARKETS

- Rail industry



CUTTING-OFF  
& GRINDING  
WHEELS

COATED  
ABRASIVES  
& BEARTEX

BONDED  
ABRASIVES

SUPER  
ABRASIVES

DIAMOND  
TOOLS

CLEANING,  
POLISHING  
& MASKING

PERSONAL  
PROTECTION  
EQUIPMENT

TECHNICAL  
INFORMATION

## RAIL

BETTER ++++

### FEATURES

- Sharp aluminum oxide grain & optimized bond
- Zirconia grain & optimized bond
- Optimized bond and wheel density
- 3 specifications available: soft, medium, hard
- Glass cloth reinforcement

### BENEFITS

- Precise cut
- Fast cutting speed
- White cuts and free cutting
- Optimised for use on steel and railways
- Perfect straight cut without any deviation
- Low vibration on the machine for better user comfort and longer work periods
- Consistent performance for improved quality of cut
- Minimal wheel wear
- Covers all rail machine horsepower and all rail types: subway, tramway, train
- Suitable for use on powerful machines running at 100m/s for 350mm wheels and 80m/s for 300mm wheels
- Maximum safety for the operator



RAIL  
METAL

TYPE 41



TYPE	DIA (mm)	TxB (mm)	SPECIFICATION	PK QTY	INNOVATION
					ART NO.
41	350	4,0x25,4	ZA 24 Q	10	66252830924
	400	4,0x25,4	ZA 24 Q	10	66252833665

Dimensions Key: DIA = Diameter, T = Thickness, B = Bore

RAIL  
METAL

TYPE 41



90°



TYPE	DIA (mm)	TxB (mm)	SPECIFICATION	PK QTY	ART NO.
41	300	3,5x20,0	A 24 T	10	66252829589
		4,0x20,0	A 24 T	10	66252829586
		4,0x22,23	A 24 T	10	66252829587
	350	4,0x25,4	ZA 24 T	10	66252832744
			A 24 T	10	66252829588
			A 24 P	10	66252828620
			A 24 Q	10	66252833554
	400	4,0x25,4	A 24 P	10	66252919130

# WHEELS FOR STATIONARY MACHINES

Norton's wide range of cutting wheels for stationary machines provide high value and high performance industrial solutions.

## APPLICATIONS & MARKETS

- Construction
- Fabrication
- Foundry



CUTTING-OFF & GRINDING WHEELS

COATED ABRASIVES & BEARTEX

BONDED ABRASIVES

SUPER ABRASIVES

DIAMOND TOOLS

CLEANING, POLISHING & MASKING

PERSONAL PROTECTION EQUIPMENT

TECHNICAL INFORMATION

## VULCAN

BETTER ++++

### FEATURES

- Advanced grain bond system
- Optimised for cutting steel, stainless steel, concrete and cast iron
- Double, full external mechanical reinforcement
- 80m/s

### BENEFITS

- Longer wheel life
- Quick and free cutting
- Cutting without burn layers and splinters
- No contamination of stainless steel
- Maximum safety
- High stability and straight cutting
- Designed for fixed machines



TYPE	DIA (mm)	TxB (mm)	SPECIFICATION	PK QTY	ART NO.
41	300	3,5x32,0	C 30 R	10	66252925482*
	350	4,0x32,0	C 30 R	10	66252925483
	400	4,5x32,0	C 30 R	10	66252925484
		5,0x32,0	C 24 R	10	66252838304*

\* Made-to-order

**Dimensions Key:** DIA = Diameter, T = Thickness, B = Bore





METAL

TYPE 41



90°

TYPE	DIA (mm)	TxB (mm)	SPECIFICATION	SPEED [m/s]	PK QTY	ART NO.	
41	300	3,0x32,0	A 30 S	80	10	66252925466	
		3,0x32,0	A 30 S	100	10	66252925475	
		3,0x32,0	A 30 T	80	10	66252843820*	
		3,5x25,4	A 30 S	80	10	66252925467*	
		3,5x30,0	A 30 S	80	10	66252835384*	
		3,5x32,0	A 30 S	80	10	66252925468	
	350	3,5x32,0	A 30 S	100	10	66252836858*	
		3,5x25,4	A 30 S	80	10	66252925469	
		3,5x32,0	A 30 S	80	10	66252925470	
		3,5x32,0	A 30 S	100	10	66252925476	
	400	4,0x32,0	A 30 S	80	10	66252925471	
		3,5x25,4	A 30 S	80	10	66252833890*	
		4,0x25,4	A 30 S	80	10	66252925472	
		4,0x25,4	A 30 S	100	10	66252925477	
		4,0x32,0	A 30 S	80	10	66252925473	
		4,0x32,0	A 30 S	100	10	66252925478	
			4,5x32,0	A 30 S	80	10	66252925474
			4,0x40,0	A 30 S	80	10	66252830812*

\* Made-to-order



INOX

TYPE 41



90°

TYPE	DIA (mm)	TxB (mm)	SPECIFICATION	PK QTY	ART NO.
41	300	3,0x32,0	A 30 S	10	66252830808*
	350	3,5x32,0	A 30 S	10	66252833646
	400	4,0x32,0	A 30 S	10	66252830811*

\* Made-to-order

# STARLINE

**GOOD +++**



**TYPE 41**



### FEATURES

- Dedicated for steel

### BENEFITS

- Good price/quality ratio
- Stable cut

TYPE	DIA (mm)	TxB (mm)	SPECIFICATION	PK QTY	ART NO.
41	300	3,0x32,0	A 30 R	10	66252843841
	350	3,5x32,0	A 30 R	10	66252843842
	400	4,0x32,0	A 30 R	10	66252843843

**Dimensions Key:** DIA = Diameter, T = Thickness, B = Bore

CUTTING-OFF & GRINDING WHEELS

COATED ABRASIVES & BEARTEX

BONDED ABRASIVES

SUPER ABRASIVES

DIAMOND TOOLS

CLEANING, POLISHING & MASKING

PERSONAL PROTECTION EQUIPMENT

TECHNICAL INFORMATION







# 71-292

# COATED ABRASIVES & BEARTEX NON-WOVENS



COATED  
ABRASIVES  
& BEARTEX

BONDED  
ABRASIVES

SUPER  
ABRASIVES

DIAMOND  
TOOLS

CLEANING,  
POLISHING  
& MASKING

PERSONAL  
PROTECTION  
EQUIPMENT

TECHNICAL  
INFORMATION

72 Index by Product  
73 Index by Machine Type  
74 Introduction  
89 Angle Grinder  
117 Mini Grinder  
141 Die Grinder  
171 Disc Sanders

197 Orbital Straight Sheet  
Sander/Sanding Block  
209 Hand Sanding  
229 File Belt Machine  
235 Portable Belt Sander  
239 Backstand Machine  
251 Bench/Pedestal Grinder

265 Satinex Machine  
271 Wide Belts  
273 Products for wall,  
floor & ceiling sanding  
285 Shoe Manufacture  
& Repair  
289 Glass Arising

# INDEX BY PRODUCT

COATED  
ABRASIVES  
& BEARTEX



FIBRE DISCS  
90-93



FLAP DISCS  
94-101



SEMI-FLEXIBLE  
DISCS  
102-103



RAPID BLEND DISCS  
DEPRESSED CENTRE  
105-107



RAPID PREP SURFACE  
BLENDING DISCS  
108-112



RAPID STRIP DISCS  
DEPRESSED CENTRE  
113-114,  
134-135

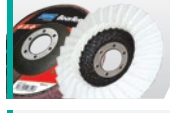

BEARTEX FLAP DISC  
& RAPID POLISH  
115-116



SPEEDLOK  
COATED DISCS  
121-127,  
133-139

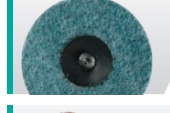

RAPID  
SPEEDLOK DISCS  
128-132



SPINDLE MOUNTED  
FLAP WHEELS  
142-150

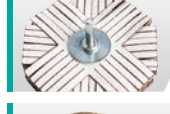

SPECIALITIES



RAPID BLEND  
UNITISED WHEELS  
165-168



ACCESSORIES  
FOR DIE GRINDER  
169



MULTI-AIR DISCS  
172-180



SELF-GRIP<sup>+</sup> & SOFT  
TOUCH DISCS  
181-193



SELF-ADHESIVE  
DISCS  
194-196



CUT SHEETS  
198-204



SELF-GRIP<sup>+</sup> PAPER  
ROLLS  
205-206



BEARTEX ROLLS  
207-208

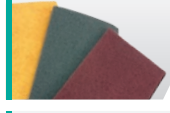

SHEETS &  
HAND PADS  
210-215

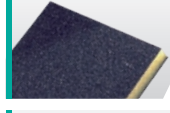

ABRASIVE  
SPONGES  
216-217



ROLLS &  
CLOTH ROLLS  
218-223



HANDY ROLLS  
224-226



ROTOLO  
FOAM ROLLS  
227-228



FILE BELTS  
230-234



PORTABLE BELTS  
236-238



NARROW BELTS  
240-248



SURFACE  
BLENDING BELTS  
249-250



FLANGE MOUNTED  
FLAP WHEELS  
252-256



RAPID FINISH  
CONVOLUTE WHEELS  
257-263



HIGH STRENGTH  
DISCS  
264



LAP MOPS  
264



WHEELS FOR  
SATINEX MACHINES  
268-269



WIDE BELTS  
272



BELTS  
274-276,  
286

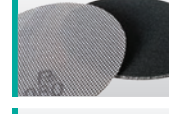

SCREENBACK DISCS  
279



PLAIN DISCS  
280-281



BEARTEX  
FLOOR PADS  
282-283



CONES &  
NAUMKEAG CAPS  
287-288



BELTS FOR  
GLASS  
290-292

BONDED  
ABRASIVES

SUPER  
ABRASIVES

DIAMOND  
TOOLS

CLEANING,  
POLISHING  
& MASKING

PERSONAL  
PROTECTION  
EQUIPMENT

TECHNICAL  
INFORMATION

\* To help better describe the abrasive fixing system we have changed the name from 'NorGrip' to 'Self-Grip'.

# INDEX BY MACHINE TYPE

## ANGLE GRINDER



Fibre Discs	90
Flap Discs	94
Semi Flexible Discs	102
Blending	105
Stripping & Cleaning	113
Finishing & Polishing	115

## MINI GRINDER



Mini Flap Discs	118
Speedlok Discs	121
Blending	128
Surface Preparation	131
Stripping & Cleaning	134
Polishing	136

## DIE GRINDER

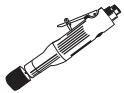

Spindle Mounted Flap Wheels	142
Specialties	
Rapid Blend Unitised Wheels	165
Accessories for Die Grinder	169

## DISC SANDERS



Introduction	172
Multi-Air Discs	174
Self-Grip <sup>†</sup> & Soft-Touch Discs	181
Backup Pads	191
Self-Adhesive Discs	194

## ORBITAL STRAIGHT SHEET SANDER/SANDING BLOCK



Cut Sheets	198
Self-Grip <sup>†</sup> Paper Rolls	205
Beartex Rolls	207

## HAND SANDING



Sheets & Hand Pads	210
Beartex Sheets & Hand Pads	214
Abrasive Sponges	216
Paper Rolls	218
Cloth Rolls	222
Handy Rolls	224
Rotolo Foam Rolls	227

## FILE BELT MACHINE



File Belts	230
Beartex Surface Blending File Belts	233

## PORTABLE BELT SANDER



Portable Belts	236
----------------	-----

## BACKSTAND MACHINE

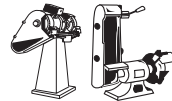

Narrow Belts for Metal	240
Narrow Belts for Wood	248
Surface Blending Belts	249

## BENCH/PEDESTAL GRINDER

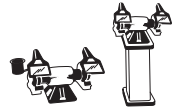

Flange Mounted Flap Wheels	252
Beartex Flange Mounted Flap Wheels	254
Rapid Finish Convolute Wheels	257
Convolute Wheels	262
High Strength Discs	264

## SATINEX MACHINE

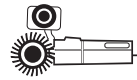

Flap Wheels for Satinex Machines	266
Wheels for Satinex Machines	268

## WIDE BELTS

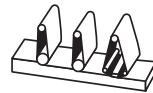

Wide Belts	272
------------	-----

## PRODUCTS FOR WALL, FLOOR & CEILING SANDING



Cloth Belts for Floor Sanding	274
Rolls for Floor Sanding	277
Screenback Discs for Wall & Ceiling Sanding	279
Plain Discs	280
Beartex Floor Pads	282

## SHOE REPAIR



Belts	286
Cones	287
Naumkeag Caps	288

## GLASS APPLICATIONS



Portable Belts	290
Cloth Belts	292

<sup>†</sup> To help better describe the abrasive fixing system we have changed the name from 'NorGrip' to 'Self-Grip'.

COATED  
ABRASIVES  
& BEARTEX

BONDED  
ABRASIVES

SUPER  
ABRASIVES

DIAMOND  
TOOLS

CLEANING,  
POLISHING  
& MASKING

PERSONAL  
PROTECTION  
EQUIPMENT

TECHNICAL  
INFORMATION



# INTRODUCTION

The Norton coated abrasive and Beartex product offering encompasses a complete range of belts, discs, rolls, sheets and flap wheels for all your polishing, welding, maintenance and repair operations needs. This extensive product range includes products designed for all types of application, including heavy stock removal, dimensioning, grinding, deburring, cleaning, blending, polishing and finishing operations.

## UNDERSTANDING THE PRODUCT

### COATED ABRASIVES

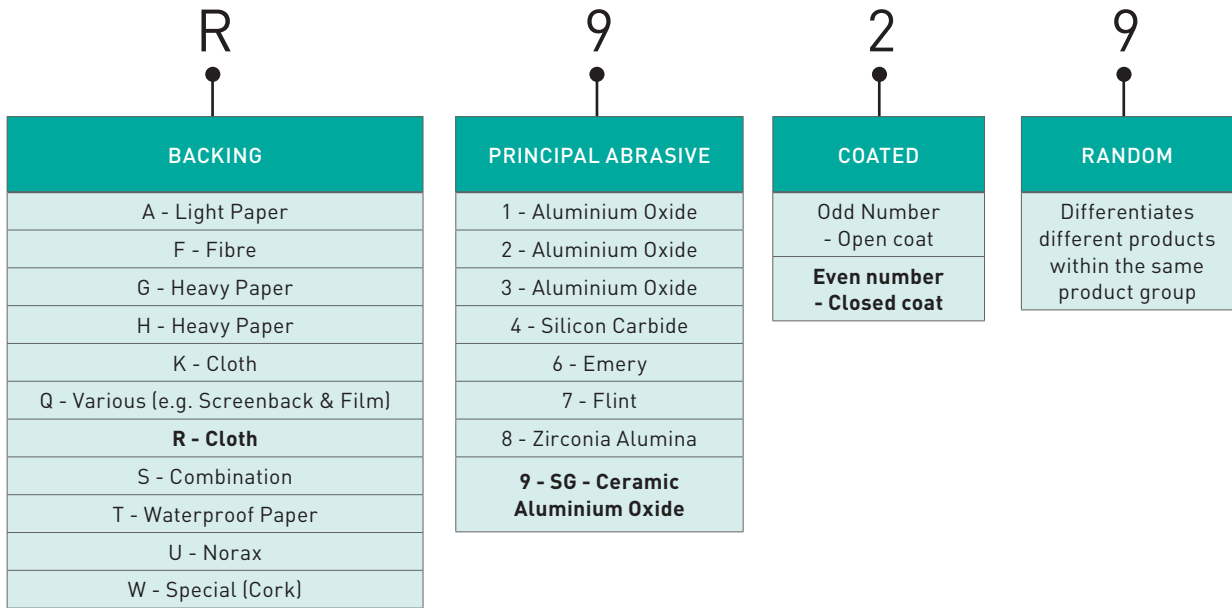

#### BACKING TYPES

Whether paper, cloth, vulcanised fibre or polyester film, the backing must be smooth enough for uniform adhesive coating, strong enough to withstand grinding pressures and flexible enough to conform to contours if necessary.

#### ABRASIVE BONDS

There are two main types of adhesives in use, one based on animal glue, and the more common based on synthetic heat hardenable resins. The adhesive is applied with a minimum of two bonding applications.

The first, or maker, coat adheres the abrasive grain to the backing ensuring proper anchoring and orientation. After drying, or curing, the second, or sizer, coat is applied. The sizer adhesive, united with the maker bond, provides final grain anchoring and the proper total adhesive level for the finished product.

#### ABRASIVE TYPES

The ideal abrasive grain offers maximum resistance to point wear, yet fractures before serious dulling occurs, thereby satisfying both stock removal and finishing requirements.

#### NATURAL ABRASIVES

Emery is a natural composite of corundum and iron oxide. The particles are blocky in shape and tend to cut slowly, thereby producing a polishing action on the material being abraded. Used for general maintenance and polishing of metals and in very fine grits for highly technical polishing, such as preparing metallurgical specimens requiring very close tolerances. Emery products are black in colour.

## SYNTHETIC ABRASIVES

- Aluminium oxide is tough and well adapted to grinding high tensile materials, such as carbon steel, alloy steels, tough bronze and hard woods. Wherever toughness (ability to resist fracturing) is the main consideration, aluminium oxide out performs all other coated abrasive grains
- Silicon carbide is the hardest and sharpest of the minerals used in coated abrasives. Its hardness and sharpness make it the ideal abrasive for sanding non-ferrous metals (aluminium, brass, bronze, magnesium, titanium, etc.), rubber, glass, plastics, fibrous woods, enamel and other relatively soft materials. Silicon carbide is superior to any other abrasive in its ability to penetrate and cut faster under light pressure
- Zirconia alumina has a unique self-sharpening characteristic which gives it long life on rugged stock removal operations. Zirconia alumina is well suited for heavy grinding of metals and planing of wood, because the controlled fracturing of the grain continuously produces sharp, new abrading points
- Ceramic aluminium oxide is a long-lasting, tough, dense abrasive due to its micro structure. The extremely small micron size particles break off during grinding, producing multiple new cutting edges. As it stays sharp, especially when used in medium and high pressure operations, it cuts at a higher rate than other abrasives. Recommended for use on forged and carbon steels, high nickel and cobalt alloys.









## DIFFERENTIATION IN THE RANGE

Norton offers the industry's widest selection of coated abrasives to meet every customer requirement. The wide range of abrasive types used in the range are classified into 3 tiers by product shape (Best/ Better/ Good) to help you choose the right product for your specific application.

<b>BEST +++++</b> INNOVATION	Using unparalleled abrasive technology, and extremely high performance abrasive grains, Norton provides innovative product solutions dedicated to improving productivity in all industrial applications
<b>BEST +++++</b>	These technologically advanced products meet the demands of the most discerning user giving the highest productivity and the longest product life for the lowest operating costs
<b>BETTER +++++</b>	The core of the Norton Coated Abrasive offering. These products are designed to give superior performance solutions in all abrasive applications, giving high productivity levels and low total abrasive costs
<b>GOOD +++</b>	Standard Norton products that give highly durable solutions with good performance levels

## PRODUCT SELECTION GUIDE

Norton offers a diverse range of products that are suitable for all commonly encountered industrial applications. To enable more effective product selection an overview of appropriate products for the main applications is given in the following pages. Pictograms and colours are used to represent the applications and these are repeated with the product details in the main section.

 FERROUS	 NON-FERROUS	
 HARD WOOD	 SOFT WOOD	 PAINT & VARNISH
 GLASS ARISING		
 STONE		
 SHOE REPAIR		

For further information please go to the Technical Information Section at the back of this catalogue.

COATED ABRASIVES & BEARTEX

BONDED ABRASIVES

SUPER ABRASIVES

DIAMOND TOOLS

CLEANING, POLISHING & MASKING

PERSONAL PROTECTION EQUIPMENT

TECHNICAL INFORMATION

# PRODUCT AVAILABILITY TABLE

Key: Grit availability

	Standard Norton products		Available also in Self-Grip <sup>†</sup>
	Generic backprint		Soft-Touch
	Cancelled - stock will not be replenished		
	Planned		

Key: Shape availability

	Standard availability
	Specific availability (BSG only, P600 only, stock only)
	Restricted availability (no BFL)
	Available only in full jumbo width

## A,B,C WEIGHT PAPER PRODUCTS

PRODUCT CODE	BACKING	ABRASIVE	PRODUCT COLOUR	BOND	COMMENTS	USEABLE WIDTH (mm)	GRIT SIZE																		
							NO GRIT	5µ-3000	8µ-2500	10µ-2000	12µ-1500	16µ-1200	1000	800	600	500	400	360	320						
A213	B/C	AO	Beige	UF/UF	P36 to P80 with C-wt	Sheets																			
A233F	B/C	AO	Beige	UF/UF	No fil treatment with FSC paper. Availability in June 2013.	Sheets																			
A255	B	AO	Brown	UF/UF	Non stearate No Fil																				
A275	B/C	AO	Brown	UF/UF	No Fil, P80 to P120 in C-Weight. Finer in B-Weight	1380						S	S	S	▲	▲	▲	▲	▲	▲	▲	▲	▲	▲	▲
A975	B/C	SG/AO	Blue	UF/UF	No Fil, P80 to P120 in C-Weight. Finer in B-Weight	1380						S		S	▲	▲	▲	▲	▲	▲	▲	▲	▲	▲	▲
A726	C	Flint	Beige	G/G	Special flint grading	Stock sheets																			
A296	B	AO	Yellow	UF/UF	No Fil	1380																			

## WATERPROOF PAPER PRODUCTS

PRODUCT CODE	BACKING	ABRASIVE	PRODUCT COLOUR	BOND	COMMENTS	USEABLE WIDTH (mm)	GRIT SIZE																			
							4,000	5µ-3000	8µ-2500	10µ-2000	12µ-1500	16µ-1200	1000	800	600	500	400	360	320							
T100	B/C	AO	Red	PF/PF		Stock sheets																				
T221	C	AO	Black	PF/PF		Stock sheets																				
T489	B/C	SiC	Black	PF/PF	P60 to P150 in C-wt	Stock sheets																				
T417	B/C	SiC	Black	PF/PF	P60 to P150 in C-wt	Stock sheets																				
T401	A	SiC	Black	V/PF		Stock only																				
L41PC	C	SiC	Black		C-wt	482																				
T278	B/C	AO	Black	PF/PF	P60 to P150 in C-wt	Stock sheets																				

<sup>†</sup> To help better describe the abrasive fixing system we have changed the name from 'NorGrip' to 'Self-Grip'.

COATED ABRASIVES & BEARTEX

BONDED ABRASIVES

SUPER ABRASIVES

DIAMOND TOOLS

CLEANING, POLISHING & MASKING

PERSONAL PROTECTION EQUIPMENT

TECHNICAL INFORMATION



GRIT SIZE																SHAPE AVAILABILITY						
280	240	220	180	150	120	100	80	60	50	40	36	30	24	20	16	PRODUCT CODE	BELTS W ≤ 400mm	BELTS W > 400mm	DISCS	STD SHEETS	OTHER SHEETS	ROLLS
																A213				Stock		FW
																A233F				Stock		FW
																A255						
▲ S	▲ S	▲ S	▲ S	▲ S	▲ S	▲	▲									A275			▲ S	Stock	▲	FW/Rotolo
▲	▲	▲	▲	▲	▲		▲									A975			▲ S		▲	FW
				3/0	2/0	0	12	3	4	5	6					A726				Stock		
																A296			Stock			Rotolo

GRIT SIZE																SHAPE AVAILABILITY						
280	240	220	180	150	120	100	80	60	50	40	36	30	24	20	PRODUCT CODE	BELTS W ≤ 400mm	BELTS W > 400mm	DISCS	STD SHEETS	OTHER SHEETS	ROLLS	
															T100							FW
															T221				Stock			FW
															T489				Stock			FW
															T417				Stock			
															T401				Stock			
															L41PC				Stock			FW
															T278				Stock			

COATED ABRASIVES & BEARTEX

BONDED ABRASIVES

SUPER ABRASIVES

DIAMOND TOOLS

CLEANING, POLISHING & MASKING

PERSONAL PROTECTION EQUIPMENT

TECHNICAL INFORMATION

## E AND F WEIGHT PAPER PRODUCTS

PRODUCT CODE	BACKING	ABRASIVE	PRODUCT COLOUR	BOND	COMMENTS	USEABLE WIDTH (mm)	GRIT SIZE																
							NO GRIT	5µ-3000	8µ-2500	10µ-2000	12µ-1500	14µ-1200	1000	800	600	500	400	360	320				
G156F	E*	AO	Green	UF/UF	FSC paper	1380																	
A277	E*	AO	Salmon	UF/UF	No Fil	1380																	
G131F	E*	AO	Yellow	UF/G	FSC paper	1380																	
G133F	B /C	AO	Yellow	UF/G	FSC paper	1380																	
H216F	E*	AO	Brown	UF/G		1380																▲	
H259	F	AO	Maroon	PF/PF	Antistatic, open coat	1430																	
H231	F+	AO	Maroon	PF/PF	Antistatic, open coat	1430																▲	
H235	F	AO	Maroon	UF/UF	Open Coat	1430																▲	
H425	E,F	SiC	Black	UF, PF 240+f 220+C PF	Open coat	1430										▲	▲		▲		▲		
H835F Blue Fire	F	NZ/AO	Blue	PF/PF	FSC paper, open coat	1420																	
H822	F+	NZ	Blue	PF/PF	Closed coat	1420																	

E\* = 185gr F+ = 270gr

## FILM PRODUCTS

PRODUCT CODE	BACKING	ABRASIVE	PRODUCT COLOUR	BOND	COMMENTS	USEABLE WIDTH (mm)	GRIT SIZE																
							1µ	1.5µ	3µ	5µ-3000	6µ	7µ	8µ-2000	9µ	10µ-1500	12µ-1500	15µ-1200	18µ-1000	19µ-1000	20µ-800			
Q255	Foam	AO	Coloured by grit	PF	Velcro backing	1500																	
Q175 Pure Ice	3 mil film	AO White	White	UV	No Fil	Stock only											▲	▲	▲		▲		
Q275	3 mil film	AO White	Yellow	UV	No Fil	1380											▲	▲	▲	▲	▲		
Q132	3 mil film	AO	Coloured by grit	UV																			
Q135	3 mil film	AO White	Coloured by grit	UV	Ophthalmic markets																		
Q351R	5 mil film	AO White	Coloured by grit	New high performance resin	Rough Backcoat																		
Q351S	5 mil film	AO White	Coloured by grit	New high performance resin	Smooth Backcoat																		
Q361	3 mil film	AO WHITE	Coloured by grit	UV	Ophthalmic markets																		
L12F3	3 mil film	Ao White	Coloured by grit		Lapping film	330																	
L41F3	3 mil film	SiC	Gray		Lapping film	330																	
L61F3	3 mil film	Diamond	Coloured by grit		Lapping film	330																	
L67F3	3 mil film	Diamond	Coloured by grit		Lapping film	330																	
M631	3 mil film	Nanozyte Diamond	Tan		Lapping film Nanozyte																		



GRIT SIZE																SHAPE AVAILABILITY						
280	240	220	180	150	120	100	80	60	50	40	36	30	24	20	16	PRODUCT CODE	BELTS W ≤ 400mm	BELTS W > 400mm	DISCS	STD SHEETS	OTHER SHEETS	ROLLS
					▲		▲	▲								G156F						
																A277		BWD				FW
			▲		▲		▲				▲					G131F						FW
																G133F						
		▲		▲	▲	▲	▲	▲	▲	▲	▲					H216F						
																H259		BWD				
	▲		▲	▲	▲	▲	▲	▲	▲	▲	▲					H231						Self-Grip* in FW
	▲		▲	▲	▲	▲	▲	▲	▲	▲	▲					H235						
			▲	▲		▲	▲	▲	▲	▲	▲					H425		BWD				FW
				▲		▲	▲	▲		▲						H835F Blue Fire						FW
																H822						FW

\* To help better describe the abrasive fixing system we have changed the name from 'NorGrip' to 'Self-Grip'.

GRIT SIZE																SHAPE AVAILABILITY									
22µ-800	25µ-600	30µ-500	35µ-400	40µ	45µ	46µ-320	50µ	53µ-280	59µ-240	60µ-220	73µ-180	75µ	80µ	90µ-150	100µ	110µ-120	180µ-80	200µ	PRODUCT CODE	BELTS W ≤ 400mm	BELTS W > 400mm	DISCS	STD SHEETS	OTHER SHEETS	ROLLS
																			Q255						
																			Q175 Pure Ice						
	▲	▲	▲	▲	▲	▲	▲		▲	▲	▲	▲	▲	▲		▲	▲		Q275						
																			Q135						
																			Q135						
																			Q351R						
																			Q351S						
																			Q361						
																			L12F3						
																			L41F3						Rolls 101 & 203mm
																			L61F3						Rolls 101 & 203mm
																			L67F3						Rolls 101 & 203mm
																			M631						

COATED ABRASIVES & BEARTEX

BONDED ABRASIVES

SUPER ABRASIVES

DIAMOND TOOLS

CLEANING, POLISHING & MASKING

PERSONAL PROTECTION EQUIPMENT

TECHNICAL INFORMATION



## FIBRE AND SCREENBACK PRODUCTS

PRODUCT CODE	BACKING	ABRASIVE	PRODUCT COLOUR	BOND	COMMENTS	USEABLE WIDTH (mm)	GRIT SIZE																
							NO GRIT	5µ-3000	8µ-2500	10µ-2000	12µ-1500	16µ-1200	1000	800	600	500	400	360	320				
F100	0,6/0,8	AO	Maroon	PF/PF	P16 to P50 in 0,8																		
F293	0,8	AO	Maroon	PF/PF																			
F425	0,8	SIC	Black	PF/PF																			
F827	0,8	NZ/AO	Blue	PF/PF																			
F975	0,8	SG	Green	PF/PF																			
F996 Norton Quantum	0,8	SG	Red	PF/PF	Supersize																		
Q421	Grid	SIC	Black	PF/PF	Screenbak	1150																	
Q263	Grid (fine)	AO	Green	PF/PF	Screenbak																		

## COTTON CLOTH PRODUCTS

PRODUCT CODE	BACKING	ABRASIVE	PRODUCT COLOUR	BOND	COMMENTS	USEABLE WIDTH (mm)	GRIT SIZE																
							NO GRIT	5µ-3000	8µ-2500	10µ-2000	12µ-1500	16µ-1200	1000	800	600	500	400	360	320				
K625	J light	Emery	Black	G/G	'Emery cloth'	Stock sheets																	
R202	J cotton	AO	Maroon	PF/PF		1400																	
R207	X cotton	AO	Maroon	PF/PF	Flap wheel only	1500																	
R212	J cotton	AO	Black	UF	Handy rolls	1400																	
R222	J cotton	AO	Maroon	PF/PF	Handy rolls	1150																	
R230	X cotton	AO	Maroon	PF/PF		1500																	
R265	X cotton	AO	Maroon	PF/PF	Flap Disc	1500																	
R287	J cotton	AO	Maroon	PF/PF		1400																	
R309	JJ cotton	AO	Red/Brown	PF/PF		1400																	
R376	JJ cotton	AO	Green	PF/PF	Special stainless steel	1400																	
R423	J cotton	Aggreg SiC	Black	PF/PF	Closed coat	1400																	
R426	JJ cotton	SiC	Black	PF/PF	Special brass and non ferrous metals	1400																	
R427	X cotton	SiC	Black	PF/PF		1430																	
R822	X cotton	NZ/AO	Blue	PF/PF		1500																	
R842	X cotton	NZ/AO	Blue	PF/PF	Flap Disc	1500																	
R828	X polycotton	NZ	Blue	PF/PF	Flap Disc	1500																	
R82A	X cotton	AO/NZ	Blue	PF/PF	Belt/Flap disc	1500																	
R82B	X cotton	AO/NZ	Blue	PF/PF	Flap Disc	1500																	
R926	X cotton	SG/AO	Red	PF/PF	Supersize	1500																	
R928	PolyCotton	SG	Pink	PF/PF	Flap Disc	1500																	
R946	J PolyCotton	SG/AO	Red	PF/PF	Supersize + Superflexible	1500																	
RX22	X cotton	Delta/AO	Green	PF/PF		1500																	

GRIT SIZE																SHAPE AVAILABILITY							
280	240	220	180	150	120	100	80	60	50	40	36	30	24	20	16	PRODUCT CODE	BELTS W ≤ 400mm	BELTS W > 400mm	DISCS	STD SHEETS	OTHER SHEETS	ROLLS	
																F100							
																F293							
																F425							
																F827							
																F975							
																F996 Norton Quantum							
																Q421				Stock			FW
																Q263							

GRIT SIZE																SHAPE AVAILABILITY							
280	240	220	180	150	120	100	80	60	50	40	36	30	24	20	16	PRODUCT CODE	BELTS W ≤ 400mm	BELTS W > 400mm	DISCS	STD SHEETS	OTHER SHEETS	ROLLS	
			Very Fine	Fine	Medium	Coarse	Very Coarse									K625				Stock			
																R202							
																R207							FW
																R212				Stock			FW
																R222	P600			Stock			FW
																R230		BWD					
																R265		BWD					
																R287							
																R309							
																R376							
																R423							FW
																R426							FW
																R427		BWD					
																R822		BWD					FW
																R842							FW
																R828							
																R82A	DIY						
																R82B							
																R926							
																R928							
																R946							
																RX22							FW

COATED  
ABRASIVES  
& BEARTEX

BONDED  
ABRASIVES

SUPER  
ABRASIVES

DIAMOND  
TOOLS

CLEANING,  
POLISHING  
& MASKING

PERSONAL  
PROTECTION  
EQUIPMENT

TECHNICAL  
INFORMATION

## POLYESTER CLOTH PRODUCTS (EXCEPT CHIPBOARD)

PRODUCT CODE	BACKING	ABRASIVE	PRODUCT COLOUR	BOND	COMMENTS	USEABLE WIDTH (mm)	GRIT SIZE																			
							NO GRIT	5 $\mu$ -3000	8 $\mu$ -2500	10 $\mu$ -2000	12 $\mu$ -1500	1100	1000	800	600	500	400	360	320							
R293	X/Y poly	AO	Maroon	PF/PF	P24 to P60 with 10% SG	1500																				
R270	Y poly	Aggreg AO	Maroon	PF/PF	Closed coat	1400																				
R275	Y poly	Aggreg AO	Maroon	PF/PF	Open coat	1400																				
R279	Y poly	Aggreg AO	Maroon		Closed coat stong bond	1400																				
R445	X/Y poly	SiC	Black	PF/PF		1400																				
R473	Y poly	Aggreg SiC	Maroon	PF/PF		1400																				
R817	Y poly	NZ	Blue	PF/PF	Open coat	1500																				
R872	Y/X Poly	New NZ	Blue	PF/PF	Blue Force - Open coat	1500																				
R874	YY/Y Poly	New NZ	Blue	PF/PF	Blue Force	1500																				
R876	YY/Y Poly	New NZ	Blue	PF/PF	Blue Force - Supersize	1500																				
R929	X poly	New SG/AO	Green	PF/PF		1500																				
R984	Y poly	SG/AO	Maroon	PF/PF		1500																				
RX84	Y poly	Delta/AO	Green	PF/PF		1500																				
R976P	Y poly	SG/AO	Pink	PF/PF	Supersize	1500																				
R976 Red-X	Y poly	SG/AO	Red	PF/PF	Supersize	1500																				
RX66	Y poly	Delta/AO	Green	PF/PF	Supersize	1500																				
R996 Viking	YY/Y Poly	New SG	Red	PF/PF	Flap Disc - Supersize	1500																				
W441	X cotton	SiC/Cork	Black	PF/PF	Waterproof	1400																				
W445	Y poly	Cork	Beige	PF/PF	Cork polishing	1320																				
W448	Y poly	SiC/Cork	Black	PF/PF	Waterproof Cork polishing																					

## PRODUCTS FOR CHIPBOARD AND OTHER COMBINATIONS

PRODUCT CODE	BACKING	ABRASIVE	PRODUCT COLOUR	BOND	COMMENTS	USEABLE WIDTH (mm)	GRIT SIZE																			
							NO GRIT	5 $\mu$ -3000	8 $\mu$ -2500	10 $\mu$ -2000	12 $\mu$ -1500	16 $\mu$ -1200	1000	800	600	500	400	360	320							
R496	YY poly	SiC	Black	PF/PF	Antistatic	1440																				
S88XL	YY poly	SiC	Black	PF/PF		1400																				
S413	Light combi	SiC	Black	PF/G	Open coat	1430																				
S422	Light combi	SiC	Black	PF/G	Closed coat	1430																				
S496	Heavy combi	SiC	Black	PF/PF	Antistatic	1440																				
H496	400g paper	SiC	Black	PF/PF	Antistatic	1440																				

GRIT SIZE																SHAPE AVAILABILITY								
	280	240	220	180	150	120	100	80	60	50	40	36	30	24	20	16	PRODUCT CODE	BELTS W <sub>≤</sub> 400mm	BELTS W <sub>&gt;</sub> 400mm	DISCS	STD SHEETS	OTHER SHEETS	ROLLS	
																	R293							
																	R270							FW
																	R275							FW
																	R279							
																	R445							
																	R473							FW
																	R817							
																	R872							
																	R874							
																	R876							
																	R929							
																	R984							
																	RX84							
																	R976P							
																	R976 Red-X							
																	RX66							
																	R996 Viking							
																	W441							
																	W445							
																	W448							FW

COATED ABRASIVES & BEARTEX

BONDED ABRASIVES

SUPER ABRASIVES

DIAMOND TOOLS

CLEANING, POLISHING & MASKING

PERSONAL PROTECTION EQUIPMENT

TECHNICAL INFORMATION

GRIT SIZE																SHAPE AVAILABILITY								
	280	240	220	180	150	120	100	80	60	50	40	36	30	24	20	16	PRODUCT CODE	BELTS W <sub>≤</sub> 400mm	BELTS W <sub>&gt;</sub> 400mm	DISCS	STD SHEETS	OTHER SHEETS	ROLLS	
																	R496		BSG					FW
																	S88XL		BWD					FW
														▲		▲	S413		BSG					Self-Grip <sup>†</sup> in FW
																	S422		BWD					
																	S496		BSG					FW
																	H496							FW

<sup>†</sup> To help better describe the abrasive fixing system we have changed the name from 'NorGrip' to 'Self-Grip'.



## NORaX PRODUCTS

PRODUCT CODE	BACKING	ABRASIVE	PRODUCT COLOUR	BOND	COMMENTS	USEABLE WIDTH (mm)	GRIT SIZE											
							NO GRIT	5µ-3000	8µ-2500	10µ-2000	12µ-1500	14µ-1200	1000	800	600	500	400	360
U243	J Coton Rayon	A/O	Grey	UV	NORaX fine tri-hellcal	600						X16	X22		X30	X45		
U234	XF cotton	A/O	Brown / White	UV	NORaX quad	600										X45		
U254	XF cotton	A/O	Brown / White	UV	NORaX pyramid	600		X5				X16	X22		X30	X45		
U264	XF cotton	A/O	Brown / White	UV	NORaX tri-helical	600						X16	X22		X30	X45		
U366	Y poly	AO	Grey	UV	NORaX tri-helical	600		X5				X16	X22		X30	X45		
U336	Y poly	AO	White	UV	NORaX quad	600						X16	X22		X30	X45		
U464	XF cotton	SIC	Green	UV	NORaX tri-helical	600												
U466	Y Poly	SIC	Green	UV	NORaX tri-helical	600												
U936	Y poly	SG	Grey	UV	NORaX quad	600						X16			X30	X45		

## SCM CAP CODE OVERVIEW: AVAILABLE IN BELTS AND DISCS

POPULAR FORM	UNIVERSAL GRADE	MINERAL	NORTON DESCRIPTION / GRADE	FORMER NORTON MCC	NEW RAPID PREP		
					RAPIDPREP AO MCC	VORTEX RAPIDPREP MCC	
Belts/ Discs	Extra Coarse	A0	DSB extra coarse	S2112	S2108	S2103	RapidPrep LF (SCRIM BACK)
	Heavy Medium	A0	DSB heavy medium	S2312			
Discs	Coarse	A0	DSB coarse	S2211	S2208	S2203	
	Medium	A0	DSB medium	S2311	S2308	S2303	
	Fine	A0			S2408	S2403	
	Very Fine	A0	DSB very fine	S2511	S2508	S2503	
Belts (low Stretch)	Coarse XS LS	A0	DSJ Coarse	S2213	S2228	S2223	RapidPrep RF
	Medium XS LS	A0	DSJ medium	S2313	S2328	S2323	
	Fine	A0	Fine		S2428	S2423	
	Very Fine XS LS	A0	DSJ very fine	S2513	S2528	S2523	
	Super Fine XS	SiC	DSJ Super fine	S4713			
Long Belts (flexible e.g. 50x2000mm)	Ultra Fine	SiC	SiC Ultra fine	S4601			
	Extra Coarse A	A0	Superflex Extra Coarse	S2116			
	Coarse A	A0	Superflex Coarse	S2216		S2223	
	Medium A	A0	Superflex Medium	S2316		S2323	
	Fine A	A0	Superflex Fine	S2415		S2423	
File Belts (small e.g. 12x457mm)	Very Fine A	A0	Superflex Very Fine	S2516		S2523	
	Super Fine S	SiC					
	Coarse A	A0	DSX Coarse	S2218	S2238	S2253	RapidPrep XF
	Medium A	A0	DSX medium	S2318	S2338	S2353	
Fine A	A0	DSX fine	S2418	S2438	S2453		
Very Fine A	A0	DSX very fine	S2518	S2538	S2553		
Heavy Duty Belts/Discs	Coarse	A0		S2215			
	Medium	A0		S2315			

GRIT SIZE																SHAPE AVAILABILITY						
280	240	220	180	150	120	100	80	60	50	40	36	30	24	20	16	PRODUCT CODE	BELTS W <sub>≤</sub> 400mm	BELTS W <sub>&gt;</sub> 400mm	DISCS	STD SHEETS	OTHER SHEETS	ROLLS
	X65		X80													U243						
	X65		X80		X100											U234						
	X65		X80		X100											U254						
	X65		X80		X100		X200									U264						
	X65				X100											U366		BWD				
	X65															U336						
	X70		X90		X110											U464						
	X70		X90		X110		X210									U466						
	X65				X100		X200									U936						

COATED ABRASIVES & BEARTEX

BONDED ABRASIVES

SUPER ABRASIVES

DIAMOND TOOLS

CLEANING, POLISHING & MASKING

PERSONAL PROTECTION EQUIPMENT

TECHNICAL INFORMATION

FLAT STOCK: AVAILABLE IN HANDPADS, ROLLS AND SHEETS.

Cap code	F2302/ F2316 (Med A HD)	F2300	F2401	F2520/ F2529	F2504	F2510	F4300	F4804/ F4807/ F4605	F2801/ F2829	F0001
Grade	Extra Cut	Medium	Fine	Very Fine	Very Fine (long life)	Gen. Purpose Clean & Scour	Medium (SiC)	Ultra Fine	Micro Fine	White cleaning
Mineral	Aluminium Oxide	Aluminium Oxide	Aluminium Oxide	Aluminium Oxide	Aluminium Oxide	Alumina Silicate	Silicon Carbide	Silicon Carbide	Micro Fine	None
Target substrate	Stainless Steel	Metals & ceramics	Wood & plastics	General Purpose	General Purpose	Metals & Plastics	Stainless Steel	General Purpose	Precious Metals, Varnished Wood, Car Body Work	All Substrates

# INTRODUCTION TO BEARTEX NON-WOVEN PRODUCTS

BearTex consists of a backing in “non-woven” nylon fibers evenly impregnated with abrasive granules through the binding action of synthetic resins. This structure forms a “three-dimensional” abrasive material. Since this product was created as a finishing tool for operations where no material need be removed, it is particularly suitable for buffing-up purposes or to reduce the roughness of a surface: BearTex begins to act when other abrasive tools have terminated their work. In all those situations where a buffing, cleaning or finishing operation is required, the BearTex product is decidedly a must.

## UNDERSTANDING THE NON-WOVEN CAP CODE SYSTEM

RapidFinish Convolute  
S/C (Silicon Carbide)  
Fine

C

4

4

15

MARKETING PRODUCT NAME	MARKETING CAP CODE FAMILY	TYPE OF MATERIAL	GRAIN	GRADE	INTERNAL DIFFERENTIATION
Bear-Tex	Flat Stock	F	0- No Grain	0- No Grit	Consecutive numbers used for internal differentiation
Rapid Blend-Unified	Utilized/Unified	U	1- A/O White	1- Extra Coarse	
Rapid Strip	Rapid Strip	R	2- A/O Brown	2- Coarse	
Rapid Prep-Surface Conditioning	SCM Surface Conditioning Material / Blending	S	4- S/C	3- Med.	
Rapid Finish-Convolute	Convolute	C	5- Garnet	4- Fine	
Floor pads	Floor Maintenance	JF	7- Diamond	5- Very Fine	
			9- Ceramic	6- Ultra Fine	
				7- Super Fine	
				8- Micro Fine	

USED WET OR DRY, BEARTEX PRODUCTS OFFER THE FOLLOWING ADVANTAGES:

- A predictably consistent, uniform finish
- Minimum smearing and discolouration of the work-piece as heat is dissipated through the open mesh of the product
- Increased productivity through savings in time
- Ability to automate operations
- Reduced operator training
- Less maintenance required
- Greater safety than other methods
- Conformability to irregular surfaces

These advantages make BearTex products an excellent alternative to bristle brushes, set-up wheels, greaseless compounds, and steel wool. Operators quickly learn the techniques of using BearTex products to produce eye catching finishes.

BEARTEX PRODUCTS CAN BE USED ON A WIDE VARIETY OF SURFACES

- Aluminium
- Chromium
- Tantalum
- Fibreglass
- Brass
- Stainless Steel
- Ceramics
- Wood
- Copper
- Zinc
- Glass
- Plywood
- Nickel
- Titanium
- Plastic

APPLICATIONS INCLUDE

- Deburring
- Blending
- Defuzzing plywood
- Decorative finishes
- Cleaning
- Polishing
- Dulling laminates
- Scrubbing
- Highlighting
- Imparting satin
- Scouring
- Deflashing plastics
- Removing raised wood fibres

### NEW BEARTEX NON-WOVEN WEBSITE

Scan the QR code or visit website using the web address below.

[www.nortonbeartex.com](http://www.nortonbeartex.com)



WEBSITE LINK

# APPLICATION / GRIT RECOMMENDATION

COARSE (GRINDING)						FINE (FINISHING)					
Grit	24	30	36	40	50	60	80	100	120	150-180	180-320 +
Cutting-off & grinding wheels	Cutting-off										
	Heavy Duty Grinding										
Coated abrasives	Stock Removal										
		Blending & Refining									
			Deburring								
				Surface Preparation & Cleaning							
						Finishing					
BearTex						Coarse		Medium	Very Fine		

## ABRASIVE TYPES

**BEARTEX** products are manufactured utilising either silicon carbide or aluminium oxide abrasive grain. These are the same high quality abrasives used in Norton’s world famous coated abrasive products.

**SILICON CARBIDE** is a hard, sharp, brittle abrasive grain which tends to break down under pressure. Therefore silicon carbide items are sharper, tend to cut faster and produce finer scratch patterns on most surfaces.

**ALUMINIUM OXIDE** is a tough, blocky abrasive which does not tend to break down. Aluminium oxide is more durable than silicon carbide and tends to last longer, produce less discolouration on aluminium, and be more aggressive on certain applications such as hardened steel parts.

### GRIT SIZE

The ‘grit’ refers to the particle size of the abrasive grain that is impregnated into the nylon web during manufacture.

Use of large particles result in a Beartex product that acts more aggressively and produces a coarse surface finish. Small size particles result in a Beartex product that produces fine surface finishes.

### DENSITY

The ‘density’ refers to the number of fibres which have been compressed onto the nylon web material. Most Beartex products are made in a single density designed to meet the requirements of the intended application. However, several wheel items offer two densities to provide a broader range of finishing results.

Under identical conditions, ‘hard’ density wheels cut faster, last longer and produce finer finishes than medium density wheels. ‘medium’ density wheels offer greater conformability and less tendency to load the workface.

### BOND TYPES

Waterproof resins are used throughout the manufacture of Beartex web material to bond the nylon fibres together and to firmly anchor the abrasive grains throughout the web.

COATED ABRASIVES & BEARTEX

BONDED ABRASIVES

SUPER ABRASIVES

DIAMOND TOOLS

CLEANING, POLISHING & MASKING

PERSONAL PROTECTION EQUIPMENT

TECHNICAL INFORMATION





# 089-116 DISCS FOR ANGLE GRINDERS



90 Fibre Discs  
94 Flap Discs

102 Semi Flexible Discs  
105 Blending

113 Stripping & Cleaning  
115 Finishing & Polishing

COATED  
ABRASIVES  
& BEARTEX

BONDED  
ABRASIVES

SUPER  
ABRASIVES

DIAMOND  
TOOLS

CLEANING,  
POLISHING  
& MASKING

PERSONAL  
PROTECTION  
EQUIPMENT

TECHNICAL  
INFORMATION

# FIBRE DISCS

From rapid weld grinding to blending and finishing, Norton has a complete range of high performance fibre discs available in premium performance Norton SG ceramic aluminium oxide, zirconia alumina, and aluminium oxide abrasives. All fibre discs in the Norton range feature a full resin bond system with heavy duty fibre backing for increased strength, durability and tear resistance.

## APPLICATIONS & MARKETS

- Material removal
- Weld grinding & blending
- Light deburring & finishing
- Car manufacturing
- Metal fabrication
- Welding & foundry markets
- Transport markets



COATED  
ABRASIVES  
& BEARTEX

BONDED  
ABRASIVES

SUPER  
ABRASIVES

DIAMOND  
TOOLS

CLEANING,  
POLISHING  
& MASKING

PERSONAL  
PROTECTION  
EQUIPMENT

TECHNICAL  
INFORMATION

## NORTON QUANTUM F996



FERR.  
& NON  
FERR.

### FEATURES

- New SG ceramic abrasives
- Extremely high density of abrasive
- 0,84/0,8mm improved fibre backing
- Supersize with a high % of active fillers

BEST +++++

INNOVATION



### BENEFITS

- Exceptionally high performance
- High material removal even at low pressure
- Generates an excellent surface finish
- Exceptionally long life
- Resists loading & has low heat generation

## GREENLYTE F975



FERR.  
& NON  
FERR.

### FEATURES

- SG ceramic abrasive
- 0,8mm high strength fibre backing

BEST +++++



### BENEFITS

- Fastest cut rate
- Suitable for metal grinding, shaping, blending, edge breaking & weld removal
- Resistant to high pressure
- Cool cut

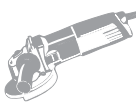

## NORZON F827

BETTER ++++



### FEATURES

- Norzon abrasive
- 0,8mm fibre backing

*NorZon*

### BENEFITS

- General purpose
- Ideal for grinding, shaping, blending, edge breaking & weld
- High & regular cut rate
- Good for high metal removal in short time
- Excellent price-performance ratio

## F293

GOOD +++



### FEATURES

- Aluminium oxide abrasive
- 0,8mm fibre backing

### BENEFITS

- General purpose
- General metal grinding, shaping & polishing
- Good cut rate
- Weld removal

## F100

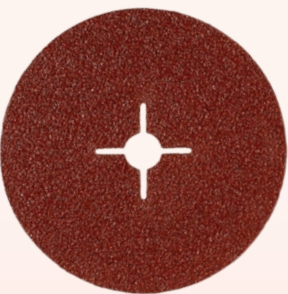

### FEATURES

- Tough versatile aluminium oxide abrasive
- 0,8/0,6mm fibre backing
- Grinding additives

### BENEFITS

- Versatile product (ideal for steel and metal alloys)
- Longer product life
- Good performance on steel

## PRODUCT SELECTION GUIDE

MATERIALS / APPLICATIONS	HIGHLY RECOMMENDED	RECOMMENDED	SUITABLE
Stainless Steel/Heat Sensitive Alloys	F996	F827	F293
Carbon Steel/Weld/Ferrous metal	F975	F827	F293
Non-Ferrous Metal/Brass/Aluminium		F827	F100
Stone		F425*	F100

\* Made-to-order

COATED  
ABRASIVES  
& BEARTEX

BONDED  
ABRASIVES

SUPER  
ABRASIVES

DIAMOND  
TOOLS



CLEANING,  
POLISHING  
& MASKING

PERSONAL  
PROTECTION  
EQUIPMENT

TECHNICAL  
INFORMATION



# STANDARD

DIM DIAxH(mm)	GRIT	PK QTY	NORTON QUANTUM	GREENLYTE	NORZON			
			F996	F975	F827	F293	F100	
			BEST INNOVATION	BEST	BETTER	GOOD		
115x22 	16	25					66623385735	
	24	25			69957360048	63642547861	66623385738	
	36	25		63642568819	63642539615	63642535056	66623385741	
	36	100	66623327494					
	40	25					66623385745	
	50	25		63642568820	69957360053	07660705216	66623385747	
	50	100	66623327496					
	60	25		63642568821	63642539616	63642536900	66623385748	
	60	100	66623327497					
	80	25		63642568822	63642539617	07660705214	66623385750	
	80	100	66623327499					
	100	25				07660705213	66623385751	
	120	25			63642533055	07660705212	66623385757	
	120	100	66623327500					
125x22 	16	25					66623385761	
	24	25			63642539619	63642547907	66623385764	
	36	25		63642568823	63642536483	63642547906	66623385768	
	36	100	66623327501					
	40	25					66623385770	
	50	25		63642568824	63642539620	63642547905	66623385773	
	50	100	66623327502					
	60	25		63642568825	69957360057	63642547904	66623385775	
	60	100	66623327503					
	80	25		63642568826	63642539622	63642547903	66623385776	
	80	100	66623327504					
	100	25			63642536484	63642547902	66623385778	
	120	25			63642533056	63642547901	66623385779	
	120	100	66623327505					
180x22 	16	25				63642533109	66623385755	
	24	25			63642533062	63642533108	66623385758	
	36	25		63642568827	63642533063	63642533107	66623385760	
	36	100	66623327506					
	40	25					66623385752	
	50	25		63642568828	63642533064	63642535057	66623385793	
	50	100	66623327507					
	60	25		63642568830	63642533065	63642533105	66623385749	
	60	100	66623327508					
	80	25			63642533066	63642533104	66623385746	
	80	100	66623327509					
	100	25				63642533103	66623385744	
	120	25			63642533068	63642533102	66623385739	
	120	100	66623327510					

COATED  
ABRASIVES  
& BEARTEX

BONDED  
ABRASIVES

SUPER  
ABRASIVES

DIAMOND  
TOOLS

CLEANING,  
POLISHING  
& MASKING

PERSONAL  
PROTECTION  
EQUIPMENT

TECHNICAL  
INFORMATION

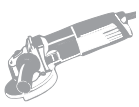

## MOULDED

### GREENLYTE F975

DIM DIAxH(mm)	GRIT	PK QTY	BEST
180x22 	36	100	63642568832
	50	100	63642568833
	60	100	63642568834
	80	100	63642568835

## BACK-UP PADS

DIA (mm)	DENSITY	ATTACHMENT	PK QTY	ART. NO.
<b>AIRCOOL</b>				
115	Hard	M14	1	69957382821
125	Hard	M14	1	69957382823
178	Hard	M14	1	69957382824
	Hard	5/8	1	63642588243
<b>NYLON FIBREGLASS REINFORCED BACK-UP PADS</b>				
115	Hard	M14	5	66623376727
125	Hard	M14	5	66623376821
	Hard	5/8	5	66623377068
180	Hard	M14	5	66623376822
	Hard	5/8	5	66623377069
<b>NYLON</b>				
115	Hard	M14	5	69957382828
	Medium	M14	5	69957382825
125	Hard	M14	5	69957382829
	Medium	5/8	5	63642588341
	Medium	M14	5	69957382826
178	Hard	M14	5	69957382830
	Medium	5/8	5	63642588345
	Medium	M14	5	69957382827

**Dimensions Key:** DIM = Dimensions, DIA = Diameter, H = Hole



### MAXIMUM OPERATING SPEED

DIA (mm)	100	115	125	150	180
MOS (m/s)	80	80	80	80	80
MAX RPM	5300	13300	12300	10200	8600

The maximum peripheral operating speed of a fibre disc is 80m/s.  
This is communicated on the box label.

COATED  
ABRASIVES  
& BEARTEX

BONDED  
ABRASIVES

SUPER  
ABRASIVES

DIAMOND  
TOOLS

CLEANING,  
POLISHING  
& MASKING

PERSONAL  
PROTECTION  
EQUIPMENT

TECHNICAL  
INFORMATION

# FLAP DISCS

Norton flap discs are engineered for multiple applications including light stock removal, blending and finishing, meaning they can help reduce processing times and lower costs. Flap discs have a fast cut and provide a better finish than fibre while having the added benefit of a longer life.

## APPLICATIONS & MARKETS

- Stock removal
- Edge chamfering
- Deburring
- Rust/paint removal
- Cleaning & finishing
- Grinding & blending welds



COATED  
ABRASIVES  
& BEARTEX

BONDED  
ABRASIVES

SUPER  
ABRASIVES

DIAMOND  
TOOLS

CLEANING,  
POLISHING  
& MASKING

PERSONAL  
PROTECTION  
EQUIPMENT

TECHNICAL  
INFORMATION

BEST +++++

INNOVATION

## NEW NORTON QUANTUM

MAXIMUM PERFORMANCE R928



### FEATURES

- New ceramic grain formulation
- Polycotton cloth
- Heavy abrasive density vs standard ceramic product
- Supersize treatment
- Competitive pricing
- New PINK flaps

### BENEFITS

- High and quick cut rate
- Heavy stock removal
- No Glazing
- Regeneration of grain optimised
- Good resistance
- Comfortable to use, less vibrations
- Thicker product
- Appears a high quality product
- Longer life time
- Boosts cut rate
- Cooling agent
- No burn marks
- Meets market need
- Differentiate vs competition
- Easy to identify on merchandising

## OMEGA HIGH DENSITY R828



**OMEGA**

### FEATURES

- 100% high performance Norton zirconia alumina grain
- Polycotton backing cloth
- Heavy duty configuration

### BENEFITS

- Fast and consistent cut
- Best for heavy duty application
- Long lasting product

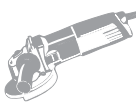

## OMEGA R828

BEST +++++



**OMEGA**

### FEATURES

- 100% high performance Norton zirconia alumina abrasive grain
- Specifically engineered heavy cloth optimized for controlled wear characteristics
- Durable innovative bond system

### BENEFITS

- Fast and consistent cut
- Best for mid/heavy duty application
- Increased life time and cut renewal
- Low vibrations

COATED  
ABRASIVES  
& BEARTEX

BONDED  
ABRASIVES

## TWINSTAR QUICK CUT RX22/R822



**TWINSTAR**  
QUICK CUT

### FEATURES

- Premium SG ceramic aluminium oxide & Norton zirconia alumina abrasive blend
- High density disc with extra-large flaps
- Heavy cotton cloth
- Reinforced plastic backing

### BENEFITS

- Aggressive stock removal with less pressure, giving a cooler cut
- Achieves a much longer life due to the high density of flaps

SUPER  
ABRASIVES

DIAMOND  
TOOLS

## NORSTAR QUICK CUT RX22/R822



**NORSTAR**  
QUICK CUT

### FEATURES

- Premium SG ceramic aluminium oxide & Norton zirconia alumina abrasive blend
- Heavy cotton cloth
- High content of active filler
- Fiberglass backing

### BENEFITS

- Aggressive stock removal with less pressure

CLEANING,  
POLISHING  
& MASKING

PERSONAL  
PROTECTION  
EQUIPMENT

TECHNICAL  
INFORMATION



## OIL &amp; GAS R828

BETTER ++++

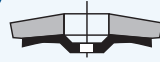

OIL &amp; GAS

## FEATURES

- 100% high performance Norton zirconia grain
- Specially engineered heavy polycotton backing cloth
- Heavy duty configuration

## BENEFITS

- Cut faster
- Longer lifetime
- Ideal for stainless steel medium pressure applications
- Excellent finish
- Ideal for land based and off-shore rig maintenance operations.

## VULCAN R842



VULCAN

## FEATURES

- Self-sharpening zirconium abrasive grain
- New resin bond system
- New thicker cotton backing

## BENEFITS

- Aggressive cutting action
- Faster material removal
- Increased wear resistance than standard discs
- Long product life
- Ideal for all low and medium pressure

## VULCAN R265



VULCAN

## FEATURES

- Durable aluminum oxide abrasive grain
- Heavy cotton cloth
- Double flap disc construction
- Plastic backing

## BENEFITS

- Fast initial cut rate especially on carbon steel

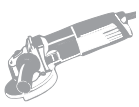

## FLEXI DISCS

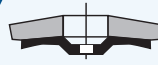

**FLEXIFLAP**

### FEATURES

- Premium Norzon grain
- Flexible cloth backing
- Angular flap disc construction
- Available in grit range 40, 60, 80

### BENEFITS

- Remove material quickly & effectively
- Adapt to contours & improved finish
- Increased flexibility in use

## STARLINE R82A/B

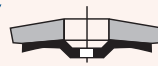

**GOOD +++**

**Starline**

### FEATURES

- Blend of quality aluminium oxide and zirconium grain
- Cotton cloth
- Low vibration levels

### BENEFITS

- Fast cutting and optimal material removal rate
- Comfortable working
- Consistent performance for improved part quality
- Ideal for low and medium pressure applications
- Best performance for value

COATED  
ABRASIVES  
& BEARTEX

BONDED  
ABRASIVES

SUPER  
ABRASIVES

DIAMOND  
TOOLS

CLEANING,  
POLISHING  
& MASKING

PERSONAL  
PROTECTION  
EQUIPMENT

TECHNICAL  
INFORMATION



### SPEC CHECK

For tougher, more aggressive applications where more power is needed, Omega offers a range of discs with higher density and stronger flaps for extreme material removal and extra long life.

## PRODUCT SELECTION GUIDE

MATERIAL	INNOVATION	BEST	BETTER	GOOD
Heat sensitive Alloys / High strength steel / Hard to grind metals	Norton Quantum	Norstar / Twinstar / Omega		
Stainless steel	Norton Quantum	Norstar / Twinstar / Omega	Vulcan	
Carbon steel		Norstar / Twinstar / Omega	Vulcan	Starline
Aluminium / Cast iron / Bronze / Copper / Composite			Vulcan	Starline
Wood / Paint				Starline
<b>THIN WHEEL EQUIVALENT QUALITY</b>	Norton Quantum	Omega	Vulcan	
<b>MACHINE</b>	High power (more than 1000 Watts)		Low power (less than 1000 Watts)	



### SPEC CHECK

- Conical flap discs are designed to be used at an angle of 15-25°
- For an equivalent finish, always use a flap disc one grit size coarser than with a fibre disc

### MOQ for MTO

- 115mm - 1200 pcs
- 125mm - 960 pcs
- 180mm - 360 pcs

COATED  
ABRASIVES  
& BEARTEX

BONDED  
ABRASIVES

SUPER  
ABRASIVES

DIAMOND  
TOOLS

CLEANING,  
POLISHING  
& MASKING

PERSONAL  
PROTECTION  
EQUIPMENT

TECHNICAL  
INFORMATION

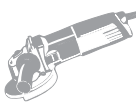

**FIBREGLASS BACKED**

		<b>NORTON QUANTUM</b>		<b>OMEGA HD</b>	<b>OMEGA</b>	<b>NORSTAR</b>
		R928		R828	R828	RX22/R822
				BEST INNOVATION		BEST
DIM DIAxH(mm)	GRIT	PK QTY				
 Conical						
115x22	40	10	66261143333		63642502475	63642534667
	60	10	66261143336		63642502476	63642534668
	80	10	66261143337		63642502477	63642534669
	120	10	66261143338		63642502478	63642534670
125x22	40	10	66261143339	63642502463	63642502480	63642563571
	60	10	66261143340	63642502464	63642502483	63642568611
	80	10	66261143341	63642502465	63642502484	63642549404
	120	10	66261143343		63642502485	63642550474
150x22	40	10			63642502490	
	60	10			63642502491	
	80	10			63642502493	
	120	10			63642502494	
180x22	40	10	66261143344		63642502486	69957336664
	60	10	66261143345		63642502487	63642549405
	80	10	66261143346		63642502488	63642549406
	80	10	66261143347			

COATED  
ABRASIVES  
& BEARTEX

BONDED  
ABRASIVES

SUPER  
ABRASIVES

**FIBREGLASS BACKED**

		<b>OIL &amp; GAS</b>		<b>VULCAN</b>	<b>VULCAN</b>	<b>STARLINE</b>
		R828		R842	R265	R82A/B
				BETTER		GOOD
DIM DIAxH(mm)	GRIT	PK QTY				
 Conical						
115x22	40	10		63642502311	63642589240	
	60	10		63642502312	63642589241	
	80	10		63642502313	63642589242	
	120	10		63642502314	63642589243	
125x22	40	10	77696084938	63642502315	63642589253	66254492271
	60	10	77696084943	63642502317	63642589254	66254492272
	80	10		63642502318	63642589255	66254492273
	120	10		63642502326	63642589256	66254492274
150x22	40	10		63642502327		
	60	10		63642502328		
	80	10		63642502329		
	120	10		63642502330		
180x22	40	10		63642502341		
	60	10		63642502343		
	80	10		63642502345		
	120	10		63642502347		

DIAMOND  
TOOLS

CLEANING,  
POLISHING  
& MASKING

PERSONAL  
PROTECTION  
EQUIPMENT

TECHNICAL  
INFORMATION

**Dimensions Key:** DIM = Dimensions, DIA = Diameter, H = Hole



## FIBREGLASS BACKED

**NORTON QUANTUM**  
R928

**OMEGA**  
R828

**NORSTAR**  
RX22/R822

**VULCAN**  
R842

DIM  
DIAxH(mm)

GRIT

PK  
QTY

BEST

BETTER



Flat

DIM DIAxH(mm)	GRIT	PK QTY	NORTON QUANTUM R928	OMEGA R828	NORSTAR RX22/R822	VULCAN R842
115x22	40	10	66261143314	63642502439	63642514924	63642502331
	60	10	66261143315	63642502440	63642514926	63642502332
	80	10	66261143317	63642502442		63642502333
	120	10	66261143318	63642502447		63642502334
125x22	40	10	66261143320	63642502444	63642550472	63642502335
	60	10	66261143321	63642502445	63642549401	63642502336
	80	10	66261143322	63642502448	63642549402	63642502337
	120	10	66261143323	63642502450		63642502340
180x22	40	10	66261143324		63642564417	
	60	10	66261143330			
	80	10	66261143331		63642549403	
	120	10	66261143332			

## FLEXI DISCS FLD FXSF

**NORZON**  
R822

DIM  
DIAxH(mm)

GRIT

PK  
QTY

BETTER

DIM DIAxH(mm)	GRIT	PK QTY	NORZON R822
115x22	40	10	63642544276
	60	10	63642544277
	80	10	63642544278
125x22	40	10	66261177415
	60	10	66261177416
	80	10	66261177417

## SHAPE KEY

Flat



Conical



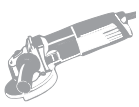

**PLASTIC BACKED**

**OMEGA**

**TWINSTAR**

R828

RX22/R822  
REINFORCED

DIM DIAxH(mm)	GRIT	PK QTY	BEST	
------------------	------	-----------	------	--



Flat

115x22	40	10	63642502451	63642545568
	60	10	63642502452	63642545570
	80	10		63642545571
125x22	40	10	63642502457	
	60	10	63642502458	
	80	10	63642502460	
	120	10	63642502461	
180x22	40	10		63642545575

**Dimensions Key:** DIM = Dimensions, DIA = Diameter, H = Hole



**SPEC CHECK**

- For an equivalent finish, always use a flap disc one grit size coarser than with a fibre disc
- Flat flap discs are designed to be used at an angle less than 15°



**MAXIMUM OPERATING SPEED**

DIA (mm)	MOS (m/s)	MAX RPM
115x22	80	13300
125x22	80	12200
180x22	80	8500



COATED  
ABRASIVES  
& BEARTEX

BONDED  
ABRASIVES

SUPER  
ABRASIVES

DIAMOND  
TOOLS

CLEANING,  
POLISHING  
& MASKING

PERSONAL  
PROTECTION  
EQUIPMENT

TECHNICAL  
INFORMATION

# SEMI-FLEXIBLE DISCS

Semi-flexible discs are made by coating heavy duty fibre with multiple layers of a special resin bonded abrasive. They can be used in a wide range of applications instead of depressed centre grinding wheels.

## APPLICATIONS & MARKETS

- Grinding welds
- Derusting large surfaces
- Cleaning hulls of ships & boats



COATED  
ABRASIVES  
& BEARTEX

BONDED  
ABRASIVES

SUPER  
ABRASIVES

DIAMOND  
TOOLS

CLEANING,  
POLISHING  
& MASKING

PERSONAL  
PROTECTION  
EQUIPMENT

TECHNICAL  
INFORMATION

BEST +++++

## Q400



### FEATURES



- High concentration of sharp silicon carbide abrasive
- Unique disc pattern

### BENEFITS

- For use on marble, granite, concrete, fibreglass & cast iron
- For heavy duty industrial applications
- Resists loading
- Cooler work area



Semi-flexible discs should be used on an angle grinder with a hard density back-up pad which has the same diameter as the disc. All semi-flexible discs have a maximum operating speed of 80m/s.

DIM DIxH(mm)	GRIT	PK QTY	MOUNDED /CONVEX	FLAT
127x22 	24	25	07660705207	
	36	25	07660707946	07660707454
	60	25	07660718494	
	80	25	07660707948	
180x22 	16	25	07660705202	07660717646
	24	25	07660705203	07660707931
	36	25	07660705204	07660707933
	60	25	07660705205	

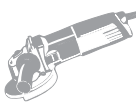

## CP FLEX

BETTER ++++





### FEATURES

- Sharp silicon carbide abrasive grain
- Unique disc pattern
- Shape: flat

### BENEFITS

- For use on marble, granite, concrete, fibreglass & cast iron
- Ideal for use in construction markets
- Resists loading
- Cooler work area

DIM DIAxH(mm)	GRIT	PK QTY	ART. NO.
127x22 	16	25	66261083476
	24	25	07660719292
	36	25	07660719293
	60	25	07660719294
	80	25	07660719295
180x22 	16	25	66261083479
	24	25	07660719296
	36	25	07660719297
	60	25	07660719298
	80	25	07660719299



All semi-flexible discs have a maximum operating speed of 80m/s.

## BACK-UP PADS

DIA (mm)	DENSITY	ATTACHMENT	PK QTY	ART. NO.
NYLON				
125	Hard	M14	5	69957382829
180	Hard	M14	5	69957382830

**Dimensions Key:** DIM = Dimensions, DIA = Diameter, H = Hole

COATED ABRASIVES & BEARTEX

BONDED ABRASIVES

SUPER ABRASIVES

DIAMOND TOOLS

CLEANING, POLISHING & MASKING

PERSONAL PROTECTION EQUIPMENT

TECHNICAL INFORMATION



# FLAP WHEELS

Flap wheels with internal M14 thread are the ideal tool for use on an angle grinder. Their design makes them ideal for sanding contours and uneven surfaces while delivering a consistent finish with a uniform rate of cut in a wide range of applications, Flap wheels are conformable to intricate shapes and contours.

Very easy to operate:

- No adjustments, dressing, or preparation required before or during operation

Fewer rejected parts:

- More forgiving than other abrasive products
- Reduce the possibility of flattening, gouging and surface deformation

## APPLICATIONS & MARKETS

- Blending, deburring & finishing
- Metal fabrication, welding & polishing



COATED ABRASIVES & BEARTEX

BONDED ABRASIVES

SUPER ABRASIVES

DIAMOND TOOLS

CLEANING, POLISHING & MASKING

PERSONAL PROTECTION EQUIPMENT

TECHNICAL INFORMATION

GOOD +++

## BDX R207

WITH INTERNAL M14 THREAD

**BDX**



Universal product for steel and stainless steel but also for paint removal, plastic or wood.

### FEATURES

- Premium aluminum oxide grain
- Flexible cotton backing
- M14 thread

### BENEFITS

- For aggressive cut and longer life
- Excellent cut rate on low-pressure finishing operations
- Conformable to the workpiece
- Quick and easy to mount on angle grinder

DIM DIAxW (mm)	GRIT						RECOMMEND SPEED (RPM)	PK QTY
	P40	P60	P80	P120	P180	P320		
115x20	66261121351	66261121353	66261121411	66261121415	66261121423	66261121425	6700 - 8300	5
125x20	66261121426	66261121427	66261121428	66261121429	66261121432	66261121435	6000 - 7700	5



### SPEC CHECK

To prevent unnecessary tool wear do not increase the contact pressure too much, the increase of stock removal should be achieved by using a coarser grit size.

To get a slightly finer surface increase the cutting speed.

To get a slightly rougher finishing increase the contact pressure.

Using same grit size, the finishing is rougher on softer materials.

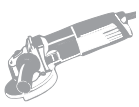

# BLENDING

Unique compacted structure design offers material removal while imparting a final smear free finish. Ideal for deburring, edge breaking, blending, cleaning and polishing. Durable construction for fast, economical surface preparation. Can be used in sequence with, fibre and flap discs, to de-burr, blend and impart great finishes in one or two operations.

## APPLICATIONS & MARKETS

- Conditioning grindlines
- Blending surface defects
- Deburring and radiusing edges
- Light stock removal



COATED  
ABRASIVES  
& BEARTEX

BONDED  
ABRASIVES

SUPER  
ABRASIVES

DIAMOND  
TOOLS

CLEANING,  
POLISHING  
& MASKING

PERSONAL  
PROTECTION  
EQUIPMENT

TECHNICAL  
INFORMATION

## BLAZE RAPID BLEND DPC TYPE 27 (OPEN)

BEST +++++



### FEATURES

- Blaze Ceramic grain
- Erodible substrate
- Versatile disc

### BENEFITS

- Increased life, 2 discs replace a 5-step SCM process
- Means consistent, smear and load free cutting action
- Ideal for cleaning, de-burring or blending quickly with added aggression

DIM DIAxTxH(mm)	CAP CODE	GRADE	APPLICATION	PK QTY	MAX RPM	ART. NO.
125x6x22	U9101	Blaze XCOA	Tig Weld removal	10	12000	77696067121

**Dimensions Key:** DIM = Dimensions, DIA = Diameter, W = Width, T = Thickness, H = Hole

## NEW BEARTEX NON-WOVEN WEBSITE

Scan the QR code or visit website using the web address below.

[www.nortonbeartex.com](http://www.nortonbeartex.com)



WEBSITE LINK

## VORTEX RAPID BLEND

DPC TYPE 27

BETTER ++++

**VORTEX**  
RAPID BLEND



2 in 1: can cut like an 80 grit flap disc and finishes similar to an NEX 25F Rapid Finish disc

### FEATURES

- High-performance engineered grain
- Thick Nylon web
- No need to change power tools
- Undersized backing plate

### BENEFITS

- Aggressive, fast stock removal, reduced cycle times and increased part quality
- Longer life and more parts per disc. resists loading
- Can be used in place of, or in sequence with, fibre and flap discs for improved part quality
- Longer usable diameter



Max operating speed:  
12 000rpm

DIM DIAxTxH(mm)	CAP CODE	GRADE	APPLICATION	PK QTY	MAX RPM	ART. NO.
115x12x22	U2305	VORTEX 5AM	Tig Weld removal	10	12000	66254429268
125x12x22	U2305	VORTEX 5AM	Tig Weld removal	10	12000	66254496323
115x12x22	U2305	VORTEX 3AM	Tig Weld removal	10	7500	66623392701
125x12x22	U2305	VORTEX 3AM	Tig Weld removal	10	7500	66623392718
115x6x22	U2305	VORTEX 5AM	Tig Weld removal	10	12000	77696067099
125x6x22	U2305	VORTEX 5AM	Tig Weld removal	10	12000	77696067103
115x6x22	U2305	VORTEX 3AM	Tig Weld removal/ contours	10	12000	77696067105
125x6x22	U2305	VORTEX 3AM	Tig Weld removal/ contours	10	12000	77696067110

## VORTEX RAPID BLEND

DPC TYPE 29 CONICAL

**VORTEX**  
RAPID BLEND



DIM DIAxTxH(mm)	CAP CODE	GRADE	APPLICATION	PK QTY	MAX RPM	ART. NO.
125x12x22	U2305	VORTEX 5AM	Tig Weld removal	10	12000	63642531710
125x12x22	U2305	VORTEX 3AM	Tig Weld removal	10	7500	63642531717

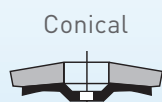

Conical

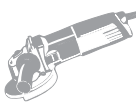

## RAPID BLEND

NEX DPC TYPE 27

GOOD +++



### FEATURES

- Fine silicon carbide & flexible double density Unitised construction
- Wide range of solutions for finishing ferrous and non-ferrous materials
- Modified resin system
- Undersized backing plate

### BENEFITS

- Excellent for fine, consistent satin finish
- Longer life and more parts per disc, resists loading
- Cuts more freely and with less heat than competitor products
- Longer usable diameter

DIM DIAxTxH(mm)	CAP CODE	GRADE	APPLICATION	PK QTY	MAX RPM	ART. NO.
115x12x22	U4401	NEX2SF	Blend & Finish	10	12000	66261020546
	U4401	NEX3SF	Blend & Finish +	10	12000	66254461726
	U2401	NEX2AF	Multi-purpose	10	12000	66261020547
	U2301	NEX2AM	Most aggressive	10	12000	66261020548
	F2303	HIGH STRENGTH HSMA	Most conformable	10	12000	66261020549
125x12x22	U4401	NEX2SF	Blend & Finish	10	12000	66254496320
	U4401	NEX3SF	Blend & Finish	10	12000	77696067125
115x6x22	U4401	NEX2SF	Blend & Finish	10	12000	77696067115
	U4401	NEX3SF	Blend & Finish	10	12000	77696067116
125x6x22	U4401	NEX2SF	Blend & Finish	10	12000	77696067118
	U4401	NEX3SF	Blend & Finish	10	12000	77696067119

COATED ABRASIVES & BEARTEX

BONDED ABRASIVES

SUPER ABRASIVES

DIAMOND TOOLS

CLEANING, POLISHING & MASKING

PERSONAL PROTECTION EQUIPMENT

TECHNICAL INFORMATION

## RAPID BLEND

NEX DPC TYPE 29 CONICAL



DIM DIAxTxH(mm)	CAP CODE	GRADE	APPLICATION	PK QTY	MAX RPM	ART. NO.
125x12x22	U4401	NEX2SF	Blend & Finish	10	12000	63642531722
	U4401	NEX3SF	Blend & Finish	10	12000	63642531723

**Dimensions Key:** DIM = Dimensions, DIA = Diameter, T = Thickness, H = Hole



Conical

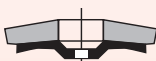



## VORTEX RAPID PREP

### SCM FLAP DISCS

BETTER ++++

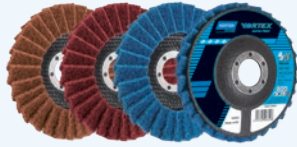
**VORTEX**  
RAPID PREP

#### FEATURES

- Layers of Surface Conditioning Material in a variety of grades to suit your application
- Special, three-dimensional non-woven abrasive fabric layers
- High Performance Vortex grain and Clean Bond resin
- Perfect complement to Flap and Fibre discs in the Blending and finishing process

#### BENEFITS

- Quick, durable blending and finishing tool
- Ensures uniform finishing with a consistently low Ra value
- Longer life and durability with smear free cut & finish in 1 action
- Ideal for Cleaning and light de-burring work and the processing of TIG-welded seams on stainless steel

DIM DIAxH(mm)	CAP CODE	GRADE	PK QTY	MAX RPM	ART. NO.
115x22	S2203	Coarse	10	12200	66261130726
	S2303	Medium	10	12200	66261130773
	S2403	Fine	10	12200	66261130776
	S2503	Very Fine	10	12200	66261130777
125x22	S2203	Coarse	10	12200	66261130779
	S2303	Medium	10	12200	66261130780
	S2403	Fine	10	12200	66261130781
	S2503	Very Fine	10	12200	66261130782

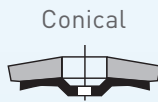

#### SPEC CHECK

Where can a Rapid Blend T27 disc be used?

They can be used in conjunction with flap discs. In some cases, the unitized discs can replace a flap disc. The flap disc leaves scratches on the workpiece. The Rapid Blend disc will remove the coated abrasive scratches, providing a smoother, burr-free finish. They provide a clean bright surface finish on stainless steel.

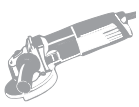

## VORTEX RAPID PREP

SCM SELF-GRIP<sup>†</sup> WITH REMOVABLE 22mm CENTRE HOLE



### FEATURES

- New resin system & proprietary Vortex grain
- New coating technology
- Combine the cutting speed of coarse grits with the finish of fine grits
- Reduce process time by 50%+
- More resistant to edge wear

### BENEFITS

- Smear free, does not load on aluminium or soft metals
- Thick layer of grain extends product life
- Lowest total cost of consumable tooling per workpiece
- Eliminate 2 to 5 grit sequences to 1 step
- Has up to 4x longer life vs. competitor products

DIA (mm)	CAP CODE	GRADE	PK QTY	ART. NO.
115	S2103	Extra Coarse	25	66623378971
	S2203	Coarse	25	66623378974
	S2303	Medium	25	66623378977
	S2403	Fine	25	66623333607
	S2503	Very Fine	25	66623378980
125	S2103	Extra Coarse	25	66623378972
	S2203	Coarse	25	66623378975
	S2303	Medium	25	66623378978
	S2403	Fine	25	66623333609
	S2503	Very Fine	25	66623378981
178	S2103	Extra Coarse	25	66623378973
	S2203	Coarse	25	66623378976
	S2303	Medium	25	66623378979
	S2403	Fine	25	66623334955*
	S2503	Very Fine	25	66623334969*

\* Made-to-order

**Dimensions Key:** DIM = Dimensions, DIA = Diameter, T = Thickness, H = Hole

<sup>†</sup> To help better describe the abrasive fixing system we have changed the name from 'NorGrip' to 'Self-Grip'.



SPEC CHECK  
Colour codes.

GRADE	COLOUR
Extra Coarse	Black
Coarse	Brown
Medium	Maroon
Fine	Green
Very Fine	Blue

COATED  
ABRASIVES  
& BEARTEX

BONDED  
ABRASIVES

SUPER  
ABRASIVES

DIAMOND  
TOOLS

CLEANING,  
POLISHING  
& MASKING

PERSONAL  
PROTECTION  
EQUIPMENT

TECHNICAL  
INFORMATION

# RAPID PREP

SCM (A0) SELF-GRIP<sup>†</sup> WITH REMOVABLE 22mm CENTRE HOLE

GOOD +++

**Rapid**  
**PREP**



## FEATURES

- Open structure
- High abrasive content
- Flexible backing
- General purpose

## BENEFITS

- Resists loading on softer materials
- Fast initial cut rate
- Conforms to surface contours
- Very versatile

DIA (mm)	CAP CODE	GRADE	PK QTY	ART. NO.
115	S2108	Extra Coarse	25	66623378983
	S2208	Coarse	25	66623378984
	S2308	Medium	25	66623378987
	S2408	Fine	25	66623378990
	S2508	Very Fine	25	66623379028
125	S2108	Extra Coarse	25	66623378982
	S2208	Coarse	25	66623378985
	S2308	Medium	25	66623378988
	S2408	Fine	25	66623378991
	S2508	Very Fine	25	66623379029
178	S2108	Extra Coarse	25	66623378965
	S2208	Coarse	25	66623378986
	S2308	Medium	25	66623378989
	S2408	Fine	25	66261199465*
	S2508	Very Fine	25	66261019990*

Other sizes and grades available on MTO basis

\* Made-to-order

<sup>†</sup> To help better describe the abrasive fixing system we have changed the name from 'NorGrip' to 'Self-Grip'.

## PRODUCT SELECTION

WHICH GRADE SHOULD I CHOOSE?	
GRADE	FEATURES & BENEFITS
Extra Coarse	Provides longest cutting life & highest aggressiveness to quickly achieve an even surface ready for finer finishing. Ideal for descaling & removing heavy rust & oxides, ideal for deburring, aluminium & excellent performance on hard materials
Coarse	Ideal where a less coarse finish or increased flexibility is required & an aggressive cut is necessary Removes 60-120 grit grindlines - for light deburring
Medium	Removes 120-180 grit grindlines - for cleaning & rust removal
Very Fine	Provides an excellent & uniform finish, ideal choice for fine finishing & pre-coat finishing Removes 180-320 grit grindlines - for finishing, polishing & paint preparation
Super Fine	The finest & most flexible surface conditioning for decorative finishes & excellent surfaces on soft & hard metals, ideal for pre-polishing

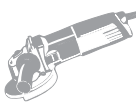

## SURFACE BLENDING DISCS FIBRE BACKED

AO SBM



### FEATURES

- Durable fibre construction
- Very sharp abrasive grain
- Rigid, low stretch backing
- Controlled cut & comfortable to use
- Remove and attach quickly (Use with Self-Grip<sup>+</sup> back-up pads)
- Extra coarse grade for de-burring aluminium

### BENEFITS

- Long lasting and cool running
- High, continuous cut rate, resistant to loading and clogging
- Excellent performance on hard materials including steels, nickel, alloys etc.
- Consistent finish
- Ideal for sequential finishing using consecutively finer grades
- Reduced clogging or loading

FB\* = Fibre backed and with 22mm hole (for a stiffer, higher performing disc)

DIM DIA(mm)	CAP CODE	GRADE	TYPE	PK QTY	ART. NO.
115	S2211	Coarse FB*	DSB	20	63642557510
125	S2211	Coarse FB*	DSB	20	63642557721
150	S2211	Coarse FB*	DSB	10	63642557727

## BACK-UP PADS (SELF-GRIP<sup>+</sup>) WITH LOCATING CENTRE PIN

DIA (mm)	DENSITY	ATTACHMENT	PK QTY	ART. NO.
SELF-GRIP <sup>+</sup> FOR BEARTEX				
115	Medium	M14	1	77696076935
125	Medium	M14	1	77696076941
178	Medium	M14	1	63642575296



## BACK-UP PADS (SELF-GRIP<sup>+</sup>)

DIA (mm)	DENSITY	ATTACHMENT	PK QTY	ART. NO.
SELF-GRIP <sup>+</sup> FOR BEARTEX				
115	Medium	M14	1	69957382846
	Medium	5/8	1	63642595937
125	Medium	M14	1	69957382841
	Medium	5/8	1	63642595938
150	Medium	M14	1	69957382843
	Medium	5/8	1	63642595939
178	Medium	M14	1	69957382844
	Medium	5/8	1	63642595940

**Dimensions Key:** DIA = Diameter

<sup>†</sup> To help better describe the abrasive fixing system we have changed the name from 'NorGrip' to 'Self-Grip'.

COATED ABRASIVES & BEARTEX

BONDED ABRASIVES

SUPER ABRASIVES

DIAMOND TOOLS

CLEANING, POLISHING & MASKING

PERSONAL PROTECTION EQUIPMENT

TECHNICAL INFORMATION



## VORTEX RAPID PREP

SCM (A0) SELF-GRIP<sup>†</sup> DISCS - SAMPLE PACKS

BETTER ++++

**VORTEX**  
RAPID PREP



KIT and DIA SIZE	PK QTY	ART. NO.
H&L DISC KIT RAPIDPREP VORTEX 115	5 discs of each grade	77696000365*
H&L DISC KIT RAPIDPREP VORTEX 125	5 discs of each grade	77696000553*

\* Made-to-order

## RAPID PREP

SCM (A0) SELF-GRIP<sup>†</sup> DISCS - SAMPLE PACKS

GOOD +++

**Rapid**  
PREP



KIT and DIA SIZE	PK QTY	ART. NO.
H&L DISC KIT RAPIDPREP 115	5 discs of each grade	77696000555*
H&L DISC KIT RAPIDPREP 125	5 discs of each grade	77696000556*

\* Made-to-order

<sup>†</sup> To help better describe the abrasive fixing system we have changed the name from 'NorGrip' to 'Self-Grip'.

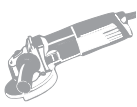

# STRIPPING & CLEANING

Rapid Strip discs are constructed with thick, strong, synthetic fibres and extra-coarse silicon carbide abrasive.

The open web construction of the disc provides fast cutting action with very little loading.

Safer than wire bristle tools, Rapid Strip is suitable for use in many industries.

## APPLICATIONS & MARKETS

- Removal of surface rust & residue, corrosion, light weld splatter, dirt, mill scale & other similar surface contaminants
- Paint & epoxy coating removal
- Surface preparation before applying coatings
- Surface preparation before welding
- Cleaning & conditioning after welding



COATED  
ABRASIVES  
& BEARTEX

BONDED  
ABRASIVES

SUPER  
ABRASIVES

DIAMOND  
TOOLS

CLEANING,  
POLISHING  
& MASKING

PERSONAL  
PROTECTION  
EQUIPMENT

TECHNICAL  
INFORMATION

BEST +++++

## BLAZE RAPID STRIP DPC TYPE 27



### FEATURES

- Heavy coating of Norton SG Blaze ceramic alumina long-lasting grain and advanced resin bond
- Open structure

### BENEFITS

- Lasts 2x longer than competitive products
- Does not shed on rust-encrusted pieces, or load on soft metals
- Lighter pressure will finish similar to a medium grit surface conditioning disc; additional pressure will remove material (strip and clean)
- Less downtime, and less production waste/landfill scrap



VIDEO LINK

DIM DIAxH(mm)	CAP CODE	PK QTY	MAX RPM	ART. NO.
115x22	R9101	10	12000	66623303783
125x22	R9101	10	11000	66623303916
178x22	R9101	10	8000	66623303920

**Dimensions Key:** DIM = Dimensions, DIA = Diameter, H = Hole

## BLAZE RAPID STRIP

DPC TYPE 29 CONICAL



DIM DIAxH(mm)	CAP CODE	PK QTY	MAX RPM	ART. NO.
125x22	R9101	10	12000	66261118630

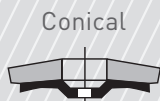

Conical

## RAPID STRIP

DPC TYPE 27

GOOD +++



### FEATURES

- Open web construction
- Conformable
- Thick, strong, synthetic fibres & extra coarse grit
- NEW R4101 H with harder density

### BENEFITS

- Fast cutting action with very little loading
- Easy cleaning of uneven surfaces
- Long life

DIM DIAxH(mm)	CAP CODE	PK QTY	MAX RPM	STRIPPA R4104 S	RAPID STRIP R4101 H
115x22	R4101	10	12000		66261009649
	R4104	5	11000	63642585732	
125x22	R4101	10	12000		66261030655
	R4104	5	8500	63642585749	
178x22	R4101	10	9000		66261009586
	R4104	5	6500	63642585750	



### SPEC CHECK

- Perfect product for rust, paint and corrosion removal

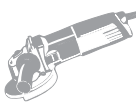

## FINISHING & POLISHING

Finishing is a penultimate step to reduce surface roughness, apply a cosmetic finish and prepare the surface for polishing.

### APPLICATIONS & MARKETS

- Prepare the surface for polishing, painting & coatings
- Remove scratch lines
- Provides high quality mirror shine



COATED  
ABRASIVES  
& BEARTEX

BONDED  
ABRASIVES

SUPER  
ABRASIVES

DIAMOND  
TOOLS

CLEANING,  
POLISHING  
& MASKING

PERSONAL  
PROTECTION  
EQUIPMENT

TECHNICAL  
INFORMATION

### BEARTEX FLAP DISC

GOOD +++



**BearTex**®

#### FEATURES

- Beartex fleece discs with open mesh construction
- Two types available, plain & interleaved

#### BENEFITS

- Conforms easily to surface contours and shapes
- For use on a number of metals

DIM DIAxB(mm)	CAP CODE	GRADE	TYPE	PK QTY	MAX RPM	ART. NO.
115x22	F2504	Very Fine A	XFLD (Plain)	10	4900	66254481898
	F2504	Very Fine A with P120	XIFD (Mixed)	10	4900	66623311000

Optimum performance when run at slower speeds on a variable speed power tool.

### RAPID POLISH

**Rapid**  
POLISH



#### FEATURES

- Type 29 felt wool polishing pad
- Use with or without polishing compound

#### BENEFITS

- Smooth, scratch free result
- For a professional, mirror shine

DIM DIAxB(mm)	CAP CODE	GRADE	TYPE	PK QTY	MAX RPM	ART. NO.
115x22	F0005	Felt	XFLD (Plain)	10	8500	66254481899
125x22	F0005	Felt	XFLD (Plain)	10	7700	63642573692

Optimum performance when run at slower speeds on a variable speed power tool.

**Dimensions Key:** DIM = Dimensions, DIA = Diameter, H = Hole, B = Bore



## POLISHING PASTE BARS



A range of Polishing blocks designed to be used with our RapidPolish felt products, for cleaning and polishing a wide variety of metals to achieve a high gloss finish.

DIM WxLxH(mm)	COLOUR	SPECIFICATION	GUIDE	PK QTY	ART. NO.
55x160x38	BROWN	Pre-polishing	Cleaning very Dirty material - especially aluminium & non ferrous	1	07660739107
	GREEN	Gloss finish	Good for aluminium & stainless steel	1	07660739108
	WHITE	Super high gloss finish	Polishing stainless steel and aluminium & non-ferrous	1	07660739109
	BLUE	General purpose with high gloss finish	All metals and hard plastics	1	07660739112

**Dimensions Key:** DIM = Dimensions, W = Width, L = Length, H = Height

# 117-140

## DISCS FOR MINI GRINDER



118 Mini Flap Discs  
121 Speedlok Discs

128 Blending  
131 Surface Preparation

134 Stripping & Cleaning  
136 Polishing

COATED  
ABRASIVES  
& BEARTEX

BONDED  
ABRASIVES

SUPER  
ABRASIVES

DIAMOND  
TOOLS

CLEANING,  
POLISHING  
& MASKING

PERSONAL  
PROTECTION  
EQUIPMENT

TECHNICAL  
INFORMATION

# MINI FLAP DISCS

For high stock removal, ideal for weld dressing on small and difficult to access areas, with longer life and improved productivity by minimizing downtime.

The Speedlok fastener makes it quick & easy to change discs by locking securely to the back-up pad, so no slipping or release is caused by heat build-up. The 2 button attachment systems (SL3 & SL2) ensure the disc is properly centred and vibration free.

Best performance is achieved at a recommended speed of 30-40m/s. This optimises stock removal, surface finish, thermal load of the workpiece and tool wear.

## APPLICATIONS & MARKETS

- Stock removal, deburring, deflashing, blending and finishing welds in metal fabrication and MRO shops.



COATED  
ABRASIVES  
& BEARTEX

BONDED  
ABRASIVES

SUPER  
ABRASIVES

DIAMOND  
TOOLS

CLEANING,  
POLISHING  
& MASKING

PERSONAL  
PROTECTION  
EQUIPMENT

TECHNICAL  
INFORMATION

## BLAZE R980P

BEST +++++

**BLAZE**



The BEST choice for stainless steel and super alloys.

### FEATURES

- Latest generation ceramic alumina abrasive
- Supersize grinding aid

### BENEFITS

- For aggressive and quick operations
- Provides longer life vs any mini flap discs on stainless, titanium and super alloys
- Provides a cool and noticeably faster cut rate

## SPEEDLOK DISCS TR ATTACHMENT (TYPE 3 – SL3)



DIA (mm)	GRIT				RECOMMEND SPEED (RPM)	BACKUP PAD	PK QTY
	P36	P40	P60	P80			
50	66261120103	66261120104	66261120109	66261120110	11500 - 15000	63642556629	10
75	66261120111	66261120112	66261120116	66261120117	7500 - 10000	63642556629	10

Other grits and discs with SL2 attachment available upon request.



## X-TREME R884P

BETTER ++++

**X-TREME**



The BETTER choice for carbon steel and welds.

### FEATURES

- Strong zirconia alumina plus abrasive
- Semi-open coat

### BENEFITS

- Delivers aggressive cut rate and longer life on carbon steel and welds
- Prevents loading on aluminum and other soft materials

## SPEEDLOK DISCS TR ATTACHMENT (TYPE 3 - SL3)

DESCRIPTION	DIA (mm)	GRIT			RECOMMEND SPEED (RPM)	BACKUP PAD	PK QTY
		P40	P60	P80			
Mini flap discs	50	66261180892	66261180893	66261180894	11500 - 15000	63642556629	10
	75	63642527476	66261180904	63642527482	7500 - 10000	63642556629	10

Other grits and discs with SL2 attachment available upon request.



Also available in mini flexi-flap disc, which adapts to contours and corners. The flexible cloth and disc construction is ideal for an improved finish and operator comfort during use.

## SPEEDLOK DISCS TR ATTACHMENT (TYPE 3 - SL3)

DESCRIPTION	DIA (mm)	GRIT			RECOMMEND SPEED (RPM)	BACKUP PAD	PK QTY
		P40	P60	P80			
Mini-flexi flap discs	50	66261180889	66261180890	66261180891	11500 - 15000	63642556629	10

Other grits and discs with SL2 attachment available upon request.

**Dimensions Key:** DIA = Diameter

COATED ABRASIVES & BEARTEX

BONDED ABRASIVES

SUPER ABRASIVES

DIAMOND TOOLS

CLEANING, POLISHING & MASKING

PERSONAL PROTECTION EQUIPMENT

TECHNICAL INFORMATION



BDX R766

GOOD +++

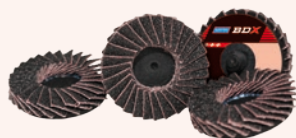
**BDX**

The GOOD choice for aluminum, carbon steel and difficult-to-grind materials that require an economical option.

**FEATURES**

- Premium abrasive and aluminum oxide blend

- New grain coating

**BENEFITS**

- For aggressive cut and longer life than competitive aluminum oxide discs
- Good for difficult-to-grind materials (aluminum, brass, bronze, stainless, carbon steel, and titanium) and applications requiring an economical option
- For longer life and faster cut rate on moderately-demanding applications

**SPEEDLOK DISCS TR ATTACHMENT (TYPE 3 - SL3)**

DIA (mm)	GRIT				RECOMMEND SPEED (RPM)	BACKUP PAD	PK QTY
	P40	P60	P80	P120			
50	66261119970	66261119973	66261119975	66261119976	11500 - 15000	63642556629	10
75	66261119979	66261119980	66261119981	66261119982	7500 - 10000	63642556629	10

Other grits and discs with SL2 attachment available upon request.





# SPEEDLOK DISCS

The tool-free fastening system enables quick disc changes to maximize productivity and minimise downtime.

Ideal for working on small or difficult to access areas like tool and mold construction, automotive, aeronautical & aerospace industry and equipment and pressure vessel construction.

Speedlok fastener makes it quick & easy to change. Disc locks securely to back-up pad, no slipping or release caused by heat. 2 button attachment systems ensuring disc properly centered and vibration free operation.

Optimizing stock removal, surface finish, thermal load of the workpiece and tool wear.

Speedlok discs achieve their best performance at a recommended speed of 15-35m/s.

## APPLICATIONS & MARKETS

- Light to medium pressure grinding, blending & finishing
- For contoured or flat surfaces



COATED  
ABRASIVES  
& BEARTEX

BONDED  
ABRASIVES

SUPER  
ABRASIVES

DIAMOND  
TOOLS

CLEANING,  
POLISHING  
& MASKING

PERSONAL  
PROTECTION  
EQUIPMENT

TECHNICAL  
INFORMATION

## BLAZE R980P

BEST +++++

**BLAZE**



The BEST choice for part cut & finish on stainless steel, inconels, chromium cobalt, titanium and extremely hard materials.

### FEATURES

- Next-generation, Norton SG ceramic alumina grain with self-lubricating, supersize treatment
- 3-ply heavy-duty laminate discs (Y-weight polyester yellow backing)

### BENEFITS

- Provides coolest cut and significantly faster cut rates
- Aggressive disc will help you to remove all defects quickly
- More aggressive; for greatest durability, longest life, and edge-fray resistance on tough applications and stainless steel

## SPEEDLOK DISCS TR ATTACHMENT (TYPE 3 - SL3)

DIA (mm)	GRIT						RECOMMEND SPEED (RPM)	PK QTY
	P24	P36	P50	P60	P80	P120		
25		66261094895	66254402096	66261038811			11500 - 26800	100
38		63642597033	63642597034	63642597037	63642597038	66261136867	7600 - 17600	50
50	66261137594	63642597039	63642597045	63642597050	63642597052	66261136868	5700 - 13400	50
75	66261137596	63642597053	63642597057	63642597060	63642597062	66261136980	3800 - 8900	50

## SPEEDLOK DISCS TS ATTACHMENT (TYPE 2 - SL2)

DIA (mm)	GRIT						RECOMMEND SPEED (RPM)	PK QTY
	P24	P36	P50	P60	P80	P120		
25		66254402097	66254402098	66261094680	66254402099		11500 - 26800	100
38		69957390693	69957390694	69957390695	69957390696	66261136984	7600 - 17600	50
50	66261137580	69957390698	69957390699	69957390700	69957390701	66261136986	5700 - 13400	50
75	66261137590	69957390702	69957390703	69957390704	69957390705	66261136987	3800 - 8900	50

Other grits available upon request.

**Dimensions Key:** DIA = Diameter

# BLAZE F980 FIBER



The BEST choice for tough applications.

### FEATURES

- Heaviest fiber backing

### BENEFITS

- For greater stock removal, longer life and edge-fray resistance

## SPEEDLOK DISCS TR ATTACHMENT (TYPE 3 - SL3)



DIA (mm)	GRIT			RECOMMEND SPEED (RPM)	PK QTY
	P36	P50	P60		
50	66261058704	66261058705	66261058706	5700 - 13400	25
75	66261058708	66261058709	66261058711	3800 - 8900	25

COATED ABRASIVES & BEARTEX

BONDED ABRASIVES

SUPER ABRASIVES

DIAMOND TOOLS

CLEANING, POLISHING & MASKING

PERSONAL PROTECTION EQUIPMENT

TECHNICAL INFORMATION



# X-TREME R884P

BETTER ++++



The BETTER choice for hard steels, wood and carbon steel.

### FEATURES

- Premium, versatile, self-sharpening zirconia alumina plus grain
- Strong resin bond
- Advanced grain coating
- Semi-open coat
- Durable, Y-wt, 2-ply polyester backing

### BENEFITS

- Provides aggressive cut and longer life than competitive zirconia alumina product
- Improves base adhesion and reduces grain shedding
- Results in longer life and faster cut rate
- Retards loading on soft metals (aluminum, brass, and bronze) and wood, as well as stainless steel and carbon steel
- Stands up to demanding applications: high-pressure and hard-to-grind exotic alloy

## SPEEDLOK DISCS TR ATTACHMENT (TYPE 3 - SL3)

DIA (mm)	GRIT					RECOMMEND SPEED (RPM)	MAX SPEED (RPM)	PK QTY
	P36	P50	P60	P80	P120			
38	63642560879		63642560880	66261137001		7600 - 17600	25100	50
50	63642560882	69957389455	63642556396	63642560884	63642560885	5700 - 13400	19000	50
75	63642560886	69957389465	63642560887	63642560888	66261137003	3800 - 8900	12700	50

## SPEEDLOK DISCS TS ATTACHMENT (TYPE 2 - SL2)

DIA (mm)	GRIT					RECOMMEND SPEED (RPM)	PK QTY
	P36	P50	P60	P80	P120		
38	63642549604	66261138622	63642549607	63642549606		7600 - 17600	50
50	63642549747	69957360306	63642549748	63642549749	66261115917	5700 - 13400	50
75	63642549605	69957360307	63642539858	69957360313	66261137005	3800 - 8900	50

Other grits available upon request.

**Dimensions Key:** DIA = Diameter

COATED ABRASIVES & BEARTEX

BONDED ABRASIVES

SUPER ABRASIVES

DIAMOND TOOLS

CLEANING, POLISHING & MASKING

PERSONAL PROTECTION EQUIPMENT

TECHNICAL INFORMATION



# X-TREME R801



The BETTER choice for demanding grinding applications. Grinding aid results in cooler cut on stainless steel, titanium and other exotic alloys.

### FEATURES

- Premium Zirconia plus grain
- Heavy Y-weight polyester backing

### BENEFITS

- High removal rate in stainless steel
- For a better cut and cool grinding on exotic alloys
- Provides excellent durability and grain adhesion

## SPEEDLOK DISCS TR ATTACHMENT (TYPE 3 - SL3)

DIA (mm)	GRIT					RECOMMEND SPEED (RPM)	PK QTY
	P36	P50	P60	P80	P120		
50	63642556405	63642587202	63642556407	63642587207	63642587208	5700 - 13400	50
75	63642587245	63642587246	63642556411	63642587247	63642587248	3800 - 8900	50

## SPEEDLOK DISCS TS ATTACHMENT (TYPE 2 - SL2)

DIA (mm)	GRIT					RECOMMEND SPEED (RPM)	PK QTY
	P36	P50	P60	P80	P120		
50	63642556399	63642587194	63642556403	63642587203	63642587204	5700 - 13400	50
75	63642587209	63642587210	63642556408	63642587214	63642587217	3800 - 8900	50





## X-TREME R422



The BETTER choice for brass, non-ferrous materials, stone, glass and fibre reinforced plastics.

### FEATURES

- Sharp premium silicon carbide abrasive

### BENEFITS

- For high initial cut and penetration for brass and nonferrous materials
- Ideal solution for titanium and non-ferrous aircraft and engine parts grinding

### SPEEDLOK DISCS TR ATTACHMENT (TYPE 3 - SL3)

DIA (mm)	GRIT			RECOMMEND SPEED (RPM)	PK QTY
	P60	P80	P120		
38	66261137013	66261137024	66261137027	7600 - 17600	50
50	66261137014	66261137025	66261137028	5700 - 13400	50
75	66261137015	66261137026	66261137029	3800 - 8900	50

### SPEEDLOK DISCS TS ATTACHMENT (TYPE 2 - SL2)

DIA (mm)	GRIT			RECOMMEND SPEED (RPM)	PK QTY
	P60	P80	P120		
38	66261137033	66261137037	66261137040	7600 - 17600	50
50	66261137034	66261137038	66261137042	5700 - 13400	50
75	66261137035	66261137039	66261137043	3800 - 8900	50

Other grits available upon request.

**Dimensions Key:** DIA = Diameter

COATED ABRASIVES & BEARTEX

BONDED ABRASIVES

SUPER ABRASIVES

DIAMOND TOOLS

CLEANING, POLISHING & MASKING

PERSONAL PROTECTION EQUIPMENT

TECHNICAL INFORMATION

BDX ARY19

GOOD +++

**BDX**

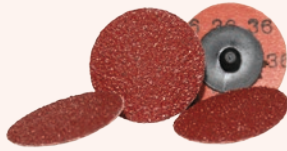

The GOOD choice for difficult-to-grind materials that require an economical option.

**FEATURES**

- Premium abrasive and aluminum oxide blend
- Durable Y-weight 2-ply polyester backing
- New grain coating

**BENEFITS**

- For aggressive cut and longer life than competitive aluminum oxide discs
- Great for difficult-to-grind materials (aluminum, brass, bronze, stainless, carbon steel, and titanium) and applications requiring an economical option
- Durability for edge wear and fray resistance
- For longer life and faster cut rate on moderately-demanding applications

**SPEEDLOK DISCS TR ATTACHMENT (TYPE 3 – SL3)**



DIA (mm)	GRIT							RECOMMEND SPEED (RPM)	PK QTY
	P36	P50	P60	P80	P120	P180	P320		
25	66261137045*	66261137047*	66261137048	66261137049	66261137055	66261137056	66261137057	11500 - 26800	100
38	63642586622*	63642586626*	63642586628	63642586629	63642586631	63642586633	66261137058	7600 - 17600	50
50	63642586683	63642586685	69957389332	63642586687	63642586689	63642586691	63642586695	5700 - 13400	50
75	63642586723	63642586728	63642586731	63642586733	63642586735	63642586738	66261137060	3800 - 8900	50

\* Made-to-order

**SPEEDLOK DISCS TS ATTACHMENT (TYPE 2 – SL2)**



DIA (mm)	GRIT							RECOMMEND SPEED (RPM)	PK QTY
	P36	P50	P60	P80	P120	P180	P320		
25	66261137050*	66261137052*	66261137053	66261137054	66261137063	66261137064	66261137065	11500 - 26800	100
38	63642586583*	63642586587*	63642586596	63642586607	63642586608	63642586609	63642586617	7600 - 17600	50
50	63642586651	63642586654	63642586656	63642586660	63642586671	63642586675	63642586681	5700 - 13400	50
75	63642524390	63642586697	63642586699	63642586705	63642586708	63642586712	63642586718	3800 - 8900	50

**Dimensions Key:** DIA = Diameter

\* Made-to-order

COATED ABRASIVES & BEARTEX

BONDED ABRASIVES

SUPER ABRASIVES

DIAMOND TOOLS

CLEANING, POLISHING & MASKING

PERSONAL PROTECTION EQUIPMENT

TECHNICAL INFORMATION



## PRODUCT SELECTION GUIDE

MATERIALS / APPLICATIONS	HIGHLY RECOMMENDED	RECOMMENDED	SUITABLE
Stainless steel/heat sensitive alloys	R980P	R884P	ARY19
Carbon steel/weld/ferrous metal	R980P	R884P	ARY19
Non-ferrous metal/brass/aluminium	R422		
MATERIALS / APPLICATIONS	DEBURRING	CLEANING	BLEND/FINISH
All metal - using SBM	S2203 Vortex	S2303 Vortex	S2303 Vortex
All metal - using unitised	U2305 Vortex	U4401	U4401
All metal with minimal or no stock removal	F2303 HS	R4101	F2300

COATED  
ABRASIVES  
& BEARTEX

BONDED  
ABRASIVES

SUPER  
ABRASIVES

DIAMOND  
TOOLS

CLEANING,  
POLISHING  
& MASKING

PERSONAL  
PROTECTION  
EQUIPMENT

TECHNICAL  
INFORMATION



### SPEC CHECK

How to mount the disc in the pad?

- SPEEDLOK DISCS TS ATTACHMENT [Type 2 – SL2]  
A turn-on/turn-off style fastener
- SPEEDLOK DISCS TR ATTACHMENT [Type 3 – SL3]  
Twist on & twist off in 2-½ turns



Avoid gouging on contours by using a smaller size holder than the diameter of the discs, such as 38mm holder for 50mm.



Select a hard back-up pad for higher aggressiveness.



MEDIUM BACK-UP PAD

HARD BACK-UP PAD



# BLENDING

Unique compacted structure design offers material removal while imparting a final smear free finish. Ideal for deburring, edge breaking, blending, cleaning and polishing. Durable construction for fast, economical surface preparation. Can be used in sequence with, fibre and flap discs, to de-burr, blend and impart great finishes in one or two operations.

## APPLICATIONS & MARKETS

- Conditioning grindlines
- Blending surface defects
- Deburring and radiusing edges
- Light stock removal



COATED  
ABRASIVES  
& BEARTEX

BONDED  
ABRASIVES

SUPER  
ABRASIVES

DIAMOND  
TOOLS

CLEANING,  
POLISHING  
& MASKING

PERSONAL  
PROTECTION  
EQUIPMENT

TECHNICAL  
INFORMATION

BETTER ++++

## VORTEX RAPID BLEND OPEN STRUCTURE

**VORTEX**  
RAPID BLEND

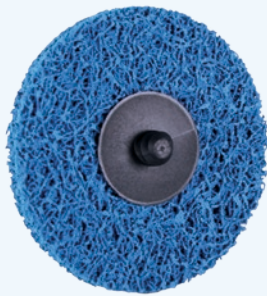

This state-of-the-art product is made of a very open web structure of nylon fibers impregnated with patented grain technology and an advanced resin system. With amazing durability it can work on different deburring, blending and finishing applications.

### FEATURES



- Advanced grain technology
- Longer life (5 to 8 times of competitors)
- Blend in 3D
- Open web structure

### BENEFITS

- Controlled cut rate with consistent finish
- Less disc changes and downtime, improved costs
- Face, edge and backside of the disc can be used, operator friendly and no smearing!
- Avoid premature loading - especially good on soft metals e.g. aluminium, brass etc.



VIDEO LINK

TYPE	DIA (mm)	CAP CODE	GRADE	MAX RPM	PK QTY	ART. NO.
TR 	25	U2311	Medium	35100	100	66254497806
	38	U2311	Medium	30100	80	66254497807
	50	U2311	Medium	22000	25	66254497067
	75	U2311	Medium	18000	25	66254497068
TS 	50	U2311	Medium	22000	25	66254497070*
	75	U2311	Medium	18000	25	66254497069*

\* Made-to-order



## VORTEX RAPID BLEND CLOSED STRUCTURE



High-performance engineered grain provides an aggressive cut and the advanced resin bond system results in the longest wheel life, with up to two times the number of pieces finished per wheel.

### FEATURES

- High-performance engineered grain and improved resin bond system
- Thick nylon web
- New curing process and bond technology
- Excellent form holding

### BENEFITS

- Fast stock removal, reduced cycle time, increased part quality
- Consistent performance, improved part quality, no chemical odour or smearing
- Will not break down under heavy deburring conditions
- Use on a variety of shapes & contours

TYPE	DIAxT (mm)	CAP CODE	GRADE	MAX RPM	PK QTY	ART. NO.
TR 	50x6	U2305	3AM	22000	60	66254428237
	75x3	U2305	5AM	18000	40	66261093556
		U2305	7AM	18000	40	66261090909
	75x6	U2305	3AM	18000	40	66254428238
		U2305	5AM	18000	40	66254413661
		U2305	7AM	18000	40	66254406395

**Dimensions Key:** DIA = Diameter

COATED  
ABRASIVES  
& BEARTEX

BONDED  
ABRASIVES

SUPER  
ABRASIVES

DIAMOND  
TOOLS

CLEANING,  
POLISHING  
& MASKING

PERSONAL  
PROTECTION  
EQUIPMENT

TECHNICAL  
INFORMATION

# RAPID BLEND

NEX

GOOD +++

**Rapid**  
BLEND



Unitized discs are used widely in the preparation of metal surfaces. Excellent for light deburring of flashing & threads, blending alloys, polishing & finishing.

## FEATURES

- Easily preformed
- Holds shape well
- New light density formulation in 2SF and 3SF

## BENEFITS

- Use on a wide variety of contours
- No undercutting or gouging the work piece
- Optimum combination of cut, life & finish with smear resistant properties

DIM DIA (mm)	CAP CODE	GRADE	MAX RPM	PK QTY	ART. NO.
50	U2301	2 A Medium	22000	10	63642585684
	U2301	6 A Medium	22000	10	63642585725
	U4401	2 S Fine	22000	10	63642585677
	U4401	3 S Fine	22000	10	66254473613
	U4401	4 A Fine	22000	10	63642585679
75	U2301	2 A Medium	18000	10	63642585697
	U2301	6 A Medium	18000	10	63642585726
	U4401	3 S Fine	15000	10	66254473614
	U4401	2 S Fine	15000	10	63642585691
	U2401	4 A Fine	15000	10	63642585695



# SURFACE PREPARATION

Surface blending products are reinforced with a special nylon fibre net backing (scrim) to increase the resistance to tearing. They provide a unique combination of aggressive performance, long life and improved finish.

## APPLICATIONS & MARKETS

- Removing surface defects
- Removing light edge burrs, parting lines or flashing
- Removing rust, oxides, corrosion, paints & scale
- Cleaning moulds
- Blending mill marks, tool marks, uneven edges & coated abrasive finish



COATED  
ABRASIVES  
& BEARTEX

BONDED  
ABRASIVES

SUPER  
ABRASIVES

DIAMOND  
TOOLS

CLEANING,  
POLISHING  
& MASKING

PERSONAL  
PROTECTION  
EQUIPMENT

TECHNICAL  
INFORMATION

BETTER ++++

## VORTEX RAPID PREP SCM





### FEATURES

- New resin system & proprietary Vortex grain
- New coating technology
- Combine the cutting speed of coarse grits with the finish of fine grits
- Reduce process time by 50%+
- More resistant to edge wear

### BENEFITS

- Smear free, does not load on aluminium or soft metals
- Thick layer of grain extends product life
- Lowest total cost of consumable tooling per workpiece
- Eliminate 2 to 5 grit sequences to 1 step
- Has up to 4x longer life vs. competitor products

DIA (mm)	CAP CODE	GRADE	PK QTY	TR 	TS 
50	S2103	Extra Coarse	50	66623378336	
	S2203	Coarse	50	66623378340	66623378349
	S2303	Medium	50	66623378342	66623378351
	S2403	Fine	50	66623378345	
	S2503	Very Fine	50	66623378347	66623378353
75	S2103	Extra Coarse	25	66623378337	
	S2203	Coarse	25	66623378341	66623378350
	S2303	Medium	25	66623378343	66623378352
	S2403	Fine	25	66623378346	
	S2503	Very Fine	25	66623378348	66623378354

Dimensions Key: DIA = Diameter



## RAPID PREP

AO SCM

GOOD +++

**Rapid**  
**PREP**





### FEATURES

- Open structure
- High abrasive content
- Flexible backing
- General purpose

### BENEFITS

- Resists loading on softer materials
- Fast initial cut rate
- Conforms to surface contours
- Very versatile

DIA (mm)	CAP CODE	GRADE	PK QTY	TR 	TS 
25	S2108	Extra Coarse	50		
	S2208	Coarse	50	66623378357	
	S2308	Medium	50	66623378361	
	S2508	Very Fine	50	66623378380	
38	S2108	Extra Coarse	50		
	S2208	Coarse	50	66623378358	
	S2308	Medium	50	66623378362	
	S2508	Very Fine	50	66623378371	
50	S2108	Extra Coarse	50	66623378355	
	S2208	Coarse	50	66623378359	66623378374
	S2308	Medium	50	66623378363	66623378376
	S2408	Fine	50	66623378366	
75	S2508	Very Fine	50	66623378372	66623378378
	S2108	Extra Coarse	25	66623378356	
	S2208	Coarse	25	66623378360	66623378375
	S2308	Medium	25	66623378364	66623378377
	S2408	Fine	25	66623378382	
	S2508	Very Fine	25	66623378373	66623378379

Other sizes and grades available MTO

## RAPID PREP

SPEEDLOK TEST KITS



KIT	PK QTY	ART. NO.
Vortex RapidPrep TR 75mm	1 x 5 discs	66623386185
RapidPrep TR 75mm	1 x 5 discs	66623386186
Vortex RapidPrep TR 50mm	1 x 5 discs	66623386187
RapidPrep TR 50mm	1 x 5 discs	66623386188

Each Kit comprises of 5 discs:

GRADE	COLOUR	KIT QTY
Extra Coarse	Black	1
Coarse	Brown	1
Medium	Maroon	1
Fine	Green	1
Very Fine	Blue	1



## HIGH STRENGTH DISC



Provides an excellent finish and flexibility with greater tear resistance.

### FEATURES

- Premium aluminium oxide grain
- Firm, durable web
- Strong resin binders
- Smear-proof

### BENEFITS

- Clean cutting & long lasting
- High resistance to tearing on burrs & sharp edges
- Highly smear-resistant
- Produces a satin finish

DIA (mm)	CAP CODE	GRADE	PK QTY	TR 
50	F2303	Medium A	50	63642585924
	F2506	Very Fine A	50	08834163987
75	F2303	Medium A	50	08834164065
	F2506	Very Fine A	50	63642585932

## HIGH-STRENGTH CROSS BUFFS



### FEATURES

- Unique design with a durable non-woven construction
- Removing oxidation and preparing surfaces prior to coating aircraft parts

### BENEFITS

- Longer life and cool running
- ID grinding and finishing

DIAxT (mm)	GRADE	PK QTY	ART. NO.
38x13	Medium	100	08834189308*
38x13	Very fine	100	08834189307*
Mandrel MM32-4**		1	63642587136*

\*\* Use Mandrel MM32-4 to mount 38mm Cross Buffs

\* Made-to-order

**Dimensions Key:** DIA = Diameter, T = Thickness

COATED  
ABRASIVES  
& BEARTEX

BONDED  
ABRASIVES

SUPER  
ABRASIVES

DIAMOND  
TOOLS

CLEANING,  
POLISHING  
& MASKING

PERSONAL  
PROTECTION  
EQUIPMENT

TECHNICAL  
INFORMATION

# STRIPPING & CLEANING

Rapid Strip discs are constructed with thick, strong, synthetic fibres and extra-coarse silicon carbide abrasive. The open web construction of the disc provides fast cutting action with very little loading. Safer than wire bristle tools, Rapid Strip is suitable for use in many industries.

## APPLICATIONS & MARKETS

- Removal of surface rust & residue, corrosion, light weld splatter, dirt, mill scale & other similar surface contaminants
- Paint & epoxy coating removal
- Surface preparation before applying coatings
- Surface preparation before welding
- Cleaning & conditioning after welding



COATED  
ABRASIVES  
& BEARTEX

BONDED  
ABRASIVES

SUPER  
ABRASIVES

DIAMOND  
TOOLS

CLEANING,  
POLISHING  
& MASKING

PERSONAL  
PROTECTION  
EQUIPMENT

TECHNICAL  
INFORMATION

BEST +++++

## BLAZE RAPID STRIP





### FEATURES

- Heavy coating of Norton SG Blaze ceramic alumina long-lasting grain and advanced resin bond
- Extremely versatile; use one disc for multiple operations
- Open structure

### BENEFITS

- Last 2x longer than competitors
- Will not shed on rust-encrusted pieces, or load on soft metals
- Lighter pressure will finish similar to a medium grit surface conditioning disc; additional pressure will remove material (strip and clean)
- Less downtime, and less production waste/landfill scrap

DIA (mm)	CAP CODE	GRADE	MAX RPM	PK QTY	TR 	TR+ 
50	R9101	X Coarse SG	20000	25	66623303912	
75	R9101	X Coarse SG	15000	25	66261096557	
100	R9101	X Coarse SG	8000	5		66623303921

Use with TR+ Holder



# RAPID STRIP

**GOOD +++**





### FEATURES

- Open web construction
- Conformable
- Thick, strong, synthetic fibres & extra coarse grit
- New 100mm TR+ discs available
- Strippa version also available

### BENEFITS

- Fast cutting & long lasting
- Follow difficult part profiles
- Easy cleaning of uneven surfaces
- Quick cleaning & conditioning of surfaces with aggressive corrosion removal
- Quick-change replacement; can be used on face & edge

DIA (mm)	CAP CODE	GRADE	MAX RPM	PK QTY	TR  RAPID STRIP	TR  STRIPPA	TR+  RAPID STRIP
50	R4101	X Coarse S	20000	10	63642588173	63642556605	
75	R4101	X Coarse S	15000	10	63642588175	63642556624	
100	R4101	X Coarse S	8000	5			63642585751

Use with TR+ Holder

**Dimensions Key:** DIA = Diameter

COATED ABRASIVES & BEARTEX

BONDED ABRASIVES

SUPER ABRASIVES

DIAMOND TOOLS

CLEANING, POLISHING & MASKING

PERSONAL PROTECTION EQUIPMENT

TECHNICAL INFORMATION



# POLISHING

Polishing is the final stage in the process, to achieve a glossy, high shine finish.

- Use on all metals including stainless steel & aluminium
- Remove fine scratches
- Impart a high quality mirror shine



COATED  
ABRASIVES  
& BEARTEX

BONDED  
ABRASIVES

SUPER  
ABRASIVES

DIAMOND  
TOOLS

CLEANING,  
POLISHING  
& MASKING

PERSONAL  
PROTECTION  
EQUIPMENT

TECHNICAL  
INFORMATION

## RAPID POLISH

GOOD +++

**Rapid**  
POLISH



### FEATURES

- Ideal for use with polishing compounds to give final finish
- 50mm & 75mm diameter size available

### BENEFITS

- Achieves spectacular results on a variety of metals such as stainless steel & aluminium
- Excellent for polishing small areas achieving a good cosmetic finish

DIA (mm)	GRADE	PK QTY	TR 
50	Felt	25	63642587165
75	Felt	25	63642587167

## APPLICATION GUIDE

INDUSTRY	APPLICATION	PRODUCTS
Aerospace maintenance	<ul style="list-style-type: none"> <li>• Removing coatings</li> <li>• Cleaning weld lines in awkward areas</li> <li>• Maintenance work on fuselage &amp; wings</li> </ul>	Rapid Prep surface blending discs
Marine	<ul style="list-style-type: none"> <li>• Cleaning hulls, finishing aluminium casings</li> </ul>	Rapid Strip & coarse Rapid Prep surface blending discs
Automotive	<ul style="list-style-type: none"> <li>• Accessing hard to reach areas such as under the bonnet &amp; door frames ideal for removing stone chips</li> </ul>	Rapid Strip & coarse Rapid Prep surface blending discs
Composites	<ul style="list-style-type: none"> <li>• Removal of squeezed excessive glue</li> </ul>	Unitized & Rapid Prep surface blending discs
Wood	<ul style="list-style-type: none"> <li>• Removal of old paint &amp; coatings</li> </ul>	Rapid Strip & Rapid Prep surface blending discs
Food processing	<ul style="list-style-type: none"> <li>• Surface finishing</li> </ul>	Rapid Prep surface blending discs
Architectural steelwork	<ul style="list-style-type: none"> <li>• Cleaning &amp; finishing weld joints</li> <li>• Achieving decorative finishes</li> </ul>	Unitized & Rapid Prep surface blending discs



**SPEEDLOK KIT TR ATTACHMENT (TYPE 3 – SL3)**



SPEED-LOK TR – 63642588233

TYPE	DIA (mm)	GRIT/ GRADE DENSITY	PK QTY
GREENLYTE PLUS F986	50	36	2
	50	60	2
SG CERAMIC R981	50	36	2
	50	60	2
NORZON HEAVY DUTY	50	36	2
	50	60	2
NORZON R822	50	36	2
	50	60	2
	50	80	2
R230	50	36	2
	50	60	2
	50	80	2
	50	120	2
ALOX RV81	50	36	2
	50	60	2
SURFACE BLENDING BEARTEX	50	Coarse	2
	50	Fine	2
	50	Very Fine	2
UNITIZED	50	Fine	1
STRIPPA	50	Coarse	1
RUBBER BACK-UP PAD	50	Medium	1

**SPEEDLOK KIT TS ATTACHMENT (TYPE 2 – SL2)**



SPEED-LOK TS – 63642588234

TYPE	DIA (mm)	GRIT/ GRADE DENSITY	PK QTY
GREENLYTE PLUS F986	50	36	2
	50	50	2
SG CERAMIC R981	50	36	2
	50	50	2
NORZON HEAVY DUTY	50	36	2
	50	50	2
	50	80	2
ALOX RV81	50	120	2
	50	36	2
	50	60	2
ALOX RV71	50	36	2
	50	60	2
	50	80	2
	50	120	2
SURFACE BLENDING BEARTEX	50	Coarse	2
	50	Medium	2
	50	Very Fine	2
RUBBER BACK-UP PAD	50	Medium	1

Dimensions Key: DIA = Diameter

COATED ABRASIVES & BEARTEX

BONDED ABRASIVES

SUPER ABRASIVES

DIAMOND TOOLS

CLEANING, POLISHING & MASKING

PERSONAL PROTECTION EQUIPMENT

TECHNICAL INFORMATION

# BACK-UP PADS FOR SPEEDLOK DISCS

## POWER TOOL: MINI ANGLE GRINDER



### BACK-UP PADS TR ATTACHMENT (Type 3 – SL3)



TYPE	DIA (mm)	DENSITY		MAX RPM	PK QTY
		MEDIUM	HARD		
RUBBER BACK-UP PAD WITH 6mm SPINDLE	25	63642556628		38100	1
	38	63642556629		25100	1
	50	07660717817	63642586931	19000	1
	75	63642556631	66254401460	12800	1



### BACK-UP PADS TS ATTACHMENT (Type 2 – SL2)



TYPE	DIA (mm)	DENSITY		MAX RPM	PK QTY
		MEDIUM	HARD		
RUBBER BACK-UP PAD WITH 6mm SPINDLE	15	66254401994		38100	1
	25	07660718963		38100	1
	38	07660707032		25100	1
	50	63642501157	63642586926	19000	1
	75	07660707384	63642586932	12800	1



#### SPEC CHECK

- Avoid gouging on contours by using a smaller size holder than the diameter of the discs, such as 38mm holder for 50mm.
- Select a hard back-up pad for higher aggressiveness.



## POWER TOOL: STRAIGHT GRINDER OR DRILL



### BACK-UP PADS TR+ ATTACHMENT (TR+ – SL4)



TYPE	DENSITY		MAX RPM	PK QTY
	HARD			
PLASTIC BACK-UP PAD WITH 6mm SPINDLE	63642586196		15000	1



Just for 100mm Speedlok TR+ discs

COATED ABRASIVES & BEARTEX

BONDED ABRASIVES

SUPER ABRASIVES

DIAMOND TOOLS

CLEANING, POLISHING & MASKING

PERSONAL PROTECTION EQUIPMENT

TECHNICAL INFORMATION



## POWER TOOL: ANGLE GRINDER



## BACK-UP PADS

TYPE	DENSITY		MAX RPM	PK QTY
	MEDIUM RUBBER	HARD BLUE NYLON		
BACK-UP PAD WITH M14 THREAD	63642587305	63642557133	11200	1



## ADAPTORS

TYPE	METAL	MAX RPM	PK QTY
ADAPTOR M14 - 1/4"	63642587997	12000	1



Female M14, male thread 1/4 - 20 UNC. Suitable for all rubber back-up pads.

**Dimensions Key:** DIA = Diameter



### SPEC CHECK

Remove the metallic spindle and screw the adaptor to use the rubber back-up directly on the angle grinder.

Adapt your 3/8-24 or 5/8-11 right angle grinder to a Type II or Type III back-up pad.

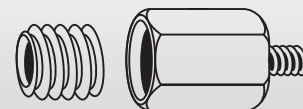

Size	CLOTH ABRASIVE DISCS MAXIMUM SPEED - RPM	NON WOVEN RAPIDPREP SCM DISCS MAXIMUM SPEED - RPM
19mm Diameter	38100	30000
25mm Diameter	38100	30000
38mm Diameter	25100	25100
50mm Diameter	19000	19000
75mm Diameter	12800	12800

COATED  
ABRASIVES  
& BEARTEX

BONDED  
ABRASIVES

SUPER  
ABRASIVES

DIAMOND  
TOOLS

CLEANING,  
POLISHING  
& MASKING

PERSONAL  
PROTECTION  
EQUIPMENT

TECHNICAL  
INFORMATION





# 141-170 DIE GRINDER



COATED  
ABRASIVES  
& BEARTEX

BONDED  
ABRASIVES

SUPER  
ABRASIVES

DIAMOND  
TOOLS

CLEANING,  
POLISHING  
& MASKING

PERSONAL  
PROTECTION  
EQUIPMENT

TECHNICAL  
INFORMATION

142 Spindle Mounted  
Flap Wheels  
Specialties

165 Rapid Blend  
Unitised Wheels

169 Accessories  
for Die Grinder

# FLAP WHEELS WITH SPINDLE

Flap wheels are conformable to intricate shapes and contours. Designed to deliver a consistent finish with a uniform rate of cut, flap wheels wear away evenly and without residue, continually exposing fresh abrasives.

Wheels are designed with a 3 or 6mm steel shank as an integral part of each wheel. These shanks run through the wheel creating better balance, a reduction of chatter, and reduced operator fatigue. They also permit quick changes on air tools when using other abrasive products.

Flap wheels with shaft achieve their best performance at a recommended speed of 15-25m/s.

Optimizing stock removal, surface finish, thermal load of the workpiece and toll wear.

## APPLICATIONS & MARKETS

- Blending, deburring and finishing
- Metal fabrication, welding and polishing
- For straight shaft grinders or drilling machines



## SHAPE RECOMMENDATION GUIDE

### STANDARD FLAP WHEEL

Ranging from 15 to 80mm diameter mounted on a 6 diameter steel shaft and for the very small diameters (<=30mm) also available as 3mm shaft as optional. Shaft length of 40mm.

Very durable, long-lasting flap wheels for demanding, heavy stock removal applications.



### SLOTTED FLAP WHEELS

Available in diameters from 30 to 80mm with a 6mm fixing spindle and a shaft length of 40mm.

The additional slots on the flaps improve the flexibility making it much more comfortable to use, reaching difficult-to-access areas and quickly profiles to complex contour of the workpiece.



#### SPEC CHECK

To prevent unnecessary tool wear do not increase the contact pressure too much, the increase of stock removal should be achieved by using a coarser grit size.

To get a slightly finer surface increase the cutting speed.

To get a slightly rougher finishing increase the contact pressure.

Using same grit size, the finishing is rougher on softer materials.

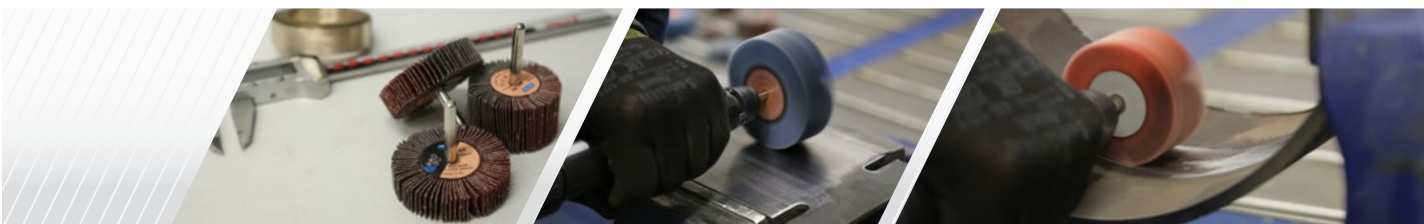

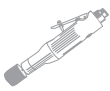

# STANDARD FLAP WHEELS

X-TREME R822

BETTER ++++

**X-TREME**



The BETTER choice for stainless steel and resistant alloys.

**FEATURES**

- Premium, self-sharpening zirconia alumina grain
- Heavy cotton backing

**BENEFITS**

- For aggressive and quick operation
- Ideal for grinding, shaping, blending, edge breaking & weld
- High & regular cut rate

DIM DIAxWxS (mm)	GRIT			RECOMMEND SPEED (RPM)	PK QTY
	P40	P60	P80		
30x20x6	66261033325	66261139984	66261139986	9500 - 15900	10
40x20x6	63642578194	63642578195	63642578196	7100 - 12000	10
50x20x6	66261139987	63642578221	63642578222	5700 - 9500	10
60x30x6	63642539952	63642536547	63642539953	4800 - 7900	10
80x30x6	63642539954	63642539955	63642536548	3600 - 6000	10
80x50x6	63642578252	63642578253	63642578254	3600 - 6000	10

Other grits and sizes available upon request.

**Dimensions Key:** DIM = Dimensions, DIA = Diameter, W = Width, S = Spindle

COATED  
ABRASIVES  
& BEARTEX

BONDED  
ABRASIVES

SUPER  
ABRASIVES

DIAMOND  
TOOLS

CLEANING,  
POLISHING  
& MASKING

PERSONAL  
PROTECTION  
EQUIPMENT

TECHNICAL  
INFORMATION



# X-TREME R427



The BETTER choice for hard and tough materials e.g. titanium and ideally for work on copper, bronze, brass, non-ferrous materials, stone, glass and plastic.

### FEATURES

- Sharp silicon carbide abrasive
- Flexible cotton cloth

### BENEFITS

- For high initial cut and penetration for brass and nonferrous materials
- Ideal solution for titanium and non-ferrous aircraft and engine parts grinding
- Conformable to irregular shaped components and contours

DIM DIAxWxS (mm)	GRIT						RECOMMEND SPEED (RPM)	PK QTY
	P60	P80	P120	P180	P220	P320		
20x10x3	66261128665	66261128667	66261128668	66261128671	66261128672	66261128673	14300 - 23900	10
20x20x6	66261126592	66261126593	66261126598	66261126603	66261126604	66261126605	14300 - 23900	10
30x10x6	66261127026	66261127027	66261127028	66261127030	66261127031	66261127032	9500 - 15900	10
30x20x6	66261127034	66261127035	66261127036	66261127038	66261127039	66261127040	9500 - 15900	10
40x10x6	66261127109	66261127111	66261127112	66261127115	66261127117	66261127118	7100 - 12000	10
40x20x6	66261127119	66261127120	66261127122	66261127125	66261127126	66261127127	7100 - 12000	10
50x10x6	66261127134	66261127135	66261127136	66261127140	66261127141	66261127148	5700 - 9500	10
50x30x6	66261127246	66261127247	66261127248	66261127252	66261127253	66261127254	5700 - 9500	10
60x15x6	66261127257	66261127258	66261127259	66261127261	66261127262	66261127263	4800 - 7900	10
60x30x6	66261127264	66261127265	66261127266	66261127272	66261127273	66261127274	4800 - 7900	10
80x30x6	66261127405	66261127406	66261127407	66261127409	66261127410	66261127412	3600 - 6000	10

Other grits and sizes available upon request.

COATED  
ABRASIVES  
& BEARTEX

BONDED  
ABRASIVES

SUPER  
ABRASIVES

DIAMOND  
TOOLS

CLEANING,  
POLISHING  
& MASKING

PERSONAL  
PROTECTION  
EQUIPMENT

TECHNICAL  
INFORMATION

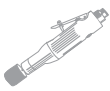

BDX R207

**GOOD +++**

**BDX**

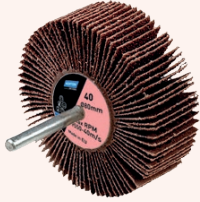

The GOOD choice where a superior finish is required or on low-pressure applications. Universal product for steel and stainless steel materials.

**FEATURES**

- Premium aluminum oxide grain
- Flexible cotton backing

**BENEFITS**

- For aggressive cut and longer life
- Excellent cut rate on low-pressure finishing operations with ability to leave a very good finish
- Conformable to the workpiece

**FLAP WHEELS WITH 3mm SHAFT**

DIM DIAxWxS (mm)	GRIT					RECOMMEND SPEED (RPM)	PK QTY
	P60	P80	P120	P180	P320		
15x15x3	66261139936	66261139944	66261139945	66261139947	66261139948	19000 - 31800	10
20x5x3	66261139949	66254405766	66261139955	66261139958	66261139959	14300 - 23900	10
20x10x3	66261139960	66261139962	66261139964	66261139966	66261139967	14300 - 23900	10
30x5x3	66254403825	66261077731	66261138285	66261139972	66261139973	9500 - 15900	10
30x10x3	66261139974	66261135391	66261139976	66261139978	66261135146	9500 - 15900	10

Other grits and sizes available on request.

**Dimensions Key:** DIM = Dimensions, DIA = Diameter, W = Width, S = Spindle

COATED  
ABRASIVES  
& BEARTEX

BONDED  
ABRASIVES

SUPER  
ABRASIVES

DIAMOND  
TOOLS

CLEANING,  
POLISHING  
& MASKING

PERSONAL  
PROTECTION  
EQUIPMENT

TECHNICAL  
INFORMATION

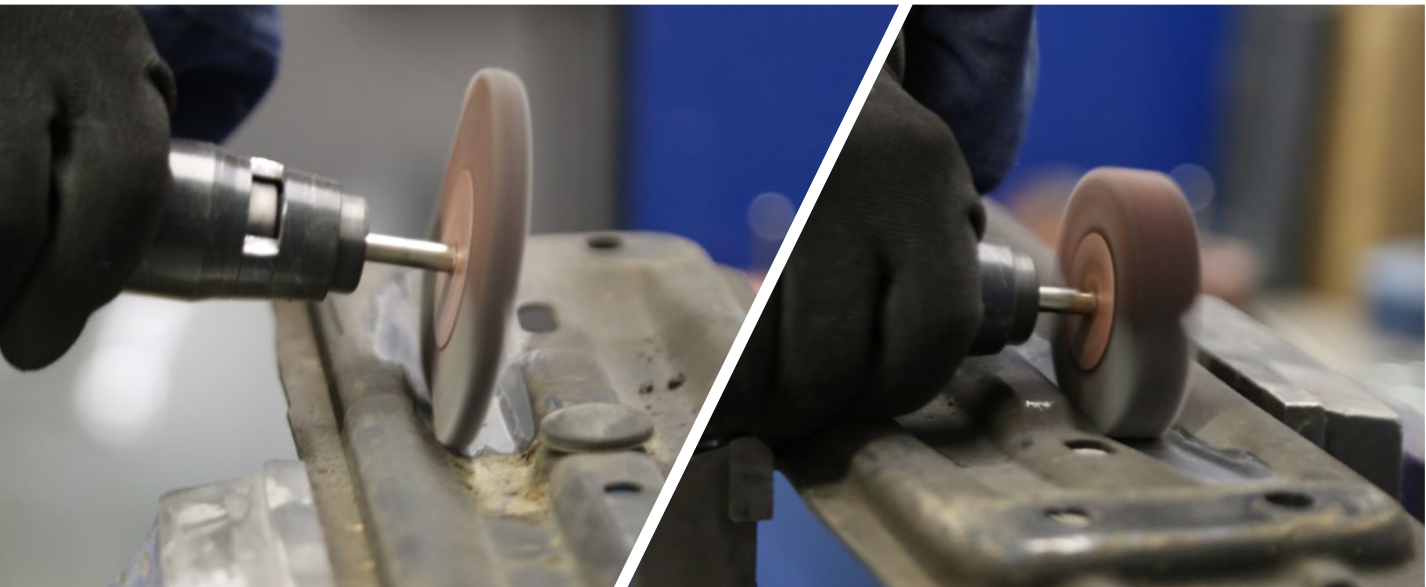

# BDX R207

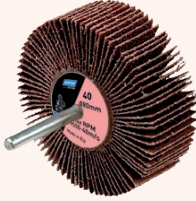

The GOOD choice where a superior finish is required or on low-pressure applications. Universal product for steel and stainless steel materials.

### FEATURES

- Premium aluminum oxide grain
- Flexible cotton backing

### BENEFITS

- For aggressive cut and longer life
- Excellent cut rate on low-pressure finishing operations with ability to leave a very good finish
- Conformable to the workpiece

## FLAP WHEELS WITH 6mm SHAFT

DIM DIAxWxS (mm)	GRIT							RECOMMEND SPEED (RPM)	PK QTY
	P40	P60	P80	P120	P180	P240	P320		
20x10x6	77696007699	66261193703	66623329045	66261137904	66623375122	66261137914	66261137915	14300 - 23900	10
25x20x6	66261100608	66261106190	77696086608	66261137918	66261138088	66261138089	66261138091	11500 - 19000	10
30x5x6	66261138093	66254403825	66261077731	66261138094	66261077809	66261138096	66261135495	9500 - 15900	10
30x10x6	66261138103	63642545207	63642537371	63642552728	66261138104	63642545208	66261135215	9500 - 15900	10
30x15x6	66261056890	63642513148	63642561466	63642551593	66261138106	63642547341	63642513149	9500 - 15900	10
30x30x6	66261138108	66254410858	66261063210	66261138109	66623331386	66261138112	66261138113	9500 - 15900	10
40x10x6	66261138183	69957360891	69957360892	66261138186	66261138187	66261138188	66261138189	7100 - 12000	10
40x15x6	63642539937	63642533099	63642533098	63642533094	66261138192	69957360895	66261135220	7100 - 12000	10
40x20x6	63642539938	63642546771	63642546768	63642546760	66261066179	63642539939	63642539940	7100 - 12000	10
50x10x6	66261138193	66261138194	66261138196	66261138268	66261138270	66261138272	66261138273	5700 - 9500	10
50x20x6	63642546774	63642531870	63642533097	63642546759	66261138275	63642546724	63642539942	5700 - 9500	10
50x30x6	63642539943	63642534251	63642561879	63642531863	66261136117	66261138276	63642546725	5700 - 9500	10
60x15x6	63642546773	69957360901	63642546767	63642546758	66261138277	69957360903	63642539945	4800 - 7900	10
60x20x6	63642536738	63642531869	63642531866	63642531862	66261138279	63642539770	66261135389	4800 - 7900	10
60x30x6	63642536737	63642531868	63642531865	63642531861	66261090663	63642546694	63642546727	4800 - 7900	10
60x40x6	66261138280	66261056891	66261056892	66261056893	66261138281	66261138282	66261135390	4800 - 7900	10
80x30x6	69957360911	63642531867	63642533096	63642534250	66261138283	63642545895	63642561901	3600 - 6000	10
80x50x6	69957360914	63642559718	69957360916	69957360917	66261138284	63642539948	66261135498	3600 - 6000	10

Other grits and sizes available upon request.

COATED  
ABRASIVES  
& BEARTEX

BONDED  
ABRASIVES

SUPER  
ABRASIVES

DIAMOND  
TOOLS

CLEANING,  
POLISHING  
& MASKING

PERSONAL  
PROTECTION  
EQUIPMENT

TECHNICAL  
INFORMATION

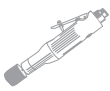

# SLOTTED FLAP WHEELS

BDX R207

GOOD +++

**BDX**

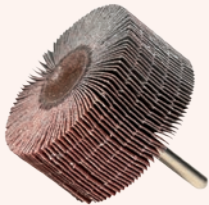

The GOOD choice where superior finish is required or on low-pressure applications. Universal product for steel and stainless steel materials. The additional slots on the flaps improve the flexibility making it much more comfortable to use, reaching difficult-to-access areas and quickly profiles to complex contour of the workpiece.

### FEATURES

- Premium aluminum oxide grain
- Flexible cotton backing
- Slotted flaps

### BENEFITS

- For aggressive cut and longer life
- Excellent cut rate on low-pressure finishing operations with ability to leave a very good finish
- Conformable to the workpiece
- Improve the flexibility making flaps much more comfortable to use, reaching difficult-to-access areas

DIM DIAxWxS (mm)	GRIT					RECOMMEND SPEED (RPM)	PK QTY
	P40	P80	P120	P220	P320		
30x15x6	66261135702	66261135714	66261135730	66261135732	66261135745	9500 - 15900	10
40x20x6	66261135775	66261135779	66261135782	66261135784	66261135785	7100 - 12000	10
60x30x6	66261135790	66261135792	66261135794	66261135795	66261135796	4800 - 7900	10
80x50x6	66261135797	66261135799	66261135801	66261135803	66261135804	3600 - 6000	10

Other grits and sizes available upon request.

**Dimensions Key:** DIM = Dimensions, DIA = Diameter, W = Width, S = Spindle

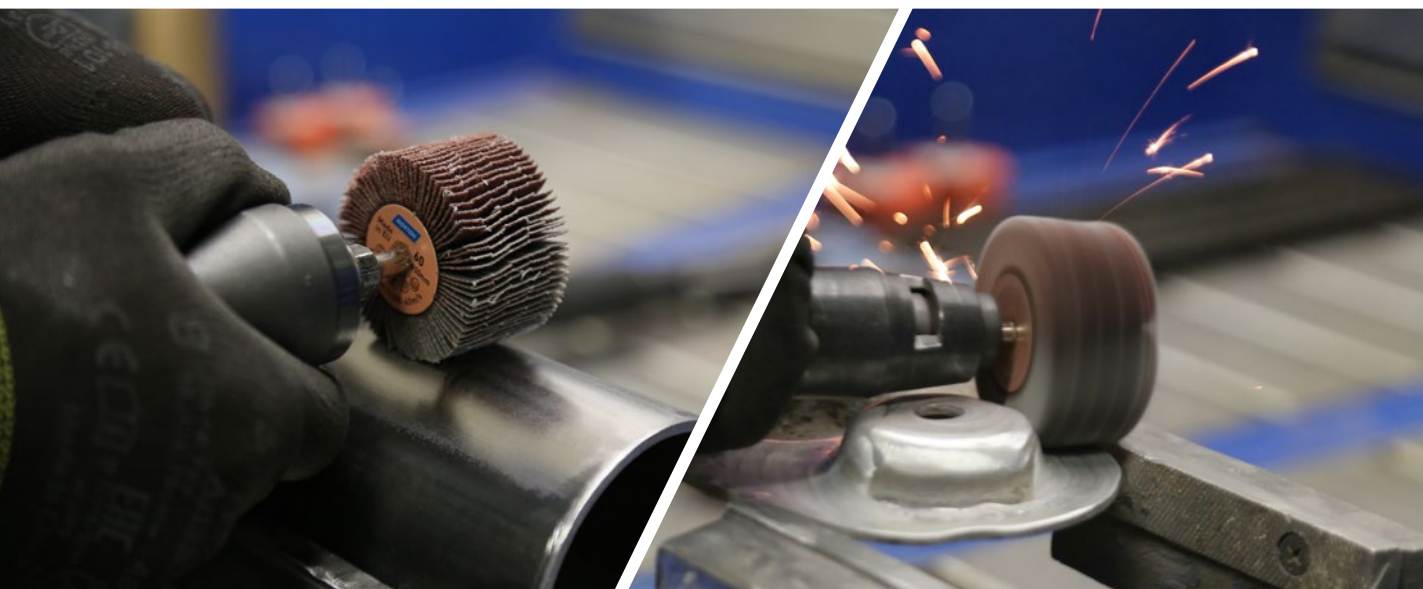

COATED  
ABRASIVES  
& BEARTEX

BONDED  
ABRASIVES

SUPER  
ABRASIVES

DIAMOND  
TOOLS

CLEANING,  
POLISHING  
& MASKING

PERSONAL  
PROTECTION  
EQUIPMENT

TECHNICAL  
INFORMATION



## PRODUCT SELECTION GUIDE

MATERIALS / APPLICATIONS	HIGHLY RECOMMENDED	RECOMMENDED
Stainless Steel/Heat Sensitive Alloys	R822	R207
Carbon Steel/Weld/Ferrous metal	R207	
Non-ferrous metal/brass	R427	

MATERIALS / APPLICATIONS	DEBURRING	CLEANING	BLEND/FINISH
Metal	F2302	F2401	F4300/F2501
Wood	F2300	F2401	F2501

## SPINDLE MOUNTED RECOMMENDED OPERATING SPEED

DIM DIAxWxS(mm)	RECOMMENDED MAXIMUM RPM
30x15x6	25500
30x20x6	25500
40x20x6	19100
50x20x6	15300
50x30x6	15300
60x15x6	12700
60x30x6	12700
60x40x6	12700
80x50x6	9600

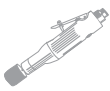

# BEARTEX SPINDLE MOUNTED FLAP WHEELS

## FLAP WHEEL TYPES

### BearTex Non Woven Flap wheels

Mounted on a 6mm diameter spindle, designed to be used on straight line die grinders for removal of oxidation, paint, corrosion and generating grain finishes.

Ideal for finishing large and awkward components.

Can be used for metals, wood, composite and plastics.

Less aggressive than conventional coated abrasive flapwheels.



### BearTex Interleaved Flap Wheels

Interleaved version gives the benefits of aggressiveness by alternatively arranging coated abrasive cloth with the finishing qualities of Non wovens.

They are soft and aggressive, creating a "firmer" wheel that provides a higher rate of cut.

The ratio of Cloth flaps to non woven flaps can be altered to suit particular applications.

Ideal for deburring and grain finishing on stainless steel.



## BEARTEX FLAP WHEELS HEAVY DUTY

BETTER ++++



### FEATURES

- Heavy Duty addition to range
- Flexible and 3 dimensional conformability
- Premium aluminum oxide grain gives a performance boost
- Enhanced Clean Bond resin coverage

### BENEFITS

- Durable blending and finishing wheels with up to x2 more wheel life
- Can access awkward corners and recesses
- Clean, blend, deburr and finish in record time
- Consistent uniform surface finish, no smearing

## BEARTEX FLAP WHEELS

GOOD +++



### FEATURES

- Cushioning action
- Constructed using layers of BearTex with a smear resistant formula
- Available in a wide range of sizes & grades
- Ventilated flap arrangement

### BENEFITS

- Ideal for use on contoured & shaped surfaces
- Consistent & uniform finish with no risk of gouging
- Suitable for a wide range of applications including corrosion removal, cleaning & surface finishing
- Vibration free for a consistent finish without smearing or component discolouration

COATED  
ABRASIVES  
& BEARTEX

BONDED  
ABRASIVES

SUPER  
ABRASIVES

DIAMOND  
TOOLS

CLEANING,  
POLISHING  
& MASKING

PERSONAL  
PROTECTION  
EQUIPMENT

TECHNICAL  
INFORMATION

## BEARTEX SPINDLE MOUNTED FLAP WHEELS

DIM DxWxS(mm)	GRADE	INTERLEAVED CLOTH GRIT	CAP CODE	PK QTY	BETTER	GOOD
30x20x6	Medium A		F2300	10		66261032155
	Fine A		F2401	10		66261032160
40x20x6	Medium A		F2300	10		66261032156
	Fine A		F2401	10		66261032161
	Very Fine A		F2501	10		66261032165
60x30x6	Fine A Interleaved	60	F2401	10		63642549639
	Fine A Interleaved	100	F2401	10		63642549640
	Fine A Interleaved	150	F2401	10		63642549641
	Coarse		F2202	10		66261032167
	Medium A		F2316	10	66261117932	
	Medium A		F2300	10		66261032157
	Medium S		F4300	10		66261053048
	Fine A		F2401	10		63642549650
60x30x6	Fine S		F4401	10		63642515902
	Very Fine A		F2501	10		63642515905
60x30x6	Medium A		F2316	10	66261117934	
80x50x6	Fine A Interleaved	60	F2401	10		07660705179
	Fine A Interleaved	100	F2401	10		63642515544
	Fine A Interleaved	150	F2401	10		63642515545
	Coarse		F2202	10		63642586113
	Medium S		F4300	10		66261053053
	Fine A		F2401	10		63642515583
	Fine S		F4401	10		63642515614
	Very Fine A		F2501	10		63642515628
100x50x6	Fine A Interleaved	60	F2401	10		63642515907
	Fine A Interleaved	100	F2401	10		63642515908
	Fine A Interleaved	150	F2401	10		63642515909
	Medium A		F2316	5	66261117936	
	Fine A		F2401	10		63642515903
	Fine S		F4401	10		63642515904
	Very Fine A		F2501	10		63642515906

The catalogue includes details of all stock products but other options are available using Norton's made to order facility.

Please contact your local sales or customer service representative for more information.

## BEARTEX TR+ MOUNTED FLAP WHEELS

DIM DxWx ATTACHMENT	GRADE	CAP CODE	PK QTY	BETTER
60x30xTR	Medium A	F2316	10	66261124072

Use with TR+ Holder for quick change capability.  
Also available in interleaf and TR+ in large and small diameter wheels.

**Dimensions Key:** DIM = Dimensions, DIA/D = Diameter, W = Width, S = Spindle



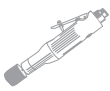

# CARTRIDGE ROLLS

Used on inside surfaces and corners where other abrasive shapes cannot reach and dressing fillet weld seams on metal structures. Typically these are used on high-speed air grinders and are always mounted on a mandrel. Ideal for flash removal, polishing, or removing machine tool marks, and edge breaking.

A compact, lightweight, handheld tool for mandrel-mounted abrasive products that allows for better control than larger die grinders and is a must for any detail work on small parts. Cartridge and Spiral rolls are strips of abrasive cloth rolled and glued to form a solid shape that is designed to break down during use and reveal the next layer of abrasive. Easy to control and to replace due to special mandrel.

Cartridge and Spiral achieve their best performance at a recommended speed of 6-9 m/s. Optimizing stock removal, surface finish, thermal load of the workpiece and tool wear.

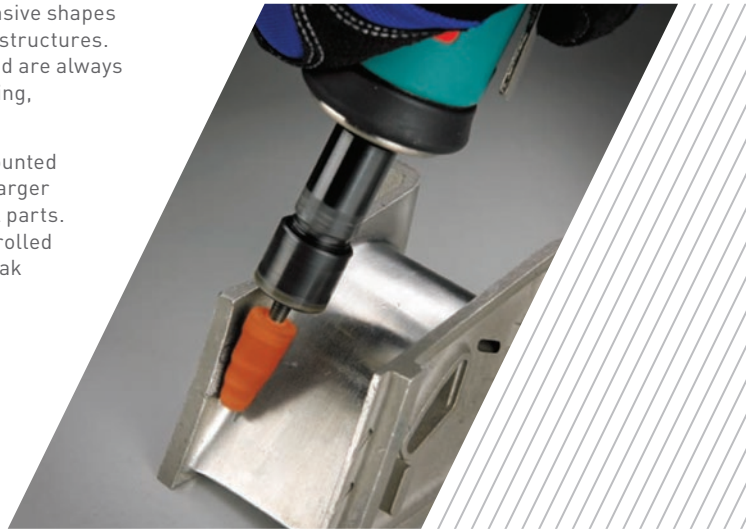

## SHAPE RECOMMENDATION GUIDE

### STRAIGHT ZPE

Straight rolls wear to the shape required.

- Effective for flash removal
- Polishing or removing machine tool marks
- Edge breaking
- Valuable abrasive tool for reaching into corners, where larger diameter tools cannot work

All cartridge roll part numbers shown are resin bond, half-glued.

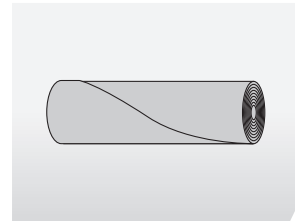

### SPIRAL ZSPI

Spiral rolls are especially suited for use on contoured parts.

Especially useful for grinding/polishing of channels, fillets and radii, and deburring small holes

- Full taper used when the area to finished is hard to reach with a full cartridge roll
- The tapered roll conforms to smaller areas
- Fits into irregular concaves, contours, channels

All spiral roll part numbers shown are full tapered, resin bond, half glued.

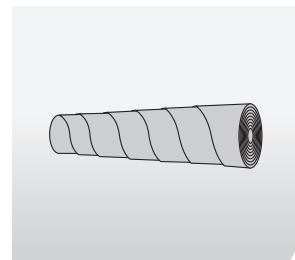

#### SPEC CHECK

- Grind using the tip and not the full surface, to prevent adhesive to be damaged from overheat
- Not permitted for wet grinding

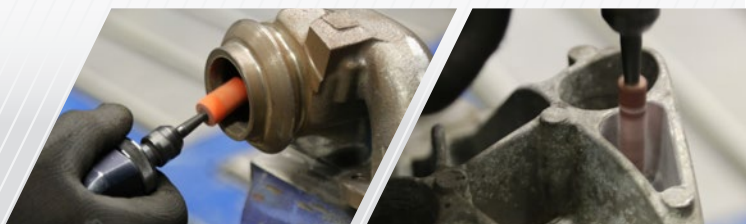

COATED  
ABRASIVES  
& BEARTEX

BONDED  
ABRASIVES

SUPER  
ABRASIVES

DIAMOND  
TOOLS

CLEANING,  
POLISHING  
& MASKING

PERSONAL  
PROTECTION  
EQUIPMENT

TECHNICAL  
INFORMATION



**BLAZE** R920

CARTRIDGE AND SPIRAL ROLL

**BEST +++++****BLAZE**

The BEST choice for hard-to-grind materials, stainless steel, cobalt, inconel and titanium.

**FEATURES**

- Next-generation Ceramic Alumina abrasive grain
- Advanced gridding aid
- Improved resin bond system
- Strong X-weight cotton backing

**BENEFITS**

- Provides greatest productivity with significantly faster cut rates and longer life
- For cooler cut and reduces loading and glazing
- For exceptional grain retention and longer life
- For durability and even wear

**STRAIGHT ZPE**

DIM BSxLxB (mm)	GRIT			RECOMMEND SPEED (RPM)	MANDREL CODE	PK QTY
	60	80	120			
6 x 25 x 3	66261128959	66261128985	66261128994	19000 - 28600	63642556790	50
6 x 38 x 3	66261128965	66261128986	66261128995	19000 - 28600	63642556791	50
10 x 25 x 3	66261128971	66261128987	66261128996	11500 - 17200	63642556790	50
10 x 38 x 3	66261128973	66261128988	66261128997	11500 - 17200	63642556791	50
13 x 25 x 3	66261128974	66261128989	66261128998	8800 - 13200	63642556790	50
13 x 38 x 3	66261128975	66261128990	66261128999	8800 - 13200	63642556791	50
19 x 25 x 3	66261128983	66261128991	66261129000	6000 - 9000	63642556790	50
19 x 38 x 3	66261128984	66261128992	66261129001	6000 - 9000	63642556791	50

Other grits and sizes available upon request.

**SPIRAL ZSPI**

DIM BSxLxB (mm)	GRIT			RECOMMEND SPEED (RPM)	MANDREL CODE	PK QTY
	60	80	120			
10 x 25 x 3	66261129485	66261129492	66261129500	11500 - 17200	63642556790	50
10 x 38 x 3	66261129486	66261129493	66261129501	11500 - 17200	63642556791	50
10 x 50 x 3	66261129487	66261129494	66261129503	11500 - 17200	66261138811	50
13 x 25 x 3	66261129488	66261129495	66261129505	8800 - 13200	63642556790	50
13 x 38 x 3	66261129489	66261129496	66261129514	8800 - 13200	63642556791	50
19 x 38 x 3	66261129490	66261129497	66261129516	6000 - 9000	63642556791	50
19 x 50 x 3	66261129491	66261129498	66261129517	6000 - 9000	66261138811	50

Other grits and sizes available upon request.



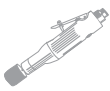

## X-TREME R422

CARTRIDGE AND SPIRAL ROLL

BETTER ++++

**X-TREME**



The BETTER choice for for tough, difficult-to-grind materials as well as soft, loading materials.

### FEATURES

- Sharp silicon carbide abrasive
- Durable resin bond system

### BENEFITS

- For high initial cut on non-ferrous and soft-loading materials such as titanium, masonry, composites, plastic and rubber
- Ideal solution for titanium and non-ferrous aircraft and engine parts grinding
- For exceptional grain retention and longer life
- For sanding & polishing channels, fillets, recesses, radii, small contours & the bottom of dead-end holes

## STRAIGHT ZPE

DIM BSxLxB (mm)	GRIT			RECOMMEND SPEED (RPM)	MANDREL CODE	PK QTY
	60	80	120			
6 x 25 x 3	66261129002	66261129012	66261129069	19000 - 28600	63642556790	50
6 x 38 x 3	66261129003	66261129014	66261129070	19000 - 28600	63642556791	50
10 x 25 x 3	66261129005	66261129015	66261129071	11500 - 17200	63642556790	50
10 x 38 x 3	66261129006	66261129016	66261129072	11500 - 17200	63642556791	50
13 x 25 x 3	66261129007	66261129017	66261129073	8800 - 13200	63642556790	50
13 x 38 x 3	66261129008	66261129018	66261129074	8800 - 13200	63642556791	50
19 x 25 x 3	66261129009	66261129019	66261129075	6000 - 9000	63642556790	50
19 x 38 x 3	66261129011	66261129020	66261129076	6000 - 9000	63642556791	50

Other grits and sizes available upon request.

## SPIRAL ZSPI

DIM BSxLxB (mm)	GRIT			RECOMMEND SPEED (RPM)	MANDREL CODE	PK QTY
	60	80	120			
10 x 25 x 3	66261129522	66261129531	66261129543	11500 - 17200	63642556790	50
10 x 38 x 3	66261129523	66261129532	66261129544	11500 - 17200	63642556791	50
10 x 50 x 3	66261129524	66261129533	66261129545	11500 - 17200	66261138811	50
13 x 25 x 3	66261129525	66261129534	66261129546	8800 - 13200	63642556790	50
13 x 38 x 3	66261129526	66261129535	66261129547	8800 - 13200	63642556791	50
19 x 38 x 3	66261129527	66261129536	66261129548	6000 - 9000	63642556791	50
19 x 50 x 3	66261129529	66261129541	66261129550	6000 - 9000	66261138811	50

Other grits and sizes available upon request.

**Dimensions Key:** DIM = Dimensions, BS = Base diameter, L = Length, B = Bore



COATED  
ABRASIVES  
& BEARTEX

BONDED  
ABRASIVES

SUPER  
ABRASIVES

DIAMOND  
TOOLS

CLEANING,  
POLISHING  
& MASKING

PERSONAL  
PROTECTION  
EQUIPMENT

TECHNICAL  
INFORMATION

## BDX R265

CARTRIDGE AND SPIRAL ROLL

GOOD +++

**BDX**



The GOOD choice for difficult-to-grind materials that require an economical option or multi-purpose applications on metals and other materials.

### FEATURES

- Premium aluminum oxide grain
- Advanced full resin bond system

### BENEFITS

- For aggressive cut and longer life
- Great for difficult-to-grind materials (aluminum, carbon steel) and applications requiring an economical option
- Runs cooler and more efficiently; ideal for grinding exotic alloys
- Ensures edge adhesion and longer life

## STRAIGHT ZPE

DIM BSxLxB (mm)	GRIT			RECOMMEND SPEED (RPM)	MANDREL CODE	PK QTY
	60	80	120			
6 x 25 x 3	66261128874	66261128894	66261128908	19000 - 28600	63642556790	50
6 x 38 x 3	66261128877	66261128899	66261128909	19000 - 28600	63642556791	50
10 x 25 x 3	66261128881	66261128900	66261128911	11500 - 17200	63642556790	50
10 x 38 x 3	66261128886	66261128901	66261128912	11500 - 17200	63642556791	50
13 x 25 x 3	66261128890	66261128903	66261128913	8800 - 13200	63642556790	50
13 x 38 x 3	66261128891	66261128904	66261128914	8800 - 13200	63642556791	50
19 x 25 x 3	66261128892	66261128905	66261128915	6000 - 9000	63642556790	50
19 x 38 x 3	66261128893	66261128906	66261128916	6000 - 9000	63642556791	50

Other grits and sizes available upon request.

## SPIRAL ZSPI

DIM BSxLxB (mm)	GRIT			RECOMMEND SPEED (RPM)	MANDREL CODE	PK QTY
	60	80	120			
10 x 25 x 3	66261129105	66261129112	66261129120	11500 - 17200	63642556790	50
10 x 38 x 3	66261129106	66261129113	66261129121	11500 - 17200	63642556791	50
10 x 50 x 3	66261129107	66261129115	66261129122	11500 - 17200	66261138811	50
13 x 25 x 3	66261129108	66261129116	66261129123	8800 - 13200	63642556790	50
13 x 38 x 3	66261129109	66261129117	66261129124	8800 - 13200	63642556791	50
19 x 38 x 3	66261129110	66261129118	66261129125	6000 - 9000	63642556791	50
19 x 50 x 3	66261129111	66261129119	66261129126	6000 - 9000	66261138811	50

Other grits and sizes available upon request.



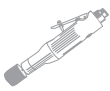

## SPECIALTIES KITS

### CARTRIDGE ROLL KITS

To help you select the correct product, the cartridge roll kit contains 122 pieces of the most popular shapes, sizes & grits

**BLAZE**  
R980

BEST  
INNOVATION

66261071558



**ALOX**  
R265

GOOD

63642557136



COATED  
ABRASIVES  
& BEARTEX

### SPECIALTIES KIT

This kit contains a small range of our Speedlok and specialties products

BEST  
INNOVATION

66254476957\*



\* Made-to-order

BONDED  
ABRASIVES

### STEEL MANDREL FOR CARTRIDGE ROLLS

DESCRIPTION	DIM DIAxL (mm)	SHAFT DIAMETER (mm)	PK QTY	ART. NO.
Steel mandrel for cartridge rolls with a 6mm shaft 	3x13	6mm	1	63642587120
	3x19	6mm	1	63642556790
	3x25	6mm	1	63642556791
	3x38	6mm	1	66261138811

SUPER  
ABRASIVES

DIAMOND  
TOOLS

**Dimensions Key:** DIM = Dimensions, BS = Base diameter, L = Length, B = Bore, DIA = Pilot diameter, L = Pilot length

CLEANING,  
POLISHING  
& MASKING

PERSONAL  
PROTECTION  
EQUIPMENT

TECHNICAL  
INFORMATION



# SPIRABANDS & CONES

Best product for high stock removal and aggression, exceptional tool life even under the most demanding operating conditions. Good choice for blending and polishing curved, contoured and hard-to-reach areas, removing parting lines, imperfections and burrs on all surfaces. The spiral construction avoids shadow marks and provides smooth, chatter-free cutting action. Easy to mount and remove from cylindrical rubber mandrel by turning slightly to the right.

Spirabands & cones achieve their best performance at a recommended speed of 20-30m/s.

Optimizing stock removal, surface finish, thermal load of the workpiece and tool wear.

## APPLICATIONS & MARKETS

- Inside surfaces, edges, contours and corners, dressing fillet weld seams
- Post-processing and repair work on metal structures
- Blending and polishing contours in the construction of equipment and vessels



COATED  
ABRASIVES  
& BEARTEX

BONDED  
ABRASIVES

SUPER  
ABRASIVES

DIAMOND  
TOOLS

CLEANING,  
POLISHING  
& MASKING

PERSONAL  
PROTECTION  
EQUIPMENT

TECHNICAL  
INFORMATION

BEST **+++++**

## BLAZE

SPIRABANDS & CONES

**BLAZE**



The next generation of specialties for metal working applications, with ceramic grain, grinding aid and cotton cloth backing. Cut cooler and last longer on stainless steel, cobalt, inconel, titanium and other hard-to-grind materials.

The maximum performance for lowest overall grinding cost on your most difficult-to-grind materials.

### FEATURES

- Premium Ceramic Alumina abrasive
- Grinding aid
- Strong X-weight cotton backing

### BENEFITS

- Provides longer life vs any other spiraband on Stainless, titanium and super alloys
- Reduces heat, loading and glazing
- Heavy duty application with maximum stock removal

## ABRASIVE SPIRABANDS

DIM DIAxW (mm)	GRIT			RECOMMEND SPEED (RPM)	MANDREL CODE	PK QTY
	36	60	80			
15 x 30	66261137086	66623331569	66623331571	25000 - 31500	07660705182	100
22 x 20	66254402665	66261192992	66623330997	17500 - 21000	63642562578	100
25 x 25	66261137090	66623331005	66623331007	15300 - 19000	07660705183	100
30 x 30	66261137092	66254493572	63642504970	12700 - 15800	07660707918	100
45 x 30	66254402667	66261031600	66623331020	9250 - 10500	07660705196	100
60 x 30	66261137185	66261137186	66261137187	6500 - 7900	07660717631	100

Other grits and sizes available upon request.

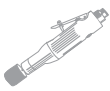

## ABRASIVE CONES

DIM DBxDTxH (mm)	GRIT			RECOMMEND SPEED (RPM)	MANDREL CODE	PK QTY
	40	60	80			
20 x 14 x 63	66261137657	66261137658	66261137659	19000 - 22000	07660740439	100
29 x 22 x 30	66261137662	66261137671	77696086973	13000 - 15800	77696089374	100
36 x 22 x 60	66261137664	66261137667	66261137669	10000 - 12500	07660740441	100

Other grits and sizes available upon request.

**Dimensions Key:** DIM = Dimensions, DIA = Diameter, W = Width,  
DB = Base diameter, DT = Top diameter, H = Height

COATED  
ABRASIVES  
& BEARTEX

BONDED  
ABRASIVES

SUPER  
ABRASIVES

DIAMOND  
TOOLS

CLEANING,  
POLISHING  
& MASKING

PERSONAL  
PROTECTION  
EQUIPMENT

TECHNICAL  
INFORMATION

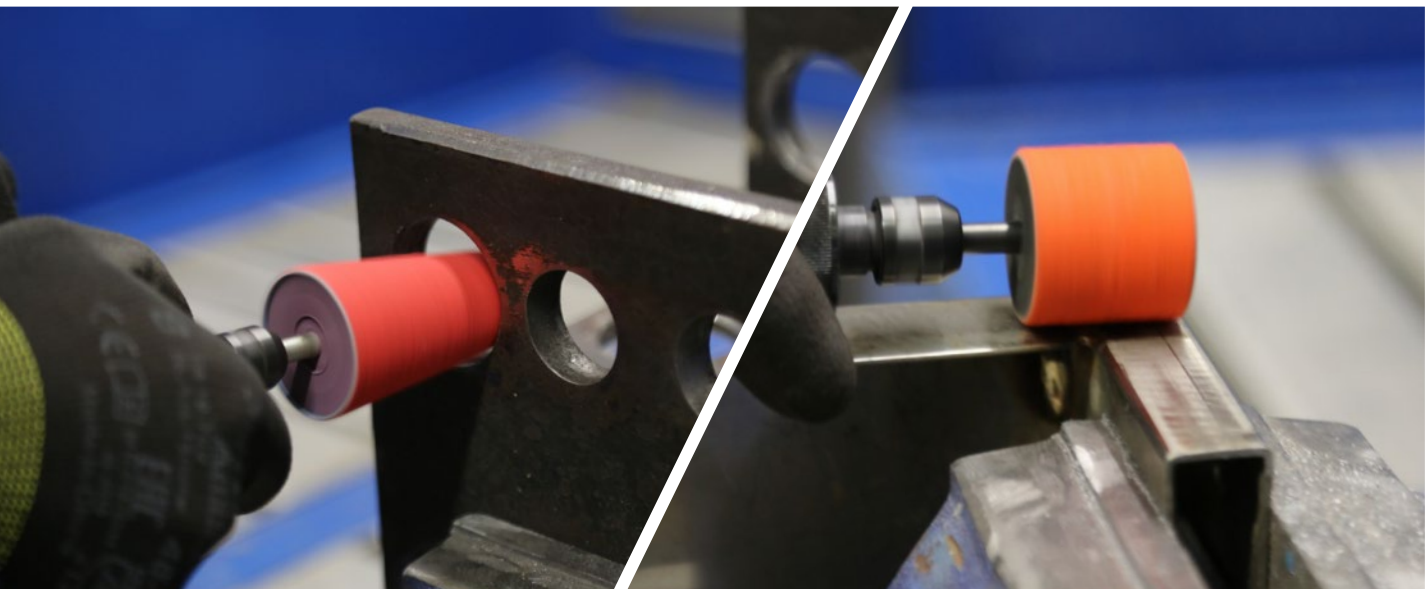

## X-TREME R822 SPIRABANDS & CONES

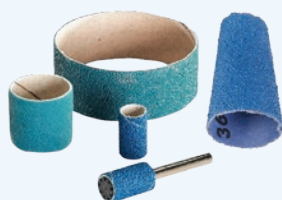
**BETTER ++++**
**X-TREME**

The BETTER choice for carbon steel and welds.

### FEATURES

- Premium Zirconia alumina abrasive
- Semi-open coat
- Selection of sizes & grades

### BENEFITS

- Delivers aggressive cut rate and longer life on carbon steel and welds
- Prevents loading on aluminum
- Ideal for use on irregular shaped components such as curves, or recesses

## ABRASIVE SPIRABANDS

DIM DIAxW (mm)	GRIT				RECOMMEND SPEED (RPM)	MANDREL CODE	PK QTY
	36	50	60	80			
13 x 25	66261176616	63642528507	66261032722	63642528508	29400 - 36500	07660705185	100
15 x 30	66261034127	63642528509	66623386740	63642528496	25000 - 31500	07660705182	100
22 x 20	63642539865	63642528497	63642539866	63642539867	17500 - 21000	63642562578	100
25 x 25	63642528510	63642528511	66623316384	63642528512	15300 - 19000	07660705183	100
30 x 30	63642566870	63642535053	63642545925	63642545926	12700 - 15800	07660707918	100
38 x 25	66261180965	66261180966	66261137836	66261180967	10000 - 12500	07660717568	100
45 x 30	63642528498	63642528514	63642545928	63642528515	9250 - 10500	07660705196	100
51 x 25	63642528516	66261180974	66261137837	63642528518	7500 - 9300	07660705184	100
60 x 30	63642536541	63642539765	63642539874	63642539766	6500 - 7900	07660717631	100

Other grits and sizes available upon request.

## ABRASIVE CONES

DIM DBxDTxH (mm)	GRIT				RECOMMEND SPEED (RPM)	MANDREL CODE	PK QTY
	36	50	80	120			
20 x 14 x 63	66261176761	66261176657	66261176656	66261176540	19000 - 22000	07660740439	100
29 x 22 x 30	66261137713	63642513692	77696086972	77696081341	13000 - 15800	77696089374	100
36 x 22 x 60	63642520987	63642536572	63642545922	66261176703	10000 - 12500	07660740441	100

Other grits and sizes available upon request.

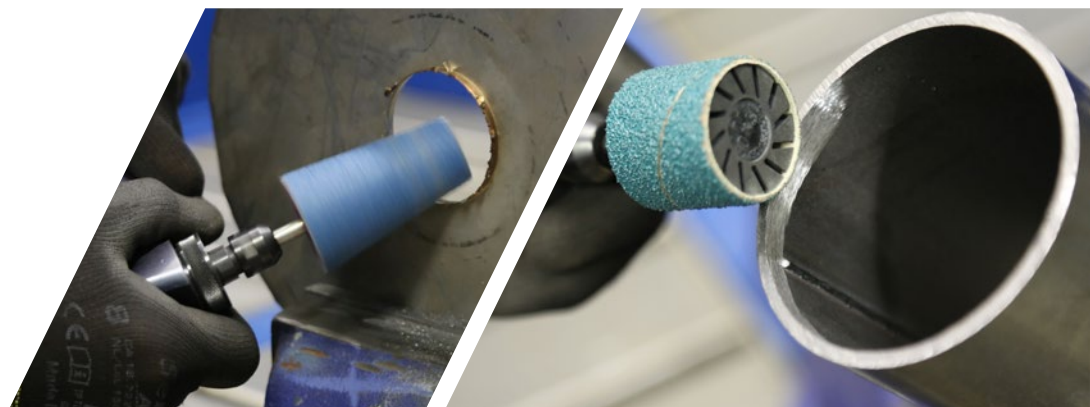

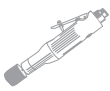

**BDX R265**  
SPIRABANDS & CONES

**GOOD +++**

**BDX**



The GOOD choice for light-duty applications on difficult-to-grind materials and multi-purpose applications on metals and other materials.

**FEATURES**

- Premium aluminum oxide grain
- Selection of sizes & grades

**BENEFITS**

- For aggressive cut and longer life
- Great for difficult-to-grind materials like aluminum and applications requiring an economical option (carbon steel)
- Ideal for use on irregular shaped components such as curves, or recesses

**ABRASIVE SPIRABANDS**

DIM DIAxW (mm)	GRIT				RECOMMEND SPEED (RPM)	MANDREL CODE	PK QTY
	40	60	80	120			
10 x 20		66261136693	66261136728	66261136749	38200 - 47500	07660717573	100
13 x 25		66261136694	66261136729	66261136750	29400 - 36500	07660705185	100
15 x 30	66261136518	66261136695	66261136730	66261136752	25000 - 31500	07660705182	100
22 x 20	66261136521	66261136697	66261136731	66261136753	17500 - 21000	63642562578	100
25 x 25	66261136668	66261136699	66261136732	66261136757	15300 - 19000	07660705183	100
30 x 30	66261136669	66261136702	66261136733	66261136758	12700 - 15800	07660707918	100
38 x 25	66261136670	66261136703	66261136745	66261136760	10000 - 12500	07660717568	100
45 x 30	66261136672	77696087388	77696087387	66261136761	9250 - 10500	07660705196	100
51 x 25	66261136673	66261136704	66261136746	66261136762	7500 - 9300	07660705184	100
60 x 30	66261136674	66261136705	66261136747	66261136763	6500 - 7900	07660717631	100
75 x 30	66261136675	66261136707	66261136748	66261136764	5100 - 6300	07660739762*	100

Other grits and sizes available upon request.

\* Mandrel with a 8mm shaft

**ABRASIVE CONES**

DIM DBxDTxH (mm)	GRIT				RECOMMEND SPEED (RPM)	MANDREL CODE	PK QTY
	40	60	80	120			
20 x 14 x 63	66261137724	66261137688	66261137689	66261137691	19000 - 22000	07660740439	100
29 x 22 x 30	66261137717	66261137719	66261137720	66261137721	13000 - 15800	77696089374	100
36 x 22 x 60	66261137693	66261137696	66261137697	66261137698	10000 - 12500	07660740441	100

Other grits and sizes available upon request.

**Dimensions Key:** DIM = Dimensions, DIA = Diameter, W = Width, DB = Base diameter, DT = Top diameter, H = Height



COATED  
ABRASIVES  
& BEARTEX

BONDED  
ABRASIVES

SUPER  
ABRASIVES

DIAMOND  
TOOLS

CLEANING,  
POLISHING  
& MASKING

PERSONAL  
PROTECTION  
EQUIPMENT

TECHNICAL  
INFORMATION



# MANDREL FOR SPIRABANDS & CONES

## RUBBER MANDREL FOR SPIRABANDS

DIM DIAxW(mm)	SHAFT DIAMETER (mm)	MAX RPM	MIN RPM	PK QTY	
10x20	6mm	47500	33250	1	07660717573
13x25	6mm	36500	25500	1	07660705185
15x30	6mm	31500	22000	1	07660705182
22x20	6mm	21000	14700	1	63642562578
25x25	6mm	19000	13000	1	07660705183
30x30	6mm	15800	11000	1	07660707918
38x25	6mm	12500	8700	1	07660717568
45x30	6mm	10500	9000	1	07660705196
51x25	6mm	9300	7400	1	07660705184
60x30	6mm	7900	6500	1	07660717631
75x30	8mm	6300	4500	1	07660739762



## RUBBER MANDREL FOR CONES

DIM DBxDTxH (mm)	SHAFT DIAMETER (mm)	MAX RPM	MIN RPM	PK QTY	
20x14x63	6mm	22000	15000	1	07660740439
29x22x30	6mm	15800	10500	1	77696089374
36x22x63	6mm	12500	8750	1	07660740441

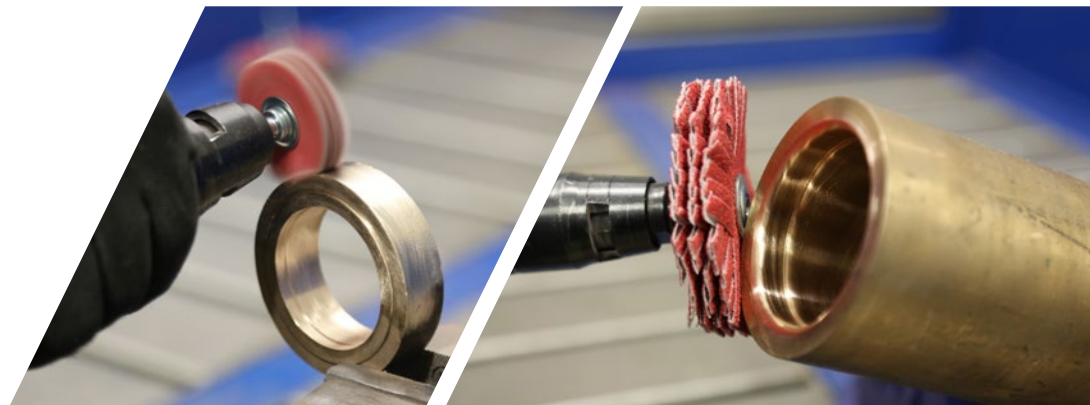
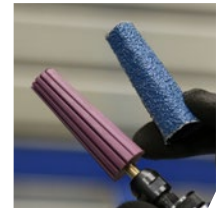

COATED  
ABRASIVES  
& BEARTEX

BONDED  
ABRASIVES

SUPER  
ABRASIVES

DIAMOND  
TOOLS

CLEANING,  
POLISHING  
& MASKING

PERSONAL  
PROTECTION  
EQUIPMENT

TECHNICAL  
INFORMATION

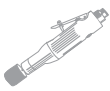

# SANDING STARS

Ideal for deburring & finishing difficult to access metal applications, irregular shaped components, holes, radi and grooves as small as 35mm as well as removing sharp edges which may cause manual handling problems on irregular or awkward sized components.

The perfect tool for applications requiring a perfect 360° finish, ideal for irregular surfaces due to high flexibility and conformability. Sanding stars are a multi-layered abrasive tool that are rived together on a 6mm shaft.

Sanding stars achieve their best performance at a recommended speed of 15-25m/s. Optimizing stock removal, surface finish, thermal load of the workpiece and tool wear.



COATED  
ABRASIVES  
& BEARTEX

BONDED  
ABRASIVES

SUPER  
ABRASIVES

DIAMOND  
TOOLS

CLEANING,  
POLISHING  
& MASKING

PERSONAL  
PROTECTION  
EQUIPMENT

TECHNICAL  
INFORMATION

BEST +++++

## BLAZE R946 SANDING STARS

**BLAZE**



The next generation of specialties for metal working applications with ceramic grain, grinding aid and J PolyCotton backing. Cut cooler and last longer on stainless steel, cobalt, inconel, titanium and other hard-to-grind materials: maximum performance for lowest overall grinding cost on your most difficult-to-grind materials.

### FEATURES

- Premium Ceramic Alumina abrasive
- Super flexible cloth

### BENEFITS

- Provides longer life vs any sanding star on Stainless, titanium and super alloys
- Reduced heat, loading and glazing on stainless, titanium and super alloys
- Conformable to irregular shaped components and contours
- Heavy duty application

DIA (mm)	GRIT		RECOMMEND SPEED (RPM)	NUMBER OF PLYES	PK QTY
	P60	P120			
40	66261131904	66261132447	7200 - 12000	12	10
60	66261132442	66261132449	4800 - 8000	12	10
80	66261132444	66261132451	3600 - 6000	12	10
100	66261132445	66261132452	2900 - 4800	12	10

Other grits and sizes available upon request.

**Dimensions Key:** DIM = Dimensions, DIA = Diameter, W = Width, DB = Base diameter, DT = Top diameter, H = Height

## X-TREME R426

### SANDING STARS

**BETTER ++++**
**X-TREME**

The BETTER choice for brass, non-ferrous materials, stone, glass and plastic.

#### FEATURES

- Sharp silicon carbide abrasive
- Super flexible cloth

#### BENEFITS

- For high initial cut and penetration for stainless steel, brass, nonferrous materials and wood
- To irregular shaped components and contours
- Medium-duty application

DIA (mm)	GRIT		RECOMMEND SPEED (RPM)	NUMBER OF PLYES	PK QTY
	P80	P120			
40	66261132490	66261132497	7200 - 12000	12	10
60	66261132492	66261132499	4800 - 8000	12	10
80	66261132494	66261132564	3600 - 6000	12	10
100	66261132495	66261132565	2900 - 4800	12	10

Other grits and sizes available upon request.

## BDX R309

### SANDING STARS

**GOOD +++**
**BDX**

The GOOD choice for light-duty applications on difficult-to-grind materials and soft materials that require an economical option e.g. aluminum, carbon steel and wood.

#### FEATURES

- Premium aluminum oxide grain
- Super flexible cloth

#### BENEFITS

- For aggressive cut and longer life
- Great for difficult-to-grind materials (aluminum, carbon steel) and applications requiring an economical option
- Conformable to irregular shaped components and contours

DIA (mm)	GRIT		RECOMMEND SPEED (RPM)	NUMBER OF PLYES	PK QTY
	P60	P120			
40	66261132593	66261132649	7200 - 12000	12	10
60	66261132603	66261132651	4800 - 8000	12	10
80	66261132605	66261133148	3600 - 6000	12	10
100	66261132606	66261133150	2900 - 4800	12	10

Other grits and sizes available upon request.



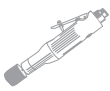

# STRIPPING & CLEANING

## BLAZE RAPID STRIP WHEELS

BEST +++++



### FEATURES

- Heavy coating of Norton SG Blaze ceramic alumina long-lasting grain and advanced resin bond
- Extremely versatile; use one disc for multiple operations
- Open structure

### BENEFITS

- Last 2x longer than competitors
- Will not shed on rust-encrusted pieces, or load on soft metals
- Lighter pressure will finish similar to a medium grit; additional pressure will remove material (strip and clean)
- Less downtime, and less production waste/landfill scrap

DIM DIAxWxB(mm)	CAP CODE	PK QTY	MAX RPM	ART. NO.
100x13x12	R9101	25	8000	66623304856
150x13x12	R9101	15	8000	66261099378
200x13x12	R9102	5	4500	66623393517*

\* Made-to-order

## BLAZE RAPID STRIP WHEELS SPINDLE MOUNTED

DIM DIAxTxS(mm)	CAP CODE	PK QTY	MAX RPM	ART. NO.
100x13x6	R9101	5	8000	66623378059
150x13x8	R9101	10	5500	66623334482

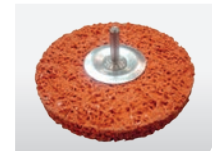

**Dimensions Key:** DIM = Dimensions, DIA = Diameter, W = Width, B = Bore, T = Thickness, S = Spindle

COATED ABRASIVES & BEARTEX

BONDED ABRASIVES

SUPER ABRASIVES

DIAMOND TOOLS

CLEANING, POLISHING & MASKING

PERSONAL PROTECTION EQUIPMENT

TECHNICAL INFORMATION



## RAPID STRIP

## WHEELS

GOOD +++

**Rapid**  
STRIP

## FEATURES

- Open web construction
- Conformable
- Thick, strong, synthetic fibres & extra coarse grit
- Used with portable tools

## BENEFITS

- Fast cutting action with very little loading
- Easy cleaning of uneven surfaces
- Quick cleaning & conditioning of surfaces
- Easy & safe to use especially in difficult to reach areas

DIM DIAxWxB(mm)	CAP CODE	PK QTY	RPM	ART. NO.
--------------------	----------	-----------	-----	----------

## STANDARD

100x13x12	R4101	25	8000	63642585700
150x13x12	R4101	15	5500	63642585703
200x13x12	R4101	5	4500	63642585704

## SPINDLE MOUNTED - STANDARD (1 WHEEL)

75x13x6	R4101	10	10000	63642557741
100x13x6	R4101	10	8000	63642557742
150x13x8	R4101	10	6000	63642557743

## SPINDLE MOUNTED - LARGE AREA (2 WHEELS GANGED)

75x25x6	R4101	5	10000	63642557744
100x25x6	R4101	5	8000	63642557745
150x25x8	R4101	5	6000	63642557746

## MANDRELS STANDARD WHEELS

DISCS DIAxWxB(mm)	SPINDLE DIA(mm)	PK QTY	
<150x13x12	6	1	07660707022
<200x13x12	8	1	07660707023



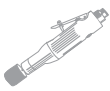

# RAPID BLEND UNITISED WHEELS

Unitised wheels are made from compressed and bonded layers of non-woven abrasive. Applications include deburring, cleaning composites, and sharp edge removal.

Unitised wheels produce excellent finishes on nearly all surfaces, although are ideally suited for use on harder materials such as titanium or stainless steel.

## APPLICATIONS & MARKETS

- Surface preparation, cleaning & finishing
- Turbine blades & aerospace maintenance
- Medical instruments
- Cleaning weld lines & moulds
- Tooling industry



## VORTEX RAPID BLEND UNITISED WHEELS CLOSED STRUCTURE

BETTER ++++



### FEATURES

- High-performance engineered grain and improved resin bond system
- Thick nylon web
- Porous
- New curing process and bond technology
- Excellent form holding, preformable
- Up to 2x the number of pieces finished

### BENEFITS

- Aggressive, fast stock removal, reduced cycle times, increased part quality
- 2x longer life and faster finishing – with minimal shedding
- Cool cutting and improved cut rate
- Consistent performance from first contact to stub size, improved part quality
- Will not break down under heavy deburring conditions
- Can be used on a variety of shapes and contours
- Less downtime for changes; maximum productivity

DIM DIAxWxB(mm)	CAP CODE	GRADE	PK QTY	RPM	ART. NO.
50x6x6	U2305	VOR-7AM	60	22100	66261080270
75x3x6	U2305	VOR-5AM	40	18000	66261093448
	U2305	VOR-7AM	40	18000	66261191445
75x6x6	U2305	VOR-3AM	40	18000	66254428454
	U2305	VOR-5AM	40	18000	66254414832
	U2305	VOR-7AM	40	18000	66261199696
75x13x6	U2305	VOR-7AM	20	18000	66261080267
125x6x22	U2305	VOR-5AM	20	9000	66254488602
150x6x25	U2305	VOR-5AM	8	7500	66254414167
	U2305	VOR-7AM	8	7500	66254407225

**Dimensions Key:** DIM = Dimensions, DIA = Diameter, W = Width, B = Bore

COATED  
ABRASIVES  
& BEARTEX

BONDED  
ABRASIVES

SUPER  
ABRASIVES

DIAMOND  
TOOLS

CLEANING,  
POLISHING  
& MASKING

PERSONAL  
PROTECTION  
EQUIPMENT

TECHNICAL  
INFORMATION

## VORTEX WHEELS SPINDLE MOUNTED

DIM DxTxS(mm)	CAP CODE	GRADE	PK QTY	RPM	
150x13x8	U2305	3AM	10	8000	66623375067

## RAPID BLEND NEX UNITISED WHEELS

GOOD +++

**Rapid**  
BLEND



### FEATURES

- Easily preformed, holds shape well
- Uniform construction
- Smear resistant formula
- New light density formulation in 2SF and 3SF
- Non-metallic, small sizes available

### BENEFITS

- Usable on a wide variety of shapes/contours
- Less wheel dressing, more snag resistant
- No contamination of workpiece
- Long life. Maintains part tolerance, prevents cutting or gouging

DIM DIAxWxB(mm)	CAP CODE	GRADE	PK QTY	RPM	ART. NO.
50x3x6	U2301	NEX-8AM	20	22100	63642585828*
50x6x6	U2301	NEX-2AM	20	18000	63642585754
	U4401	NEX-2SF	20	18000	63642585756
	U2401	NEX-4AF	20	22100	63642585755
	U2401	NEX-6AF	20	22100	63642585757
	U2201	NEX-8AC	20	22100	63642585761
75x3x6	U2301	NEX-8AM	20	22100	63642585758
	U2301	NEX-8AM	20	18100	63642585831
75x6x6	U2301	NEX-2AM	10	12100	63642585763*
	U4401	NEX-2SF	10	12100	63642585768
	U4401	NEX-3SF	10	12100	63642571113
	U2401	NEX-4AF	10	18100	63642585766
	U2401	NEX-6AF	10	18100	63642585771
	U2301	NEX-6AM	10	18100	66261081929*
	U2201	NEX-8AC	10	18100	63642585776
125x6x22	U2301	NEX-8AM	10	18100	63642585774
	U4401	NEX-2SF	20	6000	66254488603
150x6x13	U4401	NEX-3SF	20	6000	66254489419
	U2301	NEX-2AM	10	4500	66261019412
	U4401	NEX-2SF	10	5000	66261019416
	U4401	NEX-3SF	8	5000	66261016691
150x6x25	U2301	NEX-6AM	10	7500	66261019414
	U4401	NEX-2SF	8	7500	66261017050
	U4401	NEX-3SF	8	7500	66254489421

\* Made-to-order

COATED  
ABRASIVES  
& BEARTEX

BONDED  
ABRASIVES

SUPER  
ABRASIVES

DIAMOND  
TOOLS

CLEANING,  
POLISHING  
& MASKING

PERSONAL  
PROTECTION  
EQUIPMENT

TECHNICAL  
INFORMATION

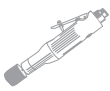

## RAPID BLEND NEX UNITISED WHEELS

DIM DxWxB(mm)	CAP CODE	GRADE	PK QTY	RPM	ART. NO.
150x13x13	U2301	NEX-2AM	5	4500	63642585818
	U4401	NEX-2SF	5	5000	63642585812
	U4401	NEX-3SF	4	5000	66261015826
	U2401	NEX-4AF	5	7500	63642585815
	U2301	NEX-8AM	5	7500	63642585824
150x25x13	U2301	NEX-2AM	5	4500	69957350267
	U4401	NEX-2SF	5	5000	69957350272
	U2401	NEX-4AF	5	7500	69957350269
150x25x25	U2301	NEX-2AM	5	4500	63642585789*
	U4401	NEX-2SF	5	5000	63642585795
	U2401	NEX-4AF	5	7500	63642585792
	U2301	NEX-6AM	8	7500	66261015989
200x25x25	U2301	NEX-2AM	5	3500	63642585796
	U4401	NEX-2SF	5	4000	63642585797

\* Made-to-order

Other sizes, grades & densities available upon request. Metal bushings are also available to reduce the bore size, please refer to the accessories section at the back of this catalogue for more information.

COATED  
ABRASIVES  
& BEARTEX

BONDED  
ABRASIVES

SUPER  
ABRASIVES

DIAMOND  
TOOLS

CLEANING,  
POLISHING  
& MASKING

PERSONAL  
PROTECTION  
EQUIPMENT

TECHNICAL  
INFORMATION



## UNITISED SMALL WHEELS / BOBS

DIM DxTxB(mm)	CAP CODE	GRADE	PK QTY	ART. NO.
25x25x5	U4401	NEX 2SF	50	66261014883
25x25x5	U2301	NEX 6AM	50	66261014908
Use with Threaded Mandrel			1	66261077832

**Dimensions Key:** DIM = Dimensions, DIA/D = Diameter, W = Width, B = Bore, T = Thickness, S = Spindle



## PRODUCT SELECTION

APPLICATION AREA	SPECIFIC APPLICATION	SPECIFICATION
UNITISED WHEELS		
Cleaning: oxidation removal, coatings, contaminations	<ul style="list-style-type: none"> <li>Welding preparation</li> <li>Removal of weld blueing, scale</li> <li>Removal, gasket removal</li> <li>Removing excessive bonding agents after curing, cleaning steel castings</li> </ul>	<ul style="list-style-type: none"> <li>NEX 4AFINE</li> <li>NEX 6AFINE</li> </ul>
Deburring: surface, edge, ID_OD & thread deburring	<ul style="list-style-type: none"> <li>Deburring flashings</li> <li>Threaded parts</li> <li>Stamped parts, turbine blades, machined out parts</li> <li>Deburr aluminium extrusions,</li> <li>Deburring of pipes in the oil &amp; gas industry</li> </ul>	<ul style="list-style-type: none"> <li>NEX 2SFINE</li> <li>NEX 4AFINE</li> <li>Vortex 7AM</li> </ul>
Deburring: OD & thread deburring	<ul style="list-style-type: none"> <li>Deburring of pipe threads in oil &amp; gas industry</li> </ul>	<ul style="list-style-type: none"> <li>Vortex 7AM</li> </ul>
Blending: removal of parting lines, grindline conditioning	<ul style="list-style-type: none"> <li>Parting line removal, blending surface defects &amp; forge marks</li> </ul>	<ul style="list-style-type: none"> <li>NEX 8MED</li> <li>NEX 8ACOURSE</li> </ul>
Finishing: final finishing, satin finishing	<ul style="list-style-type: none"> <li>Turbine blade edge radius, medical implants (stainless steel &amp; alloys)</li> <li>Figurines, jewellery, finishing saw blades</li> </ul>	<ul style="list-style-type: none"> <li>NEX 6A FINE</li> <li>NEX 8AMED</li> </ul>
Polishing: polishing surface defects, preparation before buffing	<ul style="list-style-type: none"> <li>Polishing precision metal pieces, welds etc.</li> </ul>	<ul style="list-style-type: none"> <li>NEX 2SFINE</li> <li>NEX 8AFINE</li> </ul>

## UNITISED WHEEL NAMING SCHEME

NEX - 8AC	Product Line	Density	Abrasive Type	Grit Size
Name of product line: NEX	NEX	2      Soft	<b>A = Aluminium Oxide</b>	F = Fine
Naming scheme: similar to convolute wheels		3      ↑	S = Silicon Carbide	M = Medium
		4      ↑		<b>C = Coarse</b>
		5      ↑		XC = Extra Coarse
		6      ↑		
		7      ↑		
		8      ↓		
		9      Hard		

### APPLICATIONS

- For all heavy deburring and finishing applications
- Remove grind lines, punched hole burrs and pits or scratches
- Deburring Stainless Steel sinks, tanks and other food equipment
- Thread deburring operations
- Good alternative to spindle-mounted flap wheels and cotton-laminated wheels, which often generate unpleasant odours when grinding.



### SPEC CHECK

- Unitized wheels can be run in either direction.

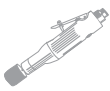

# ACCESSORIES FOR DIE GRINDER

## MANDRELS

Accessory	For BearTex Product type	DIM LxSxW (mm)	For Wheel/disc dia (mm)	Max usable wheel/disc width (mm)	For wheels/discs bore hole dia (mm)	PK QTY	ART. NO.
Mandrels with Washers	RapidStrip/ Plain Discs	55x6 x40	up to 150	13	10 to 12	1	07660707022
Mandrels with Washers	RapidStrip/ Plain Discs/ large dia Unitised Wheels >150mm	55x8x38	up to 200	13	10 to 13	1	07660707023
Mandrels	Unitised Wheels	60x6	up to 75	6	6 & 10	1	63642586234
Mandrels	Unitised Wheels	75x6	up to 75	6 to 12	6 & 10	1	63642586236
Mandrels	Unitised Wheels	85x6	up to 150	12 to 25	6	1	63642586239
Threaded Mandrel	Unitised Wheels/Bobs	25x6	25	25	5	1	66261077832



COATED ABRASIVES & BEARTEX

BONDED ABRASIVES

SUPER ABRASIVES

DIAMOND TOOLS

CLEANING, POLISHING & MASKING

PERSONAL PROTECTION EQUIPMENT

TECHNICAL INFORMATION

**Dimensions Key:** DIM = Dimensions, L = Length, S = Spindle, W = Width



# 171-196 DISC SANDERS

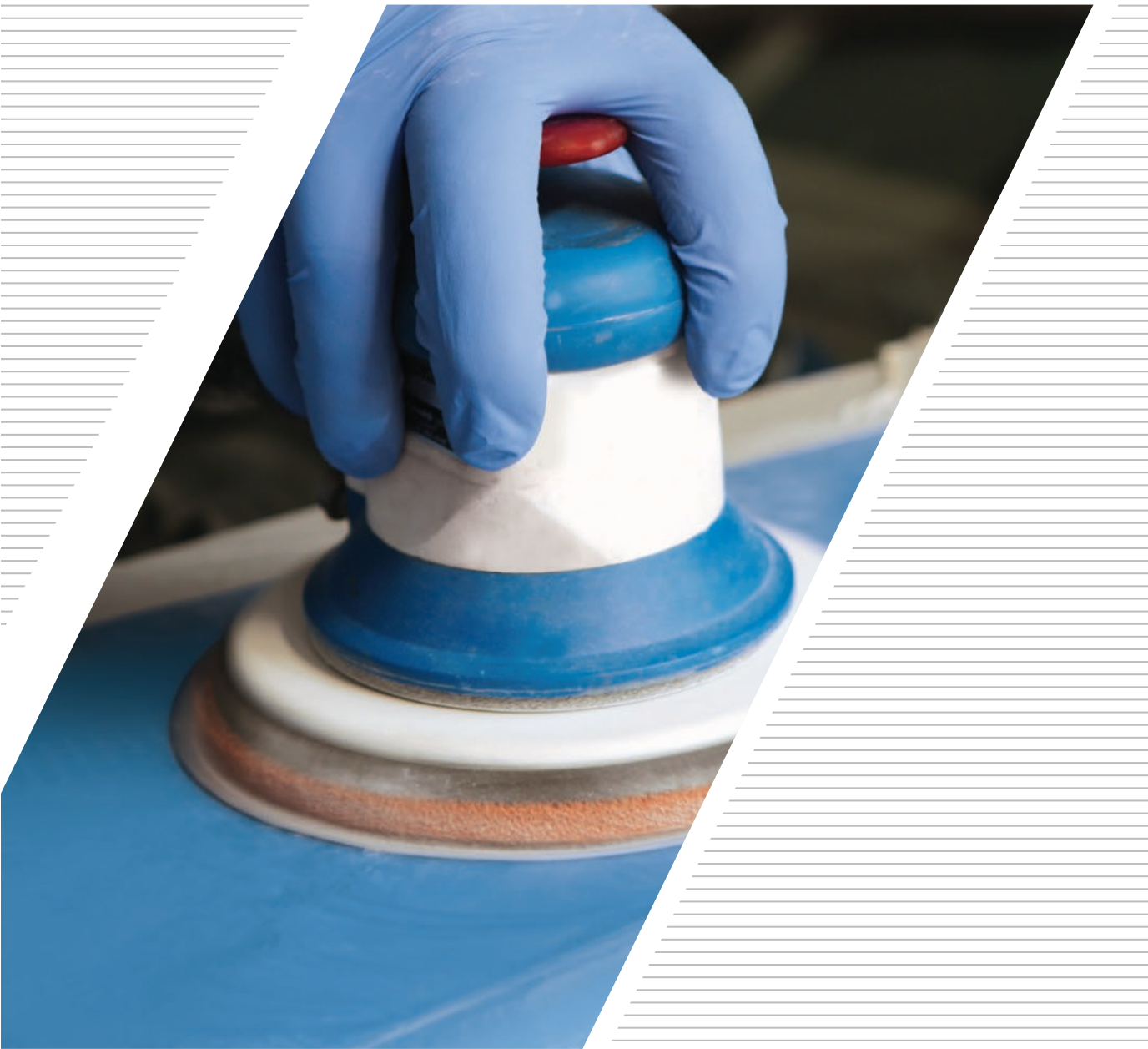

COATED  
ABRASIVES  
& BEARTEX

BONDED  
ABRASIVES

SUPER  
ABRASIVES

DIAMOND  
TOOLS

CLEANING,  
POLISHING  
& MASKING

PERSONAL  
PROTECTION  
EQUIPMENT

TECHNICAL  
INFORMATION

172 Introduction  
174 Multi-Air Discs

181 Self-Grip<sup>†</sup> &  
Soft-Touch Discs

191 Backup Pads  
194 Self-Adhesive Discs

<sup>†</sup> To help better describe the abrasive fixing system we have changed the name from 'NorGrip' to 'Self-Grip'.



# INTRODUCTION TO THE MULTI-AIR PROCESS

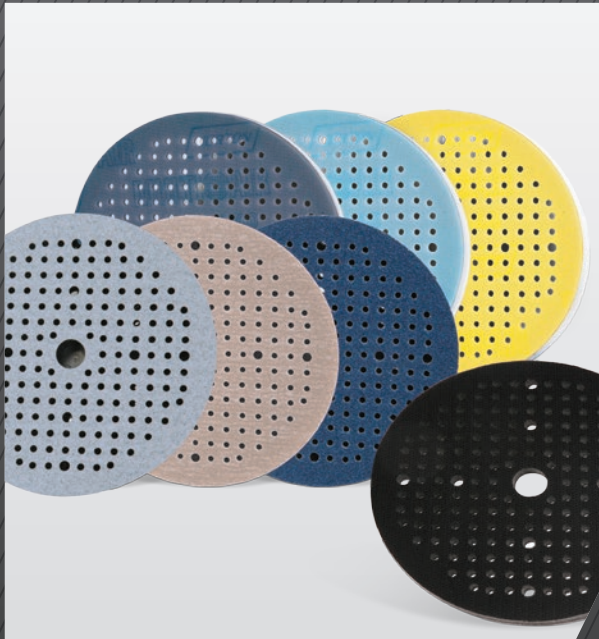

Norton Multi-Air Process combines the excellence of a premium Norton Multi-Air abrasive disc with an innovative dust-extraction Multi-Air back-up pad.

This revolutionary Multi-Air Process gives operators the optimal sanding solution to optimize performance, increase productivity and eliminate dust.

The innovative pad design draws dust into a collection chamber allowing optimal airflow and powerful dust extraction.

Multi-Air addresses multiple markets including those sanding primed and painted parts in the automotive industry, composites, marine gel coat, furniture, non-ferrous metals and many more.

**MULTI-AIR IS PROVEN TECHNOLOGY  
ALREADY ADOPTED BY THOUSANDS  
OF USERS AROUND THE WORLD.**

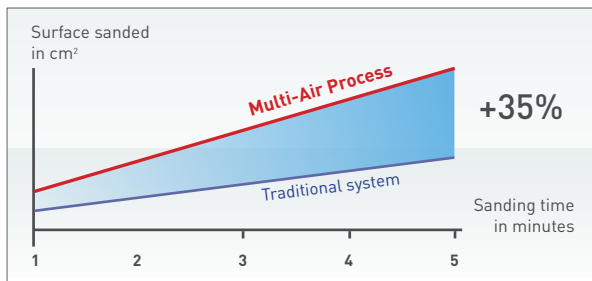

35% more surface area sanded than conventional system.

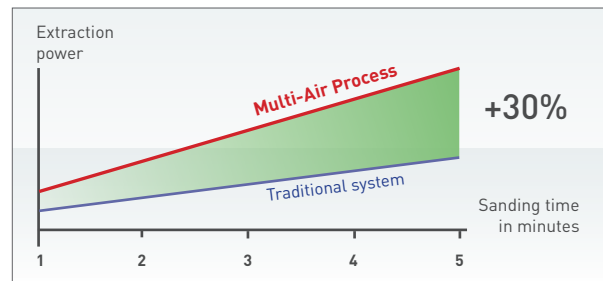

30% better dust extraction capacity than conventional system.

## FEATURES

- Insuperable design for maximum dust extraction
- Cutting surface of disc remains clean
- Premium abrasive grain
- Unique Soft-Touch discs

## BENEFITS

- Clogging is virtually eliminated
- Cleaner working environment
- Less dust and contamination
- Consistent cut throughout disc life
- Substantially longer life and faster cut than conventional abrasives



## NORTON MULTI-AIR PROCESS

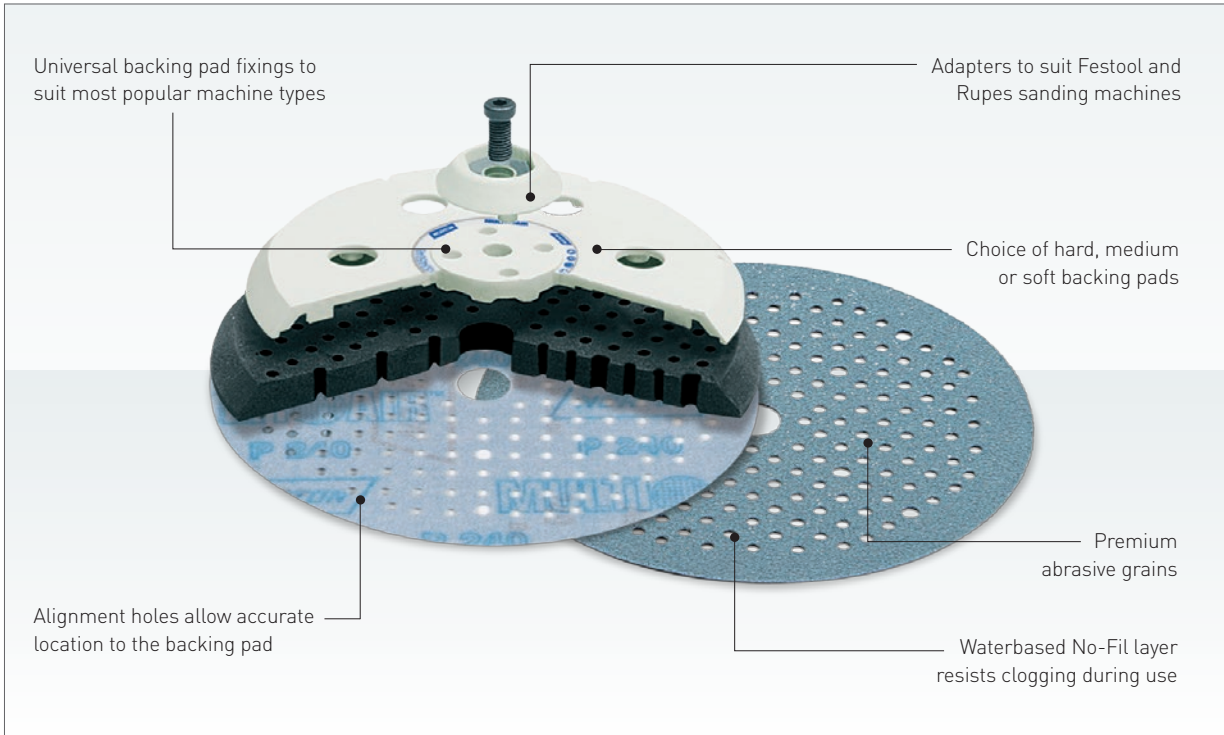

## DUST EXTRACTION SYSTEM

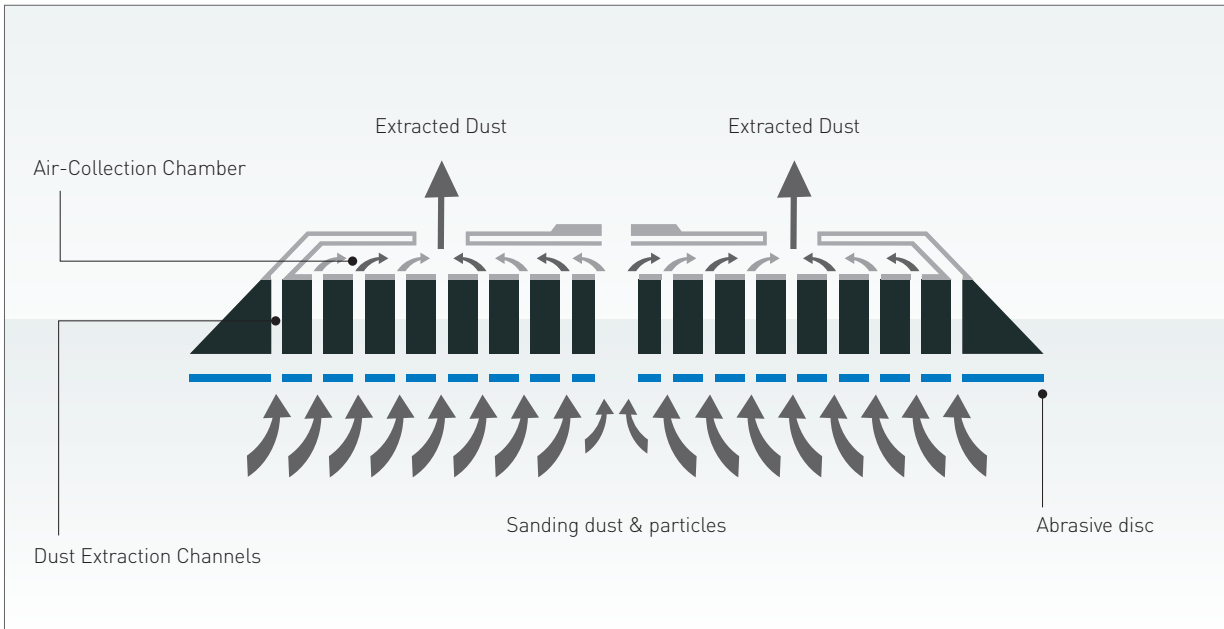

### EXTRACTION HOLES

- 181 holes maximize dust removal for 150mm
- 125 holes maximize dust removal for 125mm

The overall abrasive area is similar to that of conventional discs with traditional 7, 9 or 15 holes dust extraction.

COATED  
ABRASIVES  
& BEARTEX

BONDED  
ABRASIVES

SUPER  
ABRASIVES

DIAMOND  
TOOLS

CLEANING,  
POLISHING  
& MASKING

PERSONAL  
PROTECTION  
EQUIPMENT

TECHNICAL  
INFORMATION

# MULTI-AIR DISCS

Norton Multi-Air Process combines the excellence of a premium Norton Multi-Air abrasive disc with an innovative dust-extraction Multi-Air back-up pad.

This revolutionary Multi-Air Process gives operators the optimal sanding solution to optimise performance, increase productivity and eliminate dust.

## APPLICATIONS & MARKETS

- Automotive
- Furniture
- Paint
- Composites
- Primer
- Marine gel coat
- Non-ferrous metals
- Aerospace



COATED ABRASIVES & BEARTEX

BONDED ABRASIVES

SUPER ABRASIVES

DIAMOND TOOLS

CLEANING, POLISHING & MASKING

PERSONAL PROTECTION EQUIPMENT

TECHNICAL INFORMATION

## MULTI-AIR PLUS A975

BEST +++++

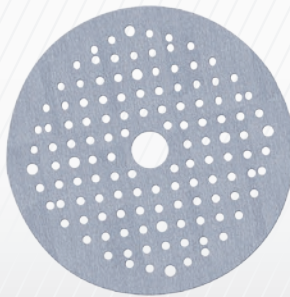

**MULTI-AIR+**

### FEATURES

- Norton SG ceramic abrasive blended with premium heat treated aluminium oxide abrasive
- Unique – blue fibre-reinforced latex paper
- Water based No-Fil
- No pigment in No-Fil or bond
- Improved performance
- Ideal for large surface areas
- Available in grits P80-800

### BENEFITS

- Higher & faster cut rate
- Consistent & uniform scratch pattern
- Combines flexibility with tear resistance
- Resists clogging during use
- No risk of colour transfer
- Extended life
- Less downtime

## MULTI-AIR NORZON H835

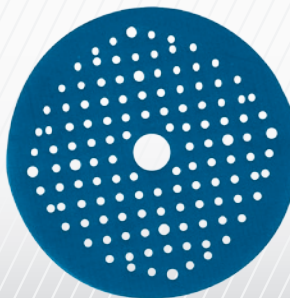

**MULTI-AIR**  
WITH NORZON TECHNOLOGY

### FEATURES

- Latest Norzon grain design
- High strength paper backing (E-weight)
- Open grain distribution
- Full resin bond system

### BENEFITS

- Self-sharpening grain
- Improved cut rate, higher productivity
- Extended product life
- Reduces curling & edge chipping
- Tear resistant
- Prevents premature clogging
- Strong & improved grain adhesion



## MULTI-AIR PLUS WITH SOFT-TOUCH TECHNOLOGY A975

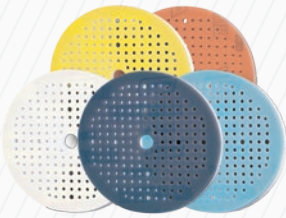

### FEATURES

- Norton SG ceramic blended with premium heat-treated aluminium oxide grain
- Blue fibre reinforced latex paper
- Waterbased No-Fil coating
- No pigment in No-Fil or bond system
- Flexible and coloured Self-Grip foam backing
- Multi-Air hole configuration
- Colour coded discs

### BENEFITS

- Faster cut rate
- Improved performance
- Flexible & tear resistant
- Improved load resistance
- No risk of colour transfer
- Allows contour sanding without cutting through
- Maximum dust extraction for a clean work surface and increased life
- Easy product identification

COATED  
ABRASIVES  
& BEARTEX

BONDED  
ABRASIVES

SUPER  
ABRASIVES

DIAMOND  
TOOLS

CLEANING,  
POLISHING  
& MASKING

PERSONAL  
PROTECTION  
EQUIPMENT

TECHNICAL  
INFORMATION



## MULTI-AIR SOFT-TOUCH A275

BETTER ++++

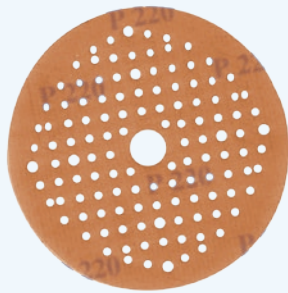
**MULTI-AIR**  
SOFT TOUCH



## FEATURES

- Premium, heat treated aluminium oxide abrasive
- Unique fibre-reinforced latex paper
- Water based No-Fil
- No pigment in No-Fil or bond system
- Flexible foam backing with coloured Self-Grip
- Multi-Air hole configuration
- Colour coded discs
- Available in grits P320-1500

## BENEFITS

- Faster cut rate
- Improved performance
- Flexible & tear resistant
- Improved load resistance
- No risk of colour transfer
- Allows contour sanding without cutting through coating layer
- Maximum dust extraction for a clean work surface & longer life
- For easy recognition of grit size
- Also available in Multi-Air Plus

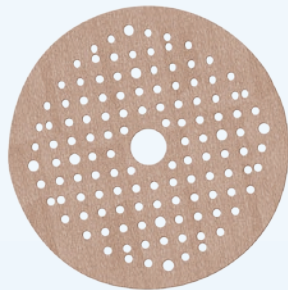
## MULTI-AIR A275

**MULTI-AIR**

## FEATURES

- Premium, heat-treated aluminium oxide abrasive
- Unique fibre-reinforced latex paper
- Water based No-Fil
- No pigment in No-Fil or bond
- Available in grits P80-800

## BENEFITS

- Faster cut rate
- Flexible & tear resistant
- Improved load resistance
- No risk of colour transfer



VIDEO LINK



## AUTOMOTIVE APPLICATION VIDEOS

See the products in use in our Norton application videos.

## VIDEO PLAYLIST:



- Sanding Clearcoat & Polishing
- Norton Paint System
- Masking Preparation
- Headlight Repair
- Body Preparation





**MULTI-AIR SELF-GRIP<sup>†</sup> DISCS**



DIM DIAxH(mm)	GRIT	PK QTY	BOX QTY	MULTI-AIR PLUS A975	MULTI-AIR NORZON	MULTI-AIR A275
				BEST		BETTER
125x18 	80	100	400	63642563535		63642563513
	120	100	400	63642563536		63642563514
	150	100	400	63642563537		63642563515*
	180	100	400	63642563538		63642563516*
	220	100	400			63642563517*
	240	100	400	63642563540		63642563518
	280	100	400	63642563541*		
	320	100	400	63642563542		63642563520
	400	100	400	63642563543		63642563522
	500	100	400	66254477930		63642563523
	600	100	400			63642563524*
800	100	400	66254477934		63642563525	
150x18 	40	50	200		66261086898	
	60	50	200		66261086903	
	80	50	200		66261181412	
	80	100	400	63642565916		63642560561
	120	100	400	63642523429	66261086905	63642560562
	150	100	400	63642523430		63642560563
	180	100	400	63642565920		63642560564
	220	100	400	63642523434		63642560565
	240	100	400	63642523435		63642560566
	280	100	400	63642523436		63642560567
	320	100	400	63642523437		63642560568
	360	100	400			63642560569
	400	100	400	63642565925		63642560570
	500	100	400	66254477924		63642560571
	600	100	400	63642532657 <b>NEW</b>		63642560572
	800	100	400	66254477926		63642560573

\* Made-to-order

**Dimensions Key:** DIM = Dimensions, DIA = Diameter, H = Hole

† To help better describe the abrasive fixing system we have changed the name from 'NorGrip' to 'Self-Grip'.

COATED  
ABRASIVES  
& BEARTEX

BONDED  
ABRASIVES

SUPER  
ABRASIVES

DIAMOND  
TOOLS

CLEANING,  
POLISHING  
& MASKING

PERSONAL  
PROTECTION  
EQUIPMENT

TECHNICAL  
INFORMATION

## MULTI-AIR SOFT-TOUCH



DIM DIAxH(mm)	GRIT	COLOUR	PK QTY	BOX QTY	MULTI-AIR PLUS A975		MULTI-AIR A275
					BEST	BETTER	
150x18 	220	Red	20	120	66261110863	<b>NEW</b>	66261032770*
	320	Salmon	20	120	63642595575		66261032772
	400	Yellow	20	120	63642595577		66261032773
	500	Dark Blue	20	120	66254477927		66261032774
	800	Turquoise	20	120	66254477932		66261032775
	1000	White	20	120	63642536301		66261034247
	1500	Green	20	120	66261110864	<b>NEW</b>	66261034248

\* Made-to-order

## PRODUCT SELECTION GUIDE

APPLICATION	GRIT	COLOUR
SOFT-TOUCH DISCS		
Sanding of filler before primer	220	Red
Sanding cathaphoretic coats & primer	320	Salmon
Sanding polyurethane primer	400	Yellow
	500	Dark Blue
Cutting back lacquer before a flush joint	800	Turquoise
Retouching clear coat	1000	White
Before polishing & buffing	1500	Green



### SPEC CHECK

- Multi-Air Soft-Touch discs are made with a specific soft foam backing with high performance & exceptional long life, directly attached to the abrasive paper
- The foam layer absorbs easily any difference in surface, maintaining an excellent cutting action with a very homogenous, high level finish

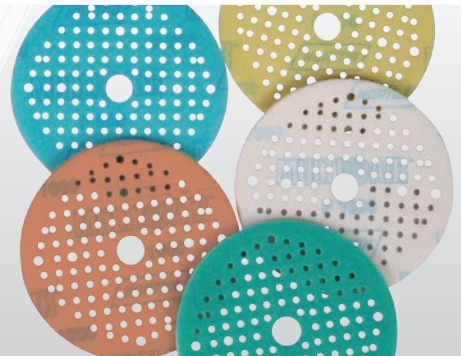



## MULTI-AIR PLUS STARTER KIT



### MULTI-AIR PLUS A975

DIA (mm)	GRIT	TYPE	PK QTY	BEST	
150	80	Multi-Air Plus	5	69957395370	
	120	Multi-Air Plus	5		
	240	Multi-Air Plus	5		
	320	Multi-Air Plus	5		
		Multi-Air Plus Soft-Touch	3		
	400	Multi-Air Plus	5		
		Multi-Air Plus Soft-Touch	3		
	800	Multi-Air Plus Soft-Touch	3		
	Medium Multi-Air Back-up Pad	1			

## MULTI-AIR STARTER KIT



### MULTI-AIR A275

DIA (mm)	GRIT	TYPE	PK QTY	BETTER	
150	80	Medium Multi-Air Norzon	5	63642587576	
	120	Multi-Air	5		
	240	Multi-Air	5		
	320	Multi-Air	5		
	400	Multi-Air	5		
		Multi-Air Soft-Touch	3		
	500	Multi-Air Soft-Touch	3		
	800	Multi-Air Soft-Touch	3		
		Medium Multi-Air Back-up Pad	1		

**Dimensions Key:** DIM = Dimensions, DIA = Diameter, H = Hole

## DEFECT GUIDE COAT



Using Norton Defect Guide Coat before sanding primer will allow better identification of superficial imperfections and ensure the total area is sanded prior to top coat.

VOLUME	ART. NO.	PK QTY
100g	77696072696	6

COATED  
ABRASIVES  
& BEARTEX

BONDED  
ABRASIVES

SUPER  
ABRASIVES

DIAMOND  
TOOLS

CLEANING,  
POLISHING  
& MASKING

PERSONAL  
PROTECTION  
EQUIPMENT

TECHNICAL  
INFORMATION

## BACK-UP PADS MULTI-AIR PROCESS

DIM (mm)	DENSITY	ATTACHMENT	PK QTY	ART. NO.
125	Medium	5/16 & M8	1	63642563533
	Soft	5/16 & M8	1	63642563534
	Medium HT**	5/16 Fixed Screw	1	66261067436
150	Hard	5/16 & M8	1	07660719198
	Medium HT	5/16 & M8	1	63642585872
	Medium HT**	5/16 Fixed Screw	1	63642582245
	Soft	5/16 & M8	1	63642560605
	Rupes Adapter	M5	1	63642526648*

\* Made-to-order

\*\* Designed for Hutchins. Also compatible for most common brands such as Dynabrade, Rupes (except Festool).

5/16 Fixed screw backup pad includes a molded screw for greater pad resistance and stability. All other Multi-Air Process back-up pads are packed in individual boxes with Festo adapter M8 & 5/16 bolts & three fibre ring spaces.

## FOAM INTERFACE PADS MULTI-AIR PROCESS



DIM (mm)	PK QTY	ART. NO.
125	16	63642585864
150	12	07660719359

## PRODUCT SELECTION

APPLICATION	DENSITY
BACK-UP PADS	
Heavy duty sanding, best for flattening surfaces or dimensioning	Hard
Scuffing, shaping, sanding & finishing	Medium
For use on filler, primer, paint, clear coat, wood, plaster, composites & metal	
Final sanding, to obtain the best finishes	Soft

## KIT MULTI-AIR SANDING BLOCK



	DIM DIAxH(mm)	PK QTY	ART. NO.
 x1 BLOCK	 x3 INTERFACE	 150x18	1 077696024493

Manual sanding block with a set of 3 velcro interchangeable plates (plane, concave and convex) to be used with Multi-Air discs, also Soft-Touch version. With air valve for better aspiration.

**Dimensions Key:** DIM = Dimensions, DIA = Diameter



## SELF-GRIP<sup>†</sup> & SOFT-TOUCH DISCS

Self-Grip<sup>†</sup> discs have a quick release backing that allows quick and easy disc changing, increasing performance by minimising downtime. Soft-Touch discs also include a foam backing that improves product performance and gives an even longer product life. The foam layer absorbs unevenness in the surface, helping to maintain an excellent cutting action providing a very homogenous, high quality finish.

### APPLICATIONS & MARKETS

- Preparing primed & painted surfaces
- Stripping primer & paint
- Sanding plastic & fibreglass
- Light weld blending & deburring
- Sanding bare wood



COATED  
ABRASIVES  
& BEARTEX

BONDED  
ABRASIVES

SUPER  
ABRASIVES

DIAMOND  
TOOLS

CLEANING,  
POLISHING  
& MASKING

PERSONAL  
PROTECTION  
EQUIPMENT

TECHNICAL  
INFORMATION

### NEW NORTON ICE Q255

BEST +++++

INNOVATION

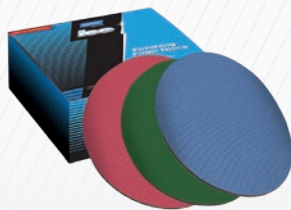

FERR.  
& NON  
FERR.



PAINT/VARN.  
& HARD WOOD

**ice**



#### FEATURES

- Ultra fine grits with color code for friendly use: 1500 - blue, 2000 - fushia, 3000 - green
- Uniformed cut throughout product life span
- Washable and waterproof
- NEW abrasive technology

#### BENEFITS

- Foam backing absorbs water and moulds to the surface for equal pressure distribution
- Smooth finish and lower scratch depth
- Requires less effort during the application
- High quality finish

<sup>†</sup> To help better describe the abrasive fixing system we have changed the name from 'NorGrip' to 'Self-Grip'.



**NEW** PURE ICE FILM DISCS Q175**BEST +++++****PUREice™**

A strong, thin film backing with premium aluminium oxide abrasive and a patented resin technology sands flat, resists loading, lasts long and cuts consistently for a finish that's faster to buff out. A superior no-fil coating means loading is minimised for even longer sanding life.

**FEATURES**

- Patented resin technology
- Consistent, water-based No-Fil stearate application
- Ultra-thin film backing for maximum flexibility
- R&D integral design of film backing and unique resin system
- Colour coded grits

**BENEFITS**

- Excellent grain adhesion for long life and consistent cut
- Resists loading to extend disc life and eliminate pigtails
- Even surface provides a very consistent finish that is easier to buff out
- Can conform to irregular surfaces
- Discs stay flat for a superior surface finish
- Easy identification of grit and application

**MOUNTING**

For better results, use with the Norton Soft interface pad.  
For detailed information see page 193.

**DRY ICE FILM Q260****DRYice™****FEATURES**

- Anti-loading agent
- Consistent finish
- Fast cut
- Smooth film backing
- Long life

**BENEFITS**

- Eliminates pig tails and costly re-work
- Quick and easy to buff out
- Increase productivity
- Consistent finish that buffs out faster
- Less downtime switching discs
- Reduce material and labor costs



## NORTON PRO PLUS A975

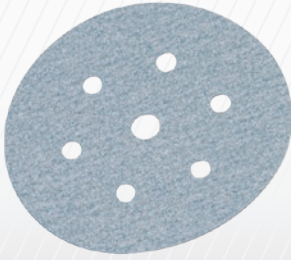

**PRO+**



### FEATURES

- Norton SG ceramic abrasive blended with premium heat-treated aluminium oxide abrasive
- Unique blue fibre-reinforced latex paper
- Water based No-Fil, no pigment
- Available in Soft-Touch

### BENEFITS

- Higher & faster cut rate with uniform scratch pattern
- Flexible and tear resistance
- Resists clogging during use and no risk of colour transfer
- Extended life

COATED ABRASIVES & BEARTEX

BONDED ABRASIVES

## BLUE FIRE NORZON H835

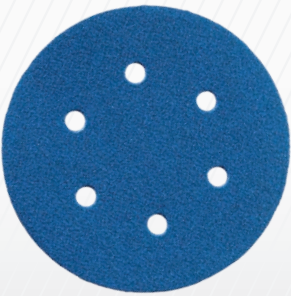

**BLUEfire**



### FEATURES

- Latest Norzon grain design
- High strength paper backing (E-weight)
- Open grain distribution
- Full resin bond system
- Available in grits 40-120

### BENEFITS

- Self-sharpening grain
- Improved cut rate
- Extended product life
- Reduces curling & edge chipping
- Tear resistant
- Prevents premature clogging
- Strong grain adhesion

SUPER ABRASIVES

DIAMOND TOOLS

CLEANING, POLISHING & MASKING

PERSONAL PROTECTION EQUIPMENT

TECHNICAL INFORMATION



VIDEO LINK



## AUTOMOTIVE APPLICATION VIDEOS

See the products in use in our Norton application videos.

### VIDEO PLAYLIST:

- Sanding Clearcoat & Polishing
- Norton Paint System
- Masking Preparation
- Headlight Repair
- Body Preparation

## NORTON PRO A275

BETTER ++++

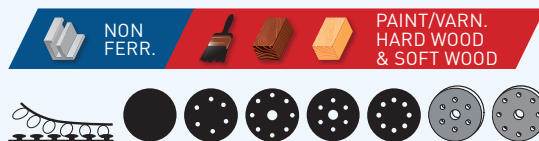
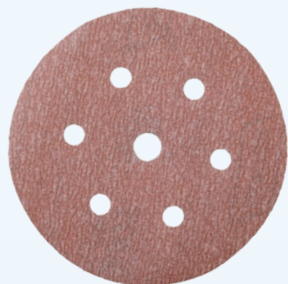

PRO

## FEATURES

- Premium, heat-treated high performance aluminium oxide abrasive
- Unique fibre-reinforced latex paper
- Water based No-Fil
- No pigment in No-Fil or bond
- Available in Soft-Touch with flexible foam backing & coloured Self-Grip
- Available in Self-Grip grits P80-1500 & Soft-Touch Self-Grip grits P220-1500

## BENEFITS

- Faster cut rate
- Improved performance
- More consistent uniform scratch pattern
- Flexible & tear resistant
- Improved load resistance
- No risk of colour transfer
- Allows contour sanding without cutting through coating layer & easy grit identification

## NEW NORTON PRO FILM Q275

PRO  
FILM

## FEATURES

- Heat-treated aluminium oxide grain
- FEPA 'P' graded abrasive
- Waterbased No-Fil stearate layer on the abrasive
- Flexible film backing
- Self-gripping backing
- Full range of grits available

## BENEFITS

- Fast cut, good material removal and excellent performance
- Approved, high quality discs
- Prevents dust build-up during sanding
- For dry sanding
- Provides a consistent scratch pattern, reduces rework
- Tear resistant
- Quick & easy disc changing, reduce process time
- A product for every application stage



## SPEC CHECK

- Norton Pro Soft-Touch discs are made with a specific soft foam backing with high performance & exceptional long life, directly attached to the abrasive paper
- The foam layer absorbs easily any difference in surface, maintaining an excellent cutting action with a very homogenous, high quality finish





## H231



### FEATURES

- High performance aluminium oxide abrasive
- Semi-open / open coat (depending on grit size)
- Very strong, F-weight paper
- Anti-static properties

### BENEFITS

- Ideal for roughing, intermediate sanding & finishing of solid wood
- Ideal for floor & furniture applications
- Finer grits ideal for polishing metal, plastics & leathers, smoothing fillers, sanding primers, within vehicle repair markets
- Resists clogging
- High performance
- Excellent surface quality

COATED ABRASIVES & BEARTEX

BONDED ABRASIVES

## GOLD RESERVE A296

GOOD +++



**GOLD RESERVE**<sup>+</sup>

### FEATURES

- "P" graded premium aluminium oxide grain
- Strong B weight latex/paper backing
- Water-based, non-loading stearate
- Available in Self-Grip grits P80-P800 & Soft-Touch Self-Grip grits P320-P800

### BENEFITS

- Produces a quick, cool cut
- Produces a more consistent scratch pattern
- Resists tearing
- Conformable and flexible
- Resists loading
- Increases productivity

SUPER ABRASIVES

DIAMOND TOOLS

CLEANING, POLISHING & MASKING

PERSONAL PROTECTION EQUIPMENT

TECHNICAL INFORMATION

# SELF-GRIP<sup>+</sup> DISCS



COATED  
ABRASIVES  
& BEARTEX

BONDED  
ABRASIVES

SUPER  
ABRASIVES

DIAMOND  
TOOLS

CLEANING,  
POLISHING  
& MASKING

PERSONAL  
PROTECTION  
EQUIPMENT

TECHNICAL  
INFORMATION

DIM DIAXH(mm)	GRIT	PK QTY	BOX QTY	NORTON ICE Q255	BLUE FIRE H835	PURE ICE Q175	DRY ICE Q260	NORTON PRO A275	H231
				BEST INNOVATION	BEST			BETTER	
76	80	50	100					63642585133	
	150	50	100					63642585148	
	180	50	100					63642585150	
	220	50	100					63642585153	
	240	50	100					63642585156	
	320	50	100					63642569699	
	400	50	100					63642585169	
	500	50	100					69957391303	
	800	50	100					63642585172	
	1000	50	100				66261110859	66254405679	63642585180
1500	50	100				66261110860	66254405681		
80	1500	12	48	66623324958					
	2000	12	48	66623324955					
	3000	12	48	66623324956					
125	36	100							66261176734
	60	100							63642516174
	80	100							63642516175
	120	100							63642516176
	180	100							63642537389
	240	100							69957360184
	320	100							63642537390
150	36	50							63642551458
	40	100							63642531875
	40	25	25		69957390933				
	50	100							69957360119
	60	100							63642519158
	60	25	25		69957390940				
	80	100						63642585184	63642546787
	80	50	50		69957391248				
	100	100						63642585186	63642531872
	120	100						63642569701	63642531871
	120	50	50		69957391249				
	150	100						63642569702	69957360170
	180	100						63642585190	63642536755
	220	100						63642585194	
	240	100						63642585197	63642546797
	280	100						63642585199*	
	320	100						63642569704	
	360	100						63642585205*	
	400	100						63642585214	
	500	100						63642585217	
600	100						63642585220		
800	100						63642585223		
1000	50	300					66254405675**		
1500	50	300					66254405677**		
1500	15	60	66623324933						
2000	15	60	66623324952						
3000	15	60	66623324954						

\* Made-to-order \*\* 150mm x 18 Multi-Air

† To help better describe the abrasive fixing system we have changed the name from 'NorGrip' to 'Self-Grip'.









**SELF-GRIP<sup>+</sup> DISCS**



DIM DIAxH(mm)	GRIT	PK QTY	BOX QTY	BLUE FIRE H835	NORTON PRO PLUS A975	PURE ICE Q175	DRY ICE Q260	NORTON PRO A275	H231
				BEST					BETTER
150  7 holes	40	100							66261026066
	40	25		69957391250					
	60	100							69957382764
	60	25		69957391255					
	80	100	400		63642527655			63642557950	66261026069
	80	50		69957391256					
	100	100	400					63642586135	66261026070
	120	100	400		63642527659			63642557954	66261026071
	120	50		69957391257					
	150	100	400		63642527657			63642586141	66261026072
	180	100	400		63642527661			63642586142	69957351530
	220	100	400		63642527662			63642586143	
	240	100	400		63642527666			63642557955	69957351531
	280	100	400		63642527667			63642586144	
	320	100	400		63642527669			63642557959	
	360	100	400					63642586148	
	400	100	400		63642527670			63642557962	
	500	100	400		66254476604			63642586150	
	600	100	400		66261108636			63642557964	
	800	100	400		66254476617			63642584990	
800	50	300			66261110841	66623303904			
1000	50	300			66261110852	66261072192			
1200	50	300			66261110853	66254403620			
1500	50	300			66261110854	66261072193			
150  9 holes	40	100							63642550341
	40	25		69957391258					
	60	100							63642536740
	60	25		69957391260					
	80	100	400		63642527612			63642557968	63642536741
	80	50		69957391261					
	100	100	400					63642585059	63642568763
	120	100	400		63642565918			63642557969	63642546779
	120	50		69957391262					
	150	100	400		63642565919			63642557970	63642546781
	180	100	400		63642527633			63642585064	63642546834
	220	100	400		63642565921			63642585065	
	240	100	400		63642565922			63642585067	
	280	100	400		63642565923			63642585069	
	320	100	400		63642565924			63642557973	
	360	100	400					63642585078	
	400	100	400		63642527647			63642557974	
	500	100	400		66254477132			63642557975	
	600	100	400		66261108637			63642585073	
	800	100	400		66254477133			63642585074	
800	50	300			66261110837	66623303896			
1000	50	300			66261110838	66261072195			
1200	50	300			66261110839	66623300928			
1500	50	300			66261110840	66261072196			

COATED  
ABRASIVES  
& BEARTEX

BONDED  
ABRASIVES

SUPER  
ABRASIVES

DIAMOND  
TOOLS

CLEANING,  
POLISHING  
& MASKING

PERSONAL  
PROTECTION  
EQUIPMENT

TECHNICAL  
INFORMATION

**NEW**



**Dimensions Key:** DIM = Dimensions, DIA = Diameter, H = Hole

# SELF-GRIP<sup>+</sup> DISCS



**BLUE FIRE** H835   
 **NORTON PRO PLUS** A975   
 **PURE ICE** Q175   
 **DRY ICE** Q260   
 **NORTON PRO** A275   
 **NORTON PRO FILM** Q275   
 **GOLD RESERVE** A296

DIM DIAxH(mm)    GRIT    PK QTY    BOX QTY   
 **BEST**    **BETTER**    **GOOD**

COATED ABRASIVES & BEARTEX  BONDED ABRASIVES  SUPER ABRASIVES  DIAMOND TOOLS  CLEANING, POLISHING & MASKING  PERSONAL PROTECTION EQUIPMENT  TECHNICAL INFORMATION	 150 15 holes	40	50		66254444904																
		60	50		66254444905																
		80	100	400		66254477881				66254405540	77696088579	66261097523									
		80	50		66254444908																
		100	100	400						66254405542											
		120	100	400		66254477879				66254405528	77696088028	66261097529									
		120	50		66254444909																
		150	100	400		66254477882				66254405530	77696088145	66261097531									
		180	100	400		66254477883				66254405546	77696088146	66261097532									
		220	100	400		66254477884				66254405548	77696088147	66261097533									
		240	100	400		66254477885				66254405549	77696088149	66261097534									
		280	100	400		66254477886				66254405550		66261097537									
		320	100	400		66254477887				66254405539	77696088150	66261097538									
		360	100	400						66254405551											
		400	100	400		66254477888				66254405552	77696088151	66261097539									
		500	100	400		66254476601				66254405553	77696088152	66261097540									
		600	100	400		63642532659				66254405554	77696088153	66261097542									
		800	100	400		66254479091				66254405555	77696088154	66261097543									
		800	50	300					66261110855	66623305249											
		1000	50	300					66261110856	66623311271											
1000	100	400								77696088155											
1200	50	300					66261110857	66623311275													
1200	100	400								77696088156											
1500	50	300					66261110858	66623311277													
1500	100	400								77696088388											
150x18 	1000	50	300				66261113819**														
	1500	50	300				66261113821**														
203  203 8 holes	40	25		69957391263																	
	60	25		69957391268																	
	80	50		69957391269	66261111705																
	120	100								63642585243											
	120	50		69957391272	66261111708																
	150	100			66261111709					63642585244											
	180	100			66261111710					63642585245											
	220	100			66261111713																
	240	100			66261111714					63642585248											
	320	100			66261111715					63642585250											
400	100			66261111717					63642585252*												

**NEW**

\* Made-to-order \*\* 150mm x 18 Multi-Air

† To help better describe the abrasive fixing system we have changed the name from 'NorGrip' to 'Self-Grip'.



## SOFT-TOUCH DISCS



DIM DIAxH(mm)	GRIT	COLOUR	PK QTY	BOX QTY	NORTON PRO	GOLD RESERVE
					A275	A296
					BETTER	GOOD
 150 7 holes	220	Red	20	80	63642557535	
	320	Salmon	20	80	63642557543*	
	400	Yellow	20	80	63642557546*	
	500	Dark Blue	20	80	63642557548	
	600	Fuchsia	20	80	63642557550	
	800	Turquoise	20	80	63642557551	
	1000	White	20	80	63642557556	
	1500	Green	20	80	63642557559	
 150 9 holes	400	Yellow	20	80	63642557569	
	500	Dark Blue	20	80	63642557570	
	600	Fuchsia	20	80	63642557572	
	800	Turquoise	20	80	63642557571	
	1000	White	20	80	63642557573	
	1500	Green	20	80	63642557574	
 150 15 holes	320	Salmon	20	80	66623382800	
		White	20	80		66261097551
	400	Yellow	20	80	66623382802	
		White	20	80		66261097554
	500	Dark Blue	20	80	66623382803	
		White	20	80		66261097556
	600	Turquoise	20	80	66623382804	
	800	White	20	80		66261097557
	1000	White	20	80	66623382806	
	1500	Green	20	80	66623382808	

\* Made-to-order

**Dimensions Key:** DIM = Dimensions, DIA = Diameter, H = Hole

## PRODUCT SELECTION

APPLICATION	GRIT	COLOUR
SOFT-TOUCH DISCS		
Sanding of filler before primer	220	Red
Sanding of cataphoretic primer	320	Salmon
Sanding of polyurethane primer	400	Yellow
	500	Dark Blue
	600	Fuchsia
Cutting back lacquer before a flush joint	800	Turquoise
Retouching clear coat	1000	White
Before polishing & buffing	1500	Green

COATED  
ABRASIVES  
& BEARTEX

BONDED  
ABRASIVES

SUPER  
ABRASIVES

DIAMOND  
TOOLS

CLEANING,  
POLISHING  
& MASKING

PERSONAL  
PROTECTION  
EQUIPMENT

TECHNICAL  
INFORMATION

BEARTEX SELF-GRIP<sup>†</sup> DUST HOLE DISCS

GOOD +++



## FEATURES

- Flexible
- Gentle action
- Non-loading and ideal for finishing solid surface materials
- Resilient construction

## BENEFITS

- Conforms to work surface & provides a uniform finish
- Easily removes burrs without affecting the dimension of the workpiece
- Continual supply of new cutting edges
- Long life, waterproof & solvent resistant

DIA (mm)	CAP CODE	GRADE	PK QTY	ART. NO.
150	F2520	Very Fine A	10	69957383151
	F4804	Ultra Fine S	10	69957383158
	F2801	Micro Fine A	10	69957383162

BEARTEX SELF-GRIP<sup>†</sup> PLAIN DISCS

DIA (mm)	CAP CODE	GRADE	PK QTY	BETTER	GOOD
150	F2316	MED A Heavy Duty	20	66261121312	
	F2560	Very Fine A	10		63642574240
	F4660	Ultra Fine S	10		63642581769



**Dimensions Key:** DIM = Dimensions, DIA = Diameter, H = Hole

<sup>†</sup> To help better describe the abrasive fixing system we have changed the name from 'NorGrip' to 'Self-Grip'.



## SPEC CHECK

- Norton has the capability to convert Jumbo rolls into a wide variety of shapes & sizes for your individual application.
- Please contact your local Norton Sales Representative for further information.



## BACK-UP PADS

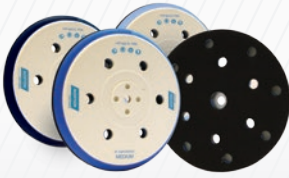

### FEATURES

- Different densities, available in most popular perforations/dust hole patterns
- New back plate technology
- Attachments for different tools
- Easy-peel technology
- Colour coding of foam layer

### BENEFITS

- Applies to a full range of applications with optimal dust extraction
- Heavy duty design
- Long life
- Adapts to all common orbital sanders
- Longer life of gripping layer
- Easy & quick hardness identification

## BACK-UP PADS

DENSITY	COLOUR	APPLICATION
HARD	BLUE rubber	Heavy duty sanding, best for flattening surfaces or dimensioning
MEDIUM	BLACK rubber	Scuffing, shaping, sanding & finishing. For use on filler, primer, paint, clear coat, wood, plaster, composites & metal
SOFT	ORANGE foam/rubber	Final sanding, to obtain the best finishes

Packed in clear individual display box including: safety recommendations, product information, mounting instructions, versatile attachment system (Festool M8 and standard 5/16) and allen wrench

## SELF-GRIP<sup>+</sup> DUO



Self-Grip<sup>+</sup> Duo

A universal attachment system for both Self-Grip<sup>+</sup> and self-adhesive discs provides the maximum flexibility and optimal finishing results. The Self-Grip<sup>+</sup> DUO combines an innovative design of gripping structures in the shape of flat-top mushrooms which provides a highly uniform finish while allowing both self-adhesive and Self-Grip<sup>+</sup> discs to be used on this unique system.

### FEATURES

- New gripping technology
- Engineered gripping structure
- Excellent resistance to peeling

### BENEFITS

- Uniform surface for better finishing
- Reduced scratching
- No change in backing pad required



Self-Grip<sup>+</sup> standard

† To help better describe the abrasive fixing system we have changed the name from 'NorGrip' to 'Self-Grip'.

COATED ABRASIVES & BEARTEX

BONDED ABRASIVES

SUPER ABRASIVES

DIAMOND TOOLS

CLEANING, POLISHING & MASKING









PERSONAL PROTECTION EQUIPMENT

TECHNICAL INFORMATION



## BACK-UP PADS SELF-GRIP<sup>†</sup>



DIA (mm)	DENSITY	ATTACHMENT	PK QTY	ART. NO.
115 	Medium	M14	3	69957350743
125 	Medium	5/16"	3	69957350739
125 	Medium	M14	3	69957350744
150 	Medium	M14	3	63642567812
150 	Medium	5/16 & M8	1	66623338436
150 	Hard	5/16 & M8	1	66623338446
	Medium	5/16 & M8	1	66623338445
	Soft	5/16 & M8	1	66623338441*
150 	Hard	5/16 & M8	1	66623338449
	Medium	5/16 & M8	1	66623338448
	Soft	5/16 & M8	1	66623338447*
150 	Hard	5/16 & M8	1	66623338451
	Medium	5/16 & M8	1	66623338450
	Soft	5/16 & M8	1	66623338452
203 	Medium	M5	1	69957371442*

\* Made-to-order

<sup>†</sup> To help better describe the abrasive fixing system we have changed the name from 'NorGrip' to 'Self-Grip'.



## PRODUCT SELECTION GUIDE

ATTACHMENT TYPE	MACHINE
BACK-UP PADS	
M14	Electrical angle grinder
5/8"	Electrical & pneumatic grinders (US tools)
M8	Festo orbital sander
5/16"	Other orbital sanders
M6	Mirka or CP orbital sander
M5	Rupes orbital sander



### BACK-UP PADS SELF-GRIP<sup>†</sup> DUO







DIA (mm)	DENSITY	ATTACHMENT	PK QTY	ART. NO.
33 	Medium	5/16	6	63642567811*
76 	Medium	5/16	6	63642567810

\* Made-to-order

### FOAM INTERFACE BACK-UP PADS SELF-GRIP<sup>†</sup>



DIA (mm)	PK QTY	ART. NO.
76 	10	69957394589
150 	10	07660707383
150 	10	69957394590
150 	10	07660719360



**Dimensions Key:** DIA = Diameter

COATED  
ABRASIVES  
& BEARTEX

BONDED  
ABRASIVES

SUPER  
ABRASIVES

DIAMOND  
TOOLS

CLEANING,  
POLISHING  
& MASKING

PERSONAL  
PROTECTION  
EQUIPMENT

TECHNICAL  
INFORMATION



#### SPEC CHECK

- Specially designed to give optimal results with very fine grit abrasives, the Norton foam interfaces easily conforms to contours. These are specifically developed for the finishing operation to reduce any risk of scratching
- Self-Grip<sup>†</sup> discs can be used with the Self-Grip<sup>†</sup> hand pad for manual application

<sup>†</sup> To help better describe the abrasive fixing system we have changed the name from 'NorGrip' to 'Self-Grip'.

# SELF-ADHESIVE DISCS

Norton Premium quality self-adhesive discs can be securely fixed onto suitable back-up pads.

## APPLICATIONS & MARKETS

- Preparing primed & painted surfaces
- Stripping primer & paint
- Sanding plastic & fibre-glass
- Light weld blending & deburring
- Finishing metal



COATED  
ABRASIVES  
& BEARTEX

BONDED  
ABRASIVES

SUPER  
ABRASIVES

DIAMOND  
TOOLS

CLEANING,  
POLISHING  
& MASKING

PERSONAL  
PROTECTION  
EQUIPMENT

TECHNICAL  
INFORMATION

## H231

BETTER ++++



### FEATURES

- High performance aluminium oxide abrasive
- Semi-open / open coat (depending on grit size)
- Very strong, F-weight paper
- Anti-static properties

### BENEFITS

- Ideal for roughing, intermediate sanding & finishing of solid wood
- Ideal for floor & furniture applications
- Finer grits ideal for polishing metal, plastics & leathers, smoothing fillers, sanding primers, within vehicle repair markets
- Resists clogging
- High performance
- Excellent surface quality

## BLACK ICE T401



**BLACK**  
*ice*

### FEATURES

- Premium, ultra fine silicon carbide abrasive
- Advanced resin bond system
- Advanced, A-Weight waterproof paper backing design
- Supplied in rolls of 400 discs

### BENEFITS



- Best finish in wet clear-coat repair applications
- Longer life in wet applications
- Waterproof
- Ultimate flexibility & waterproof performance
- Convenient & easy to store



## SELF-ADHESIVE DISCS

### BLACK ICE T401

H231

DIA (mm)	GRIT	PK QTY	BETTER	
 38	1500	400	63642534470	
	2000	400	69957360371	
	2500	400	63642561155	
 150	40	100		69957360111
	60	100		63642536719*
	80	100		63642528522
	100	100		63642536724
	120	100		63642536725

\* Made-to-order

**Dimensions Key:** DIA = Diameter

COATED  
ABRASIVES  
& BEARTEX

BONDED  
ABRASIVES

SUPER  
ABRASIVES

DIAMOND  
TOOLS

CLEANING,  
POLISHING  
& MASKING

PERSONAL  
PROTECTION  
EQUIPMENT

TECHNICAL  
INFORMATION



VIDEO LINK



### AUTOMOTIVE APPLICATION VIDEOS

See the products in use in our Norton application videos.

#### VIDEO PLAYLIST:

- Sanding Clearcoat & Polishing
- Norton Paint System
- Masking Preparation
- Headlight Repair
- Body Preparation



#### SPEC CHECK

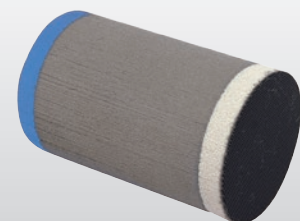

- Designed to be used by hand with the maximum flexibility and versatility, the 38mm double-sided sanding block has two sides with different hardness: one for cutting, one for finishing.

Pack quantity 12      63642567819



## BACK-UP PADS SELF-ADHESIVE DISCS



DIA (mm)	DENSITY	ATTACHMENT	PK QTY	ART. NO.
150 	Medium	5/16 & M8	1	63642594551*
150 	Medium	5/16 & M8	1	63642594552*

\* Made-to-order

**Dimensions Key:** DIA = Diameter

## PRODUCT SELECTION GUIDE FOR NORTON DISCS

MATERIALS / APPLICATIONS		HIGHLY RECOMMENDED	RECOMMENDED	SUITABLE
Metal		Multi-Air Norzon	Multi-Air Plus	
Wood	Coarse Sanding	Multi-Air Norzon	Multi-Air Plus	A275
	Finishing	A975	A275 / Q275	Gold Reserve A296
Filler	Aluminium/Metal	Multi-Air Norzon/ H835	Multi-Air Plus/ A975	Multi-Air/ A275 / Q275
	Polyester	Multi-Air Plus/ A975	Multi-Air Norzon/ H835	
Primer/Paint/Varnish	Coarse Sanding	Multi-Air/A275	Multi-Air/A275	Gold Reserve A296
	Finishing	ICE	Q260	Multi-Air/ A275 / Q275
	Finishing/Spot Repair	ICE	T401	
Composites/Coatings	Epoxy	H835	H231	
	Acrylic	A975	A275	Gold Reserve A296
	Fibre Glass	H835	H231	
	Finishing	A975/ICE	A275 / Q260	
Stone			H425/G422	
Accessories - replacement velcro			Q007	

COATED  
ABRASIVES  
& BEARTEX

BONDED  
ABRASIVES

SUPER  
ABRASIVES

DIAMOND  
TOOLS

CLEANING,  
POLISHING  
& MASKING

PERSONAL  
PROTECTION  
EQUIPMENT

TECHNICAL  
INFORMATION



# 197-208

## ORBITAL STRAIGHT SHEET SANDER/SANDING BLOCK



COATED  
ABRASIVES  
& BEARTEX

BONDED  
ABRASIVES

SUPER  
ABRASIVES

DIAMOND  
TOOLS

CLEANING,  
POLISHING  
& MASKING

PERSONAL  
PROTECTION  
EQUIPMENT

TECHNICAL  
INFORMATION

198 Cut Sheets

205 Self-Grip<sup>†</sup> Paper Rolls

207 Beartex Rolls

<sup>†</sup> To help better describe the abrasive fixing system we have changed the name from 'NorGrip' to 'Self-Grip'.

# CUT SHEETS

Norton offers a full range of cut sheets for hand and machine use, providing a range of efficient, user-friendly abrasive solutions. The extended range of dimensions and grits complies with all commonly encountered applications.

## APPLICATIONS & MARKETS

- Flatten sharp edges & large surface areas
- Deburring
- Removing sanding scratches



COATED  
ABRASIVES  
& BEARTEX

BONDED  
ABRASIVES

SUPER  
ABRASIVES

DIAMOND  
TOOLS

CLEANING,  
POLISHING  
& MASKING

PERSONAL  
PROTECTION  
EQUIPMENT

TECHNICAL  
INFORMATION

## MULTI-AIR PLUS A975

BEST +++++

INNOVATION



**MULTI-AIR+**

### FEATURES

- Norton SG Ceramic abrasive blended with premium heat-treated aluminium oxide
- Unique reinforced latex paper
- Water based No-Fil
- No pigment in No-Fil or bond
- Improved performance
- Ideal for large surface area

### BENEFITS

- Higher & faster cut rate
- Consistent & uniform scratch pattern
- Combines flexibility with tear resistance
- Resists clogging during use
- No risk of colour transfer
- Extended life
- Less downtime

## MULTI-AIR NORZON H835

**MULTI-AIR**  
WITH NORZON TECHNOLOGY



### FEATURES

- Latest Norzon grain design
- High strength paper backing (E-weight)
- Open grain distribution
- Full resin bond system

### BENEFITS

- Self-sharpening grain
- Improved cut rate for higher productivity
- Extended product life
- Reduces curling & edge chipping
- Tear resistant
- Prevents premature clogging
- Strong & improved grain adhesion



## NORTON PRO A275

BETTER ++++

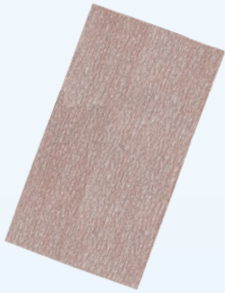

**PRO**

### FEATURES

- Premium, heat-treated high performance aluminium oxide abrasive
- Unique fibre-reinforced latex paper
- Water based No-Fil
- No pigment in No-Fil or bond
- Available in grits 80-1000

### BENEFITS

- Faster cut rate
- Improved performance
- More consistent uniform scratch pattern
- Flexible & tear resistant
- Improved load resistance
- No risk of colour transfer

## G131F

GOOD +++



### FEATURES

- Aluminium oxide abrasive
- E-weight paper backing
- Made with FSC mix certified paper backing

### BENEFITS

- Good performance
- Economy product
- Responsibly sourced



### FSC CERTIFICATION

- Utilising responsibly sourced material and preserving natural resources is a high priority so our coated abrasive plants manufacturing paper backed products are now FSC certified.

COATED ABRASIVES & BEARTEX

BONDED ABRASIVES

SUPER ABRASIVES

DIAMOND TOOLS

CLEANING, POLISHING & MASKING

PERSONAL PROTECTION EQUIPMENT

TECHNICAL INFORMATION

# CUT SHEETS



VIDEO LINK



## AUTOMOTIVE APPLICATION VIDEOS

See the products in use in our Norton application videos.

### VIDEO PLAYLIST:

- Sanding Clearcoat & Polishing
- Norton Paint System
- Masking Preparation
- Headlight Repair
- Body Preparation

## PRODUCT SELECTION GUIDE

MATERIALS / APPLICATIONS	HIGHLY RECOMMENDED	RECOMMENDED	SUITABLE
Metal	H835	H231	A275
Wood	H231	A275	G131F
Filler	H835	A975	A275
Primer/Paint/Varnish	A975	A275	
Composites/Coatings	H835	A975	A275

## PAPER SHEETS

### NORTON PRO A275

G131F



DIM  
WxL(mm)

GRIT

PK  
QTY



BETTER

GOOD

115x280 	40	50		66623372533
	50	50		66623372534
	60	50		66623372575
	80	50	63642588214	66623372576
	100	50		66623372577
	120	50	63642588217	66623372581
	150	50		66623372578
	180	50	63642588221	66623372579
	220	50		66623372580
	240	50	63642588223	
	280	50	63642588224	
	320	50	63642588225	
115x280 	40	50		66623373358
	50	50		66623373357
	60	50		66623373356
	80	50		66623373359
	100	50		66623373360
	120	50		66623373363
	150	50		66623373362



## MULTI-AIR CUT SHEETS

DIM WxL(mm)	GRIT	PK QTY	BOX QTY	MULTI-AIR	MULTI-AIR PLUS
				NORZON H835	A975
BEST INNOVATION					
70x125 	40	50	200	69957394449	
	60	50	200	69957394350	
	80	50	200	69957394355	69957394456
	120	50	200	69957394357	69957394457
	150	50	200		69957394458
	180	50	200		69957394459
	220	50	200		69957396408
	240	50	200		69957394460
	320	50	200		69957394461
	400	50	200		69957394462
70x198 	40	50	200	69957394363	
	60	50	200	69957394367	
	80	50	200	69957394369	69957394470
	120	50	200	69957394451	69957394472
	150	50	200		69957394473
	180	50	200		69957394474
	220	50	200		69957396410
	240	50	200		69957394475
	280	50	200		69957396411
	320	50	200		69957394477
400	50	200		69957394478	
70x420 	40	50	200	69957394450	
	60	50	200	69957394358	
	80	50	200	69957394360	69957394463
	120	50	200	69957394361	69957394464
	150	50	200		69957394465
	180	50	200		69957394466
	220	50	200		69957396406
	240	50	200		69957394467
	280	50	200		69957396407
	320	50	200		69957394468
400	50	200		69957394469	

**Dimensions Key:** DIM = Dimensions, W = Width, L = Length

COATED  
ABRASIVES  
& BEARTEX

BONDED  
ABRASIVES

SUPER  
ABRASIVES

DIAMOND  
TOOLS

CLEANING,  
POLISHING  
& MASKING



PERSONAL  
PROTECTION  
EQUIPMENT

TECHNICAL  
INFORMATION



# CUT SHEETS

## MULTI-AIR CUT SHEETS (CONTINUED)

DIM WxL(mm)	GRIT	PK QTY	BOX QTY	MULTI-AIR NORZON H835	MULTI-AIR PLUS A975
				BEST INNOVATION	
115x230 	40	50	200	69957394452	
	60	50	200	69957394453	
	80	50	200	69957394454	69957394479
	120	50	200	69957394455	69957394481
	150	50	200		69957394482
	180	50	200		69957394483
	220	50	200		69957396414
	240	50	200		69957394484
	280	50	200		69957396415
	320	50	200		69957394485
	400	50	200		69957394486
115x405 	80	50	200		66261066786
	120	50	200		66261066788

Multi-Air cut sheets have similar positioning holes locations as standard perforated sheets that makes them easy to position

## SELF-GRIP<sup>†</sup> CUT SHEETS



DIM WxL(mm)	GRIT	PK QTY	NORTON PRO A275
			BETTER
70x420 	80	100	63642585549
	120	100	63642585555
	180	100	63642585561
	240	100	63642585568
	320	100	63642585576

<sup>†</sup> To help better describe the abrasive fixing system we have changed the name from 'NorGrip' to 'Self-Grip'.



## PLAIN SANDING BLOCK SELF-GRIP<sup>†</sup>



	DIM WxL(mm)	PK QTY	ART. NO.
	70x125	15	07660705180

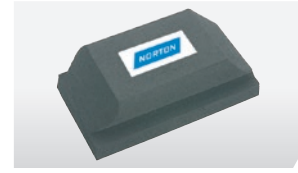

## PERFORATED SANDING BLOCKS SELF-GRIP<sup>†</sup>



	DIM WxL(mm)	PK QTY	ART. NO.
	70x125 	1	69957396645
	70x198 	1	69957396646
	70x400 	1	69957396648
	115x230 	1	69957396644

**Dimensions Key:** DIM = Dimensions, W = Width, L = Length

<sup>†</sup> To help better describe the abrasive fixing system we have changed the name from 'NorGrip' to 'Self-Grip'.

COATED  
ABRASIVES  
& BEARTEX

BONDED  
ABRASIVES

SUPER  
ABRASIVES

DIAMOND  
TOOLS

CLEANING,  
POLISHING  
& MASKING

PERSONAL  
PROTECTION  
EQUIPMENT

TECHNICAL  
INFORMATION

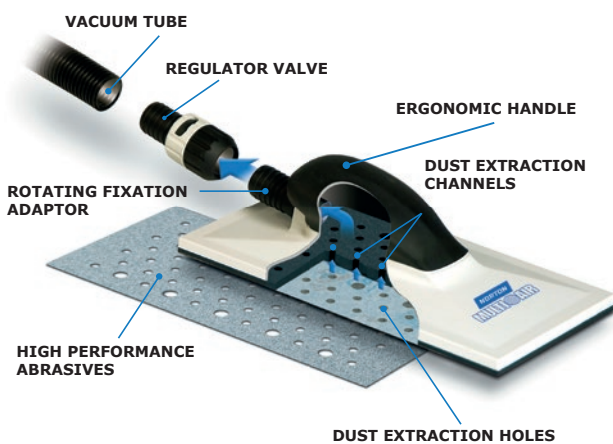

# CUT SHEETS

## PERFORATED SANDING BLOCK ACCESSORIES

	PK QTY	ART. NO.
Flexible 4 Metre Pipe	1	07660767979



## PERFORATED SANDING BLOCK KIT SELF-GRIP<sup>†</sup>

	PK QTY	ART. NO.
Sanding Block Kit	1	69957396649



<sup>†</sup> To help better describe the abrasive fixing system we have changed the name from 'NorGrip' to 'Self-Grip'.

COATED  
ABRASIVES  
& BEARTEX

BONDED  
ABRASIVES

SUPER  
ABRASIVES

DIAMOND  
TOOLS

CLEANING,  
POLISHING  
& MASKING

PERSONAL  
PROTECTION  
EQUIPMENT

TECHNICAL  
INFORMATION



# SELF-GRIP<sup>†</sup> PAPER ROLLS

Coated abrasive rolls are ideal for fast easy sanding of various materials. They can be torn to exact lengths as needed.

## APPLICATIONS & MARKETS

- Light deburring
- Removing rust & scale
- Sanding & polishing
- Bare wood sanding
- Hand sanding
- Machine sanding on eccentric sanders
- Paint & plaster sanding
- Floor sanding



COATED  
ABRASIVES  
& BEARTEX

BONDED  
ABRASIVES

SUPER  
ABRASIVES

DIAMOND  
TOOLS

CLEANING,  
POLISHING  
& MASKING

PERSONAL  
PROTECTION  
EQUIPMENT

TECHNICAL  
INFORMATION

## H231

BEST +++++



### FEATURES

- Very strong F-weight paper
- High performance aluminium oxide abrasive
- Open grain distribution
- Anti-static properties

### BENEFITS

- Ideal for sanding flat wooden or painted surfaces
- Suitable for metal surface finishing
- Reduces clogging
- Helps minimise dust when used with an appropriate extraction system

## NORTON PRO A275

BETTER ++++



**PRO**



### FEATURES

- Fibre-reinforced latex, B-weight paper
- Premium heat-treated aluminium oxide abrasive blend
- Water based No-Fil anti-loading third layer
- No pigments in No-Fil or bonding system

### BENEFITS

- Tear resistant
- Suitable for use on primer, paint filler & coating sanding (for automotive & transport applications)
- Long lasting, fast cut rate
- Good finish, used wet or dry
- Resists loading & extends life
- No risk of colour transfer

<sup>†</sup> To help better describe the abrasive fixing system we have changed the name from 'NorGrip' to 'Self-Grip'.

## SELF-GRIP<sup>+</sup> ROLLS



### NORTON PRO

DIM WxL	GRIT	PK QTY	H231	A275
			BEST	BETTER
115mmx25M	40	2	69957391121	
	60	2	69957391123	
	80	2	69957391133	
	120	2		69957391218
	150	2		69957391219
	180	2		69957391220
	220	2		69957391221
	240	2		69957391222
	320	2		69957391224
	400	2		69957391225

\* To help better describe the abrasive fixing system we have changed the name from 'NorGrip' to 'Self-Grip'.

## PRODUCT SELECTION GUIDE

MATERIALS / APPLICATIONS	HIGHLY RECOMMENDED	RECOMMENDED
Metal	H231	A275
Wood	H231	A275
Primer/Paint/Varnish	H231	A275

COATED  
ABRASIVES  
& BEARTEX

BONDED  
ABRASIVES

SUPER  
ABRASIVES

DIAMOND  
TOOLS

CLEANING,  
POLISHING  
& MASKING

PERSONAL  
PROTECTION  
EQUIPMENT

TECHNICAL  
INFORMATION





# BEARTEX ROLLS

## BEARTEX SLIT ROLLS

GOOD +++



### FEATURES

- High quality aluminium oxide or silicon carbide grain
- Uniform web construction
- Can be cut to exact sizes needed
- Flexible for hand and machine use
- Non-loading
- Non-rusting
- Resilient construction

### BENEFITS

- Long product life
- Controlled aggressiveness
- Economical; minimal waste
- Conforms to contours of work surface & provides a uniform finish
- Continual supply of new cutting edges
- No contamination of the workpiece
- Long life
- Waterproof & solvent resistant

DIM WxL	GRADE	CAP CODE	PK QTY	ART. NO.
100mmx10M	Medium A	F2300	2	63642557499
	Heavy Duty MED A	F2316	2	66261106168
	Fine A	F2401	2	66261018300
	Very Fine A	F2560	2	63642557738
	Very Fine A Long Life	F2504	2	66261018301
	Micro Fine A	F2801	2	63642557500
	Ultra Fine S	F4660	2	63642557501
115mmx10M	Very Fine A	F2560	2	63642557739
	Very Fine A Long Life	F2504	2	63642587694
	Ultra Fine S	F4660	2	63642557503
120mmx10M	General Purpose	F2568	2	63642515571
125mm x10M	Medium A	F2300	2	63642557504
	Fine A	F2401	2	66261018307
	Very Fine A	F2560	2	63642557740
	Very Fine A Long Life	F2504	2	66261018308
	Ultra Fine S	F4660	2	63642557506
150mmx10M	Medium A	F2300	2	63642557507
	Heavy Duty MED A	F2316	2	66261106011
	Very Fine A	F2504	2	66261018312

**Dimensions Key:** DIM = Dimensions, W = Width, L = Length

COATED ABRASIVES & BEARTEX

BONDED ABRASIVES

SUPER ABRASIVES

DIAMOND TOOLS

CLEANING, POLISHING & MASKING

PERSONAL PROTECTION EQUIPMENT

TECHNICAL INFORMATION

# BEARTEX ROTOLO ROLLS PRE-CUT

GOOD +++



### FEATURES

- Thinner web (Thinflex version)
- Ultra flexible
- Advanced web formation

### BENEFITS

- Cuts faster, saves time, with no added effort from the user. Product can be scrunched, rolled and saves shelf space
- Conforms better to contoured surfaces for an ultra consistent scratch pattern. Comfortable to use. Ideal for tight spaces
- Superior grain adhesion, durability and product life

### BEARTEX

DIM WxL	GRADE	CAP CODE	PK QTY	ART. NO.
115mmx10M	Very Fine A	F2504	1x1	77696009598
	Ultra Fine S	F4807	1x1	77696042071
	Gold	F2802	1x1	66261124481
	White	F0001	1x1	66261124480

### THINFLEX

DIM WxL	GRADE	CAP CODE	PK QTY	ART. NO.
115mmx10M	Very Fine A	F2543	1x1	77696042073
	Ultra Fine S	F4614	1x1	77696042075

**Dimensions Key:** DIM = Dimensions, W = Width, L = Length

COATED ABRASIVES & BEARTEX

BONDED ABRASIVES

SUPER ABRASIVES

DIAMOND TOOLS

CLEANING, POLISHING & MASKING

PERSONAL PROTECTION EQUIPMENT

TECHNICAL INFORMATION

# 209-228 HAND SANDING



210 Sheets & Hand Pads  
214 Beartex Sheets & Hand Pads

216 Abrasive Sponges  
218 Paper Rolls  
222 Cloth Rolls

224 Handy Rolls  
227 Rotolo Foam Rolls

COATED  
ABRASIVES  
& BEARTEX

BONDED  
ABRASIVES

SUPER  
ABRASIVES

DIAMOND  
TOOLS

CLEANING,  
POLISHING  
& MASKING

PERSONAL  
PROTECTION  
EQUIPMENT

TECHNICAL  
INFORMATION

# SHEETS & HAND PADS

Norton offers a wide range of paper, cloth & waterproof sheets for use in all commonly encountered industrial applications.

## APPLICATIONS & MARKETS

- Metal sanding
- Bare wood sanding
- Sanding between coats
- Scale & rust removal
- Scouring & light deburring



COATED  
ABRASIVES  
& BEARTEX

BONDED  
ABRASIVES

SUPER  
ABRASIVES

DIAMOND  
TOOLS

CLEANING,  
POLISHING  
& MASKING

PERSONAL  
PROTECTION  
EQUIPMENT

TECHNICAL  
INFORMATION

## BLACK ICE T401/T417

BEST +++++

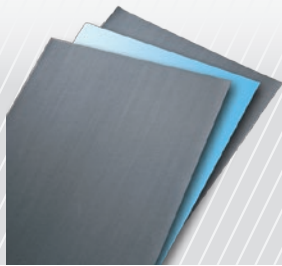

**BLACK  
ice**

### FEATURES

- Premium, ultra fine silicon carbide abrasive
- Advanced resin bond system
- Advanced, A-weight paper backing

### BENEFITS

- Best finish on wet clear-coat
- Waterproof
- Ultimate flexibility & waterproof performance

## T489

BETTER ++++



### FEATURES

- Silicon carbide abrasive
- Waterproof paper backing

### BENEFITS

- Advanced product
- Flexible

## NORTON PRO A275



**PRO**

### FEATURES

- Premium aluminium oxide grain
- Fibre-reinforced latex, B-weight paper
- No-Fil layer
- No pigments in No-Fil or bonding system

### BENEFITS

- Long lasting, fast cut rate
- Tear resistant
- Resists loading & extends life
- No risk of colour transfer



## R222



### FEATURES

- J-weight cloth backing
- Aluminium oxide abrasive

### BENEFITS

- Flexible product

## R202



### FEATURES

- Aluminium oxide abrasive
- Flexible J-weight cotton

### BENEFITS

- Polyvalent product

## A213



### FEATURES

- Aluminium oxide abrasive
- C-weight paper backing

### BENEFITS

- Aggressive cutting action for all dry sanding applications
- Heavy & light duty hand sanding

**GOOD +++**

## T221



### FEATURES

- Aluminium oxide abrasive
- Waterproof paper backing

### BENEFITS

- Multi-purpose product

COATED ABRASIVES & BEARTEX

BONDED ABRASIVES

SUPER ABRASIVES

DIAMOND TOOLS

CLEANING, POLISHING & MASKING

PERSONAL PROTECTION EQUIPMENT

TECHNICAL INFORMATION



## WATERPROOF SHEETS

### BLACK ICE

DIM WxL(mm)	GRIT	PK QTY	T401/T417	T489	T221
			BEST	BETTER	GOOD
230x280 	60	50		63642532956	
	80	50	66261021180	63642532988	
	100	50		63642532989	
	120	50	66261021183	63642532990	
	150	50		63642532991	
	180	50	66261021185	63642532957	63642536402
	220	50	66261021186	63642532992	63642536401
	240	50	66261021187	63642532993	63642536400
	280	50	66261021188	63642532994	63642536399
	320	50	66261021189	63642532995	63642535049
	360	50	66261021190	63642532996	63642534013
	400	50	66261021191	63642532997	63642536397
	500	50	66261021192	63642532998	63642536403
	600	50	66261021193	63642532999	63642536396
	800	50	66261021195	63642533000	63642536414
	1000	50	66261021196	63642533001	63642561379
	1200	50	66261021197	63642533002	63642536578
1500	50	63642534713			
2000	50	63642534719			
2500	50	63642565497			

## PAPER SHEETS

### NORTON PRO

DIM WxL(mm)	GRIT	PK QTY	A275	A213
			BETTER	GOOD
230x280 	40	25		63642536385
	60	50		63642536387
	80	50	63642558015	69957360388
	100	50	63642585256	
	100	100		69957360389
	120	100	63642558016	69957360390
	150	100	63642586145	69957360391
	180	100	63642558017	63642531774
	220	100	63642586139	63642536411
	240	100	63642558018	69957360394
	280	100	63642585742	
	320	100	63642586132	69957360396
	360	100	63642586133	
	400	100	63642586134	63642539112
	500	100	63642586136	
	600	100	63642586137	
	800	100	63642586138	



## CLOTH SHEETS

DIM WxL(mm)	GRIT SIZE	PK QTY	R222	R202
			BETTER	
230x280 	40	25	63642531776	69957360506
	50	25	63642531777	
	60	25	63642531778	63642536405
	80	50	63642531779	63642536407
	100	50	63642531780	63642536408
	120	50	63642531781	63642536410
	150	50	63642531782	63642536413
	180	50	63642531783	63642531773
	220	50	63642531785	63642563323
	240	50	63642531786	
	280	50	63642531788	
	320	50	63642531789	
	400	50	63642531790	
	600	50	63642534613	

**Dimensions Key:** DIM = Dimensions, W = Width, L = Length

## PRODUCT SELECTION GUIDE

MATERIALS / APPLICATIONS		HIGHLY RECOMMENDED	RECOMMENDED	SUITABLE
Metal		R222/T417/T402	R202/T489	
Wood	Paper		A275	A213
	Cloth	R222	R202	
Primer/Paint/Varnish	Wet Sanding - Waterproof	T417/T401	T489	T221
	Dry Sanding - No-Fil	A275		
MATERIALS / APPLICATIONS		DEBURRING	CLEANING	BLEND/FINISH
Metal		F2302	F2504	F4300/F4804
Wood		F2504		F4804
Primer/Paint/Varnish			F2504	F4807/F2802

COATED  
ABRASIVES  
& BEARTEX

BONDED  
ABRASIVES

SUPER  
ABRASIVES

DIAMOND  
TOOLS

CLEANING,  
POLISHING  
& MASKING

PERSONAL  
PROTECTION  
EQUIPMENT

TECHNICAL  
INFORMATION

# BEARTEX SHEETS & HAND PADS

Hand pads are ideal for a broad range of applications from cleaning and finishing to deburring and light polishing operations.

The flexibility of BearTex products ensures constant contact with the surface and prevents cutting or gauging when working.



COATED  
ABRASIVES  
& BEARTEX

BONDED  
ABRASIVES

SUPER  
ABRASIVES

DIAMOND  
TOOLS

CLEANING,  
POLISHING  
& MASKING

PERSONAL  
PROTECTION  
EQUIPMENT

TECHNICAL  
INFORMATION

## BEARTEX HAND PADS

GOOD +++

**BearTex**<sup>®</sup>



### FEATURES

- Flexible
- Gentle action
- Non-loading
- Non-rusting
- Resilient construction
- Easy to cut to desired size
- Perforated pads for clean and easy tearing also available



WEBSITE LINK

### BENEFITS

- Conforms to contours of work surface & provides a uniform finish
- Easily removes burrs without affecting the dimension of the workpiece
- Continual supply of new cutting edges
- No contamination of the workpiece
- Long life, waterproof & solvent resistant
- Can be folded to suit hand / shape
- Perforations allow for smooth, shred free split to create 2 smaller easy to use 115mm x 150mm pads

DIM WxH(mm)	GRADE	CAP CODE	PK QTY	PERFOR. HAND PADS (PRE-CUT)	HAND PADS
150x230	Extra Cut A	F2302	40**		63642557491
	Heavy Duty	F2316	20		63642577268
	Medium A	F2300	60**		63642557493
	Fine A	F2401	60*		66261018286
	Very Fine A Long Life	F2504	60*	66261018293	
		F2504	60*		66261018287
	Gen. Purpose Clean & Scour A	F2568	60*		63642574103
	Medium S	F4300	60**		66261039806
	Ultra Fine S	F4807	60*	66261018294	
		F4807	60**		77696046252
	Micro Fine A	F2801	60**		63642557277
White Cleaning (Non Abrasive)	F0001	60*		66261018283	
230x280	Very Fine A Long Life	F2504	35		66261018291
	Ultra Fine S	F4807	35		66261018292

\*Supplied in packs of 20 \*\*Supplied in packs of 10



## THIN FLEX HAND PADS

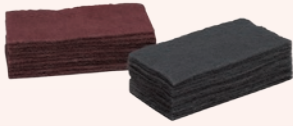

DIM WxH(mm)	GRADE	CAP CODE	PK QTY	ART. NO.
115x230	Very Fine A Long Life	F2543	4x25	63642506166
	Ultra Fine S	F4614	4x25	63642506167
	Micro Fine A	F2804	10x10	66261113519

**Dimensions Key:** DIM = Dimensions, W = Width, H = Height

## PRODUCT SELECTION GUIDE

CAP CODE	OLD REF	GRADE	MINERAL	TARGET SUBSTRATE	APPLICATION	FEATURES / BENEFITS
HAND PADS (IN ORDER OF DECREASING AGGRESSIVENESS)						
F2302	D305	Extra Cut	Aluminium Oxide	Stainless Steel	<ul style="list-style-type: none"> <li>Rust Removal</li> <li>Blending</li> <li>Deburring</li> <li>Bluing removal</li> </ul>	<ul style="list-style-type: none"> <li>Aggressive &amp; Durable</li> <li>Long life</li> <li>Ideal replacement for coated abrasive steel wool &amp; wire brushes</li> </ul>
F2300	D155	Medium	Aluminium Oxide	Metals & ceramics	<ul style="list-style-type: none"> <li>Cleaning, Deburring</li> <li>Rust removal</li> <li>Coating removal</li> </ul>	<ul style="list-style-type: none"> <li>Strong &amp; Open construction</li> <li>Resists loading</li> <li>Long life</li> <li>Ideal for achieving a matt satin finish</li> </ul>
F2401	D97	Fine	Aluminium Oxide	Wood & plastics	<ul style="list-style-type: none"> <li>Cleaning &amp; Intermediate finishing of ferrous &amp; non-ferrous metals</li> <li>Defuzzing wood, denibbing laquers, paints &amp; plastic</li> </ul>	<ul style="list-style-type: none"> <li>Coarser &amp; Stiffer than very fine</li> <li>Ideal for achieving a matt satin finish</li> </ul>
F2560/ F2529	D915	Very Fine	Aluminium Oxide	General Purpose	<ul style="list-style-type: none"> <li>Rust removal</li> <li>Automotive primer keying,</li> <li>Defuzzing wood, denibbing plastic</li> </ul>	<ul style="list-style-type: none"> <li>Conforms well to contoured surfaces</li> <li>Excellent finish on a wide variety of surfaces</li> </ul>
F2504	D28	Very Fine (Long Life)	Aluminium Oxide	General Purpose	<ul style="list-style-type: none"> <li>Rust removal</li> <li>Automotive primer keying,</li> <li>Defuzzing wood, denibbing plastic, light sanding of old paint and new primers</li> </ul>	<ul style="list-style-type: none"> <li>Moderate flexibility</li> <li>Fast initial cut</li> <li>Long life than standard products</li> <li>Gives no colour blend when used with solvents</li> </ul>
F2568	D63	Gen. purpose Clean & Scour	Alumina Silicate	Metals & Plastics	<ul style="list-style-type: none"> <li>General Purpose Cleaning, Surface preparation prior to painting</li> <li>Removal of light stains &amp; oxide marks on metal surfaces</li> </ul>	<ul style="list-style-type: none"> <li>Low cost pad</li> <li>Gives good performance at an economical price</li> </ul>
F4300	D125	Medium (SIC)	Silicon Carbide	Stainless Steel	<ul style="list-style-type: none"> <li>Satin finishing aluminium, cleaning glass moulds</li> <li>Grain finishing, removal of weld bluing on stainless steel</li> </ul>	<ul style="list-style-type: none"> <li>Resilient</li> <li>Conforms well to surface contours</li> </ul>
F4660/ F4807/ F4605	D985 (D26)	Ultra Fine	Silicon Carbide	General Purpose	<ul style="list-style-type: none"> <li>Keying clear coat, finishing metal, deburring plastics, finishing aluminium</li> <li>Doors &amp; window frames, blending paint, scuffing varnishes &amp; keying acrylic coatings</li> </ul>	<ul style="list-style-type: none"> <li>Can be used wet or dry with prepping compounds</li> </ul>
F2801/ F2829	D995	Micro Fine	Calcined Alumina	Precious Metals, Varnished Wood, Car Body Work	<ul style="list-style-type: none"> <li>Keying clear coat</li> <li>Polishing</li> </ul>	<ul style="list-style-type: none"> <li>Produces an extremely high quality surface finish</li> <li>Ideal for cleaning precious metals and finishing varnished wood</li> </ul>
F0001	D84	White Cleaning	None	All substrates	<ul style="list-style-type: none"> <li>Light cleaning, polishing,</li> <li>Rubbing down primer &amp; highlighting wood</li> </ul>	<ul style="list-style-type: none"> <li>Highly Conformable</li> <li>Tear resistant</li> <li>Ideal for use with liquid detergent</li> </ul>

COATED ABRASIVES & BEARTEX

BONDED ABRASIVES

SUPER ABRASIVES

DIAMOND TOOLS

CLEANING, POLISHING & MASKING

PERSONAL PROTECTION EQUIPMENT

TECHNICAL INFORMATION

# ABRASIVE SPONGES

Abrasive sanding sponges are designed for use on a wide variety of materials including wood, paint and metal. Their flexible nature means they can be used on curved, contoured and flat surfaces.

## APPLICATIONS & MARKETS

- Light stock removal
- Sanding contours & intricate shapes
- Finishing
- Removing minor defects
- Clear coat sanding
- Base coat sanding
- Scuffing primer
- Shaping filler

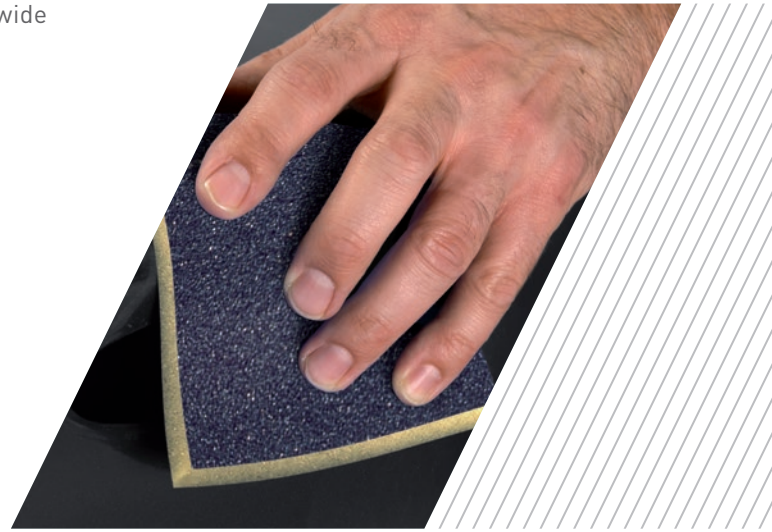

COATED  
ABRASIVES  
& BEARTEX

BONDED  
ABRASIVES

SUPER  
ABRASIVES

DIAMOND  
TOOLS

CLEANING,  
POLISHING  
& MASKING

PERSONAL  
PROTECTION  
EQUIPMENT

TECHNICAL  
INFORMATION

## SPONGES

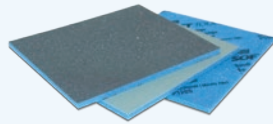

BETTER ++++

### FEATURES

- Multi-purpose
- Flexible
- Washable

### BENEFITS

- Can be used wet or dry
- Conform to surface shapes & contours, providing a uniform finish
- Can reach areas inaccessible to sandpaper sheets
- Can be reused, giving added product life

GRADE	GRIT	FINISH GENERATED*	APPLICATIONS	140 x 115 x 6mm	PK QTY
Medium	60	180/120	Scuffing, shaping filler	63642550599	20
Fine	100	400/320	Feather edging, scuffing primer, and new parts before painting	63642550601	20
Super Fine	180	600/500	Preparing panel for base coat	63642550602	20
Ultra Fine	220	1000/800	Sanding base coat, removing clear coat defects	63642550603	20
Micro Fine	280	1500/1200	Clear coat sanding, removing minor defects	63642550604	20

\* Generates a finer finish than conventional coated abrasive products





## SPONGES

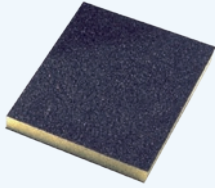

### FLEXIBLE FINISHING PADS 2 SIDED

DIM LxWxH(mm)	GRIT	PK QTY	ART. NO.
123x98x12,5	60	60	07660717578
	60	250	07660719341
	100	60	07660705187
	100	250	07660719342
	180	60	07660705188
	180	250	07660719343

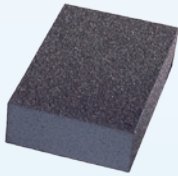

### FLEXIBLE SANDING SPONGES 4 SIDED

DIM LxWxH(mm)	GRIT	PK QTY	ART. NO.
100x66x26	60	60	07660717579
	100	60	07660705189
	100	250	07660719345
	180	60	07660705190
	180	250	07660719346

**Dimensions Key:** DIM = Dimensions, H = Height, W = Width, L = Length

## PRODUCT SELECTION GUIDE

MATERIALS	APPLICATIONS	HIGHLY RECOMMENDED
All workpiece materials	Rough	#60
	Semi-finishing	#100
	Finishing	#180

COATED  
ABRASIVES  
& BEARTEX

BONDED  
ABRASIVES

SUPER  
ABRASIVES

DIAMOND  
TOOLS

CLEANING,  
POLISHING  
& MASKING

PERSONAL  
PROTECTION  
EQUIPMENT

TECHNICAL  
INFORMATION

# PAPER ROLLS

Coated abrasive rolls are ideal for fast easy sanding of various materials. They can be torn to exact lengths as needed.

## APPLICATIONS & MARKETS

- Light deburring
- Removing rust & scale
- Sanding & polishing
- Bare wood sanding
- Hand sanding
- Machine sanding on eccentric sanders
- Paint & plaster sanding
- Floor sanding



COATED ABRASIVES & BEARTEX

BONDED ABRASIVES

SUPER ABRASIVES

DIAMOND TOOLS

CLEANING, POLISHING & MASKING

PERSONAL PROTECTION EQUIPMENT

TECHNICAL INFORMATION

## H231

BEST +++++



### FEATURES

- Very strong F-weight paper
- High performance aluminium oxide abrasive
- Open grain distribution
- Anti-static properties

### BENEFITS

- Ideal for sanding flat wooden or painted surfaces
- Suitable for metal surface finishing
- Reduces clogging
- Helps minimise dust when used with an appropriate extraction system

## NORTON PRO A275

BETTER ++++



**PRO**

### FEATURES

- Fibre-reinforced latex, B-weight paper
- Premium heat-treated aluminium oxide abrasive blend
- Water based No-Fil anti-loading third layer
- No pigments in No-Fil or bonding system

### BENEFITS

- Tear resistant
- Can be used wet
- Suitable for use on primer, paint filler & coating sanding (for automotive & transport applications) and wood
- Long lasting, fast cut rate
- Good finish
- Resists loading & extends life
- No risk of colour transfer



# G131F

**GOOD +++**



### FEATURES

- E-weight backing
- Aluminium oxide abrasive
- FSC mix certified paper backing

### BENEFITS

- Economy product for sanding wood, paint & plaster
- Good performance
- Responsibly sourced, environmentally friendly



COATED ABRASIVES & BEARTEX

BONDED ABRASIVES

SUPER ABRASIVES

DIAMOND TOOLS

CLEANING, POLISHING & MASKING

PERSONAL PROTECTION EQUIPMENT

TECHNICAL INFORMATION



### FSC CERTIFICATION

- Utilising responsibly sourced material and preserving natural resources is a high priority so our coated abrasive plants manufacturing paper backed products are now FSC certified.

## PAPER ROLLS

### NORTON PRO

DIM WxL	GRIT	PK QTY	NORTON PRO		
			H231 BEST	A275 BETTER	G131F GOOD
93mmx50m	80	2			66623372548
	100	2			66623372549
	120	2			66623372550
	150	2			66623372557
100mmx50m	40	2			66623372536
	60	2	69957361732		66623372537
	80	2	69957361771	63642591122	66623372538
	100	2	63642536968		66623372539
	120	2	63642537413	63642591123	66623372540
	150	2		69957391073	66623372555
	180	2		63642591124	
	220	2		63642590924	
	240	2		63642590927	
	320	2		63642591649	
400	2		69957391077		
115mmx25m	40	2			66623372572
	60	2			66623372573
	80	2			66623372574
115mmx50m	40	2			66623372551
	60	2			66623372204
	80	2		69957380739	66623372535
	100	2			66623372552
	120	2		69957380761	66623372545
	150	2		69957380765	66623372205
	180	2		69957380767	66623372558
	220	2		69957380769	66623372554
	240	2		69957380777	
	280	2		69957380778	
	320	2		69957380779	
400	2		69957380781		
500	2		69957396696		

COATED  
ABRASIVES  
& BEARTEX

BONDED  
ABRASIVES

SUPER  
ABRASIVES

DIAMOND  
TOOLS

CLEANING,  
POLISHING  
& MASKING

PERSONAL  
PROTECTION  
EQUIPMENT

TECHNICAL  
INFORMATION



**PAPER ROLLS (CONTINUED)**

DIM WxL	GRIT	PK QTY	NORTON PRO		
			H231 BEST	A275 BETTER	G131F GOOD
120mmx50m	40	1			66623372542
	60	1	63642539189		66623372543
	80	1	63642539187		66623372553
	100	1	63642539185		66623372541
	120	1	63642539183		66623372544
	150	1	63642539181		66623372556
	180	1	63642546049		66623372559
150mmx50m	60	1	63642546050		
	80	1	69957361785		
	100	1	63642546054		
	120	1	69957361838		
	150	1	63642546058		

**SELF-GRIP<sup>†</sup> ROLLS**



DIM WxL	GRIT	PK QTY	NORTON PRO	
			H231 BEST	A275 BETTER
115mmx25m	40	2	69957391121	
	60	2	69957391123	
	80	2	69957391133	
	120	2		69957391218
	150	2		69957391219
	180	2		69957391220
	220	2		69957391221
	240	2		69957391222
	320	2		69957391224
	400	2		69957391225

**Dimensions Key:** DIM = Dimensions, W = Width, L = Length

<sup>†</sup> To help better describe the abrasive fixing system we have changed the name from 'NorGrip' to 'Self-Grip'.

COATED  
ABRASIVES  
& BEARTEX

BONDED  
ABRASIVES

SUPER  
ABRASIVES

DIAMOND  
TOOLS

CLEANING,  
POLISHING  
& MASKING

PERSONAL  
PROTECTION  
EQUIPMENT

TECHNICAL  
INFORMATION



# CLOTH ROLLS

COATED ABRASIVES & BEARTEX

## R309

BEST +++++



### FEATURES

- Super flexible cotton cloth
- Premium aluminium oxide abrasive
- Semi-open grain distribution

### BENEFITS

- Ideal for contour & profile sanding
- Long life in wood & metal applications
- For reduced clogging in wood applications

BONDED ABRASIVES

## R222



### FEATURES

- J-weight cotton cloth
- Aluminium oxide abrasive

### BENEFITS

- Flexible product
- General purpose product for hand sanding of wood & metal

SUPER ABRASIVES

## R202

BETTER ++++



### FEATURES

- Flexible J-weight cotton
- Aluminium oxide abrasive

### BENEFITS

- Flexible & tear resistant
- Ideal for manual sanding

DIAMOND TOOLS

CLEANING, POLISHING & MASKING

## PRODUCT SELECTION GUIDE

MATERIALS / APPLICATIONS	HIGHLY RECOMMENDED	RECOMMENDED	SUITABLE
Metal	R309	R222	R212
Wood	H231	A275	
Primer/paint/varnish		A275	
MATERIALS / APPLICATIONS	DEBURRING	CLEANING	BLEND/FINISH
Metal	F2300	F2504/F2523	F4804
Wood	F2504		F4804
Primer/paint/varnish		F2504	F2801/F4804

PERSONAL PROTECTION EQUIPMENT

TECHNICAL INFORMATION



## CLOTH ROLLS

DIM WxL	GRIT	PK QTY	R309	R222	R202
			BEST		BETTER
50mmx50m	40	5		63642512909	
	60	5		63642540086	
	80	5		63642539135	
	100	5		63642539136	
	120	5		63642559727	
	150	5		63642539208	
	180	5		63642539137	
	220	5		63642512916	
	240	5		63642512917	
	320	5		63642512918	
	400	5		63642512919	
100mmx50m	40	1		63642536559	
	60	1	69957385334	63642560979	
	80	1	63642555261	63642531852	
	100	1	69957385335	63642531854	
	120	1	69957385336	63642531855	
	150	1	69957384617	63642545861	
	180	1	69957385337	63642531856	
	240	1		63642531857	
	320	1		63642545865	
	400	1		63642545867	
120mmx50m	40	1			63642582342
	60	1	69957385339		63642582343
	80	1	63642555659		63642582345
	100	1	69957385340		63642582346
	120	1	63642555601		63642582347
	150	1	69957385341		63642582348
	180	1	69957388153		63642582349
	240	1			66254473268
	320	1			66254473269
430mmx50m	50	1		63642539141	
	60	1		63642539142	
	80	1		63642539143	
	100	1		63642539144	
	120	1		63642539145	
	150	1		63642539146	
	180	1		63642539147	
	240	1		63642539148	

**Dimensions Key:** DIM = Dimensions, W = Width, L = Length

COATED  
ABRASIVES  
& BEARTEX

BONDED  
ABRASIVES

SUPER  
ABRASIVES

DIAMOND  
TOOLS

CLEANING,  
POLISHING  
& MASKING

PERSONAL  
PROTECTION  
EQUIPMENT

TECHNICAL  
INFORMATION

# HANDY ROLLS

COATED  
ABRASIVES  
& BEARTEX

BONDED  
ABRASIVES

SUPER  
ABRASIVES

DIAMOND  
TOOLS

CLEANING,  
POLISHING  
& MASKING

PERSONAL  
PROTECTION  
EQUIPMENT

TECHNICAL  
INFORMATION

## R222

BEST +++++



### FEATURES

- J-weight cloth backing
- Aluminium oxide abrasive
- Dispenser unit

### BENEFITS

- Ideal for sanding profiled surfaces & round steel parts
- Can be torn into strips
- For general purpose maintenance applications
- Ideal for deburring & derusting metal
- For easy storage
- Protects product
- Eliminates waste

## R202

BETTER ++++



### FEATURES

- Flexible J-weight cotton
- Aluminium oxide abrasive
- Dispenser unit

### BENEFITS

- Flexible & tear resistant
- For easy storage
- Protects product
- Eliminates waste



## F2316



### FEATURES

- Complementary finishing Handy Roll to R222 and R202 range
- Flexible and 3 dimensional conformability
- Premium aluminum oxide grain gives a performance boost
- Enhanced Clean Bond resin coverage
- Dispenser unit

### BENEFITS

- Durable blending and finishing roll
- Can access awkward corners and recesses
- Clean, blend, deburr and finish in record time
- Consistent uniform surface finish, no smearing
- For easy storage
- Protects product
- Eliminates waste

COATED  
ABRASIVES  
& BEARTEX

BONDED  
ABRASIVES

SUPER  
ABRASIVES

DIAMOND  
TOOLS

CLEANING,  
POLISHING  
& MASKING

PERSONAL  
PROTECTION  
EQUIPMENT

TECHNICAL  
INFORMATION

## PRODUCT SELECTION GUIDE

MATERIALS / APPLICATIONS	HIGHLY RECOMMENDED	RECOMMENDED
General purpose (metal, wood, etc.)	R222	R202







### SPEC CHECK

- R222 handy rolls are designed for manual applications. The high flexibility of the cloth in combination with the wide grit range, from coarse to fine, provides an excellent tool for a variety of applications including deburring, rust removal & finishing metal
- Handy rolls are packaged in a protective, convenient dispenser which eliminates costly waste & permits neat, easy storage



## HANDY ROLLS

DIM WxL	GRIT	PK QTY	R222	R202	F2316
			BEST	BETTER	
25mmx25m 	40	1	63642531849		
	50	1	63642531850		
	60	1	63642531823		
	80	1	63642531820		
	100	1	63642531815		
	120	1	63642531811		
	150	1	63642531808		
	180	1	63642531805		
	220	1	63642531802		
	240	1	63642531799		
	320	1	63642531796		
	400	1	63642531793		
	600	1	63642560206		
38mmx5m 	Heavy Duty MED A	1			66261129709
38mmx25m 	40	1	63642531828		
	50	1	63642531826		
	60	1	63642531824	63642549443	
	80	1	63642531821	63642549444	
	100	1	63642531817	63642549445	
	120	1	63642531812	63642549446	
	150	1	63642531809	63642549447	
	180	1	63642531806	63642549448	
	220	1	63642531803	63642549449	
	240	1	63642531800	63642549450	
	280	1	63642536425		
	320	1	63642531797	63642549451	
	400	1	63642531794	63642515260	
600	1	63642539150			
50mmx25m 	40	1	63642531829		
	50	1	63642531827		
	60	1	63642531825		
	80	1	63642534758		
	100	1	63642531818		
	120	1	63642531814		
	150	1	63642531810		
	180	1	63642531807		
	220	1	63642531804		
	240	1	63642531801		
	280	1	63642536426		
	320	1	63642531798		
	400	1	63642531795		
600	1	63642534757			

Dimensions Key: DIM = Dimensions, W = Width, L = Length





# ROTOLO FOAM ROLLS

## NORTON PRO A275

BETTER ++++



PAINT/VARN.  
HARD WOOD  
& SOFT WOOD

**PRO**

### FEATURES

- A275 Norton Pro premium abrasive paper
- Special No-Fil coating
- Flexible foam backing
- Water-resistant
- 25m long roll of pre-cut sheets
- Packed in innovative dispenser box

### BENEFITS

- Excellent for fine sanding with high finishing level
- Reduces clogging
- Ideal for use on round edges, contours & curves without breaking through the paint surface. Easy gripping
- Washable
- Easy to use & economical
- New Easy cut upgraded
- Easy to handle, protected against dust

## GOLD RESERVE A296

GOOD +++



FERR.  
& NON  
FERR.

PAINT/VARN.  
& HARD WOOD

**GOLD RESERVE**

### FEATURES

- "P" graded premium aluminium oxide grain
- Strong B weight latex/paper backing
- Water-based, non-loading stearate

### BENEFITS

- Produces a quick, cool cut
- Produces a more consistent scratch pattern
- Resists tearing
- Conformable and flexible
- Resists loading
- Increases productivity



### SPEC CHECK

- Rotolo Foam pre-cut sheets, conveniently packaged in a roll form, are ideal for fine sanding on round edges, contours & curves, providing an outstanding finish on primers & top coats. The secret of Rotolo Foam lies in the combination of Norton Pro A275 sanding paper & the special foam backing
- To ease product recognition, box labels are colour-coded to a specific grit size. The colour-coding follows the Norton Pro grit colour-coding system



COATED  
ABRASIVES  
& BEARTEX

BONDED  
ABRASIVES

SUPER  
ABRASIVES

DIAMOND  
TOOLS

CLEANING,  
POLISHING  
& MASKING

PERSONAL  
PROTECTION  
EQUIPMENT

TECHNICAL  
INFORMATION

## PRODUCT SELECTION

APPLICATION	GRIT	COLOUR
ROTOLO FOAM ROLLS A275		
Sanding of body filler	120	Apple Green
	150	Orange
	180	Purple
Sanding of finishing filler	220	Red
	240	Electric Blue
Sanding cataphoretic coats & primer	280	Grey
	320	Salmon
Sanding polyurethane primer	360	Pink
	400	Yellow
	500	Dark Blue
	600	Fuchsia
Cutting back lacquer before a flush joint	800	Turquoise
Retouching clear coat	1000	White
Before polishing & buffing	1500	Green

## ROTOLO FOAM ROLLS

DIM WxL	GRIT	COLOUR	PK QTY	NORTON PRO	GOLD RESERVE
				A275	A296
				BETTER	GOOD
115mmx25m 	120	Apple Green	2	63642535316	
	150	Orange	2	63642557584	
	180	Purple	2	63642557599	
	220	Red	2	63642557600	
	240	Electric Blue	2	63642557602	
	240	White	2		66261097596
	280	Grey	2	63642557604	
	280	White	2		66261097597
	320	Salmon	2	63642557606	
	320	White	2		66261097598
	360	Pink	2	63642557607	
	400	Yellow	2	63642557608	
	400	White	2		66261097599
	500	Dark Blue	2	63642557611	
	500	White	2		66261097600
	600	Fuchsia	2	63642557612	
	600	White	2		66261097601
	800	Turquoise	2	63642557613	
	800	White	2		66261097602
	1000	White	2	63642557616	
1500	Green	2	63642557617		

**Dimensions Key:** DIM = Dimensions, W = Width, L = Length

# 229-234 FILE BELT MACHINE



230 File Belts

233 Beartex Surface Blending File Belts

COATED ABRASIVES & BEARTEX

BONDED ABRASIVES

SUPER ABRASIVES

DIAMOND TOOLS

CLEANING, POLISHING & MASKING

PERSONAL PROTECTION EQUIPMENT

TECHNICAL INFORMATION

# FILE BELTS

Norton offers a range of file belts designed to perform on intricate shapes and contours.

## APPLICATIONS & MARKETS

- Light deburring & blending
- Spot repairs
- General clean-up & finishing



COATED  
ABRASIVES  
& BEARTEX

BONDED  
ABRASIVES

SUPER  
ABRASIVES

DIAMOND  
TOOLS

CLEANING,  
POLISHING  
& MASKING

PERSONAL  
PROTECTION  
EQUIPMENT

TECHNICAL  
INFORMATION

## VIKING R996



### FEATURES

- New generation SG ceramic grain
- New formulation of Supersize layer
- High performance resin system
- YY polyester backing for coarse grits (36-50)
- Available in grits 36, 40, 50, 60, 80

### BENEFITS

- Longer belt life
- High stock removal
- Advanced cooling system
- Less off hand pressure required to cut
- Reduced heat generation
- Maximum performance
- Fast and consistent cut rate
- Cost reduction per part

BEST +++++

INNOVATION

**VIKING**

## SG R929



### FEATURES

- X-weight polyester cloth
- Premium SG abrasive
- High content of active filler

### BENEFITS

- Extremely durable even on aggressive applications
- Excellent at low & medium pressure
- Cool cut
- Ideal for heat sensitive metals

BETTER ++++



## NORZON R822

*NorZon*



### FEATURES

- X-weight cotton cloth
- Norzon abrasive

### BENEFITS

- Stiff backing for backstand grinding
- Long lasting

## R265

**GOOD +++**



### FEATURES

- Heavy cotton cloth
- Premium aluminium oxide abrasive

### BENEFITS

- For semi-finishing operations
- Standard general purpose cloth for metal application

## FILE BELTS

DIM WxL(mm)	GRIT	PK QTY*	VIKING	SG	NORZON	R265
			R996	R929	R822	
			BEST INNOVATION	BETTER		GOOD
6x475	40	10	66261128500	66261123531	66261141212	66261141033
	60	10	66261128502	66261123532	66261141213	66261141034
	80	10	66261128503	66261123533	66261141214	66261141061
	120	10		66261123535	66261141215	66261141062
6x520	40	10	66261128505	66261123543	66261141216	66261141056
	60	10	66261128507	66261123545	66261141217	66261141057
	80	10	66261128508	66261123546	66261141219	66261141058
	120	10		66261123547	66261141220	66261141060
9x533	40	10	66261128510	66261123552	66261141223	66261141170
	60	10	66261128511	66261123553	66261141224	66261141171
	80	10	66261128512	66261123554	66261141226	66261141172
	120	10		66261123555	66261141228	66261141173
10x330	40	10		66623303110	66261144347	
	60	10		66261144369	66261144348	
	80	10		66623303270	66261144349	
	120	10		66623303271	66261144350	

\* Over Packaging = 100 pcs (10 pcs x 10 packs)

**Dimensions Key:** DIM = Dimensions, W = Width, L = Length

COATED  
ABRASIVES  
& BEARTEX

BONDED  
ABRASIVES

SUPER  
ABRASIVES

DIAMOND  
TOOLS

CLEANING,  
POLISHING  
& MASKING

PERSONAL  
PROTECTION  
EQUIPMENT

TECHNICAL  
INFORMATION



## FILE BELTS (CONTINUED)

DIM WxL(mm)	GRIT	PK QTY*	VIKING	SG	NORZON	
			R996	R929	R822	R265
			BEST INNOVATION	BETTER		GOOD
13x457	40	10	66261128495	66261123522	66261141253	66261141174
	60	10	66261128498	66261123523	66261141254	66261141175
	80	10	66261128499	66261123524	66261141255	66261141177
	120	10		66261123525	66261141256	66261141178
13x610	40	10	66261128518	66261123636	66261141257	66261141179
	60	10	66261128519	66261123638	66261141258	66261141180
	80	10	66261128520	66261123639	66261141260	66261141181
	120	10		66261123640	66261141261	66261141182
15x475	40	10	66261128521	66261123646	66261141262	66261141183
	60	10	66261128522	66261123647	66261141263	66261141184
	80	10	66261128523	66261123648	66261141264	66261141185
	120	10		66261123649	66261141265	66261141186
20x520	40	10	66261128514	66623303272	66261141266	66261141187
	60	10	66261128516	66261029755	66261141267	66261141188
	80	10	66261128517	66623303275	66261141269	66261141189
	120	10		66623303276	66261141270	66261141190

\* Over Packaging = 100 pcs (10 pcs x 10 packs)

COATED  
ABRASIVES  
& BEARTEX

BONDED  
ABRASIVES

SUPER  
ABRASIVES

DIAMOND  
TOOLS

CLEANING,  
POLISHING  
& MASKING

PERSONAL  
PROTECTION  
EQUIPMENT

TECHNICAL  
INFORMATION



**NEW** RAPIDPREP XF SURFACE BLENDING FILE BELTS

**GOOD +++**



**FEATURES**

- Durable fibre construction
- Very sharp abrasive grain
- Flexible backing
- Highly resistant to clogging & loading
- Various sizes available
- User friendly

**BENEFITS**

- Long lasting
- High, continuous cut rate
- Excellent performance on hard materials (steels, nickel, alloys etc.)
- Controlled cut
- Gives a consistent finish
- Ideal for belt file machines or backstand finishers
- Reduced risk of workpiece damage

DIM WxL	GRADE	CAP CODE	PK QTY	ART. NO.
6x457	Coarse	S2238	20	63642535959
	Medium	S2338	20	63642535963
	Fine	S2438	20	63642536140*
	Very Fine	S2538	20	66623333511
13x457	Coarse	S2238	20	63642535980
	Medium	S2338	20	63642536113
	Fine	S2438	20	63642536141*
	Very Fine	S2538	20	66261055311
19x457	Coarse	S2238	20	63642536114
	Medium	S2338	20	63642536116
	Fine	S2438	20	63642536142*
	Very Fine	S2538	20	66261003622
6x610	Coarse	S2238	20	63642536118
	Medium	S2338	20	63642536121
	Fine	S2438	20	63642536144*
	Very Fine	S2538	20	66623333512
13x610	Coarse	S2238	20	63642536122
	Medium	S2338	20	63642536129
	Fine	S2438	20	63642536145*
	Very Fine	S2538	20	66261019876
13x305	Coarse	S2238	20	63642536134
	Medium	S2338	20	63642536137
	Fine	S2438	20	63642536164*
	Very Fine	S2538	20	66254499884

More sizes available on a Made-to-order basis.

\* Made-to-order

**Dimensions Key:** DIM = Dimensions, W = Width, L = Length

COATED ABRASIVES & BEARTEX

BONDED ABRASIVES

SUPER ABRASIVES

DIAMOND TOOLS

CLEANING, POLISHING & MASKING

PERSONAL PROTECTION EQUIPMENT

TECHNICAL INFORMATION

## PRODUCT SELECTION GUIDE

MATERIALS / APPLICATIONS	HIGHLY RECOMMENDED	RECOMMENDED	SUITABLE
Stainless Steel/Heat Sensitive Alloys	R929		
Carbon Steel/Weld/Ferrous metal	R929		
Non-Ferrous Metal/Brass/Aluminium	R929		
Wood		R230	
Stone		R427	
Glass		R427	
MATERIALS / APPLICATIONS	DEBURRING	CLEANING	BLEND/FINISH
All metal	S2238	S2338	S2338



# 235-238 PORTABLE BELT SANDER



236 Portable Belts

COATED  
ABRASIVES  
& BEARTEX

BONDED  
ABRASIVES

SUPER  
ABRASIVES

DIAMOND  
TOOLS

CLEANING,  
POLISHING  
& MASKING

PERSONAL  
PROTECTION  
EQUIPMENT

TECHNICAL  
INFORMATION

# PORTABLE BELTS

Norton offers portable belts in a variety of sizes, designed to fit the most common types of machine. Portable belts are designed for all metal and wood working applications.

All Norton belts are supplied with butt joints for easy mounting and smoother work.

## APPLICATIONS & MARKETS

- Surface grinding & finishing of all metals
- Blending welds
- Sanding & finishing wood
- Floor sanding



COATED  
ABRASIVES  
& BEARTEX

BONDED  
ABRASIVES

SUPER  
ABRASIVES

DIAMOND  
TOOLS

CLEANING,  
POLISHING  
& MASKING

PERSONAL  
PROTECTION  
EQUIPMENT

TECHNICAL  
INFORMATION

## W445

BETTER ++++

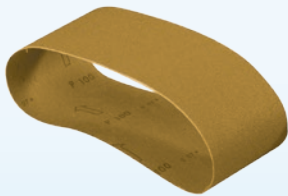

NON  
FERR.



GLASS  
ARISING

### FEATURES

- Polyester cloth
- Cork grain

### BENEFITS

- To be used wet or dry
- Ideal for final finishing of glass edges

## R427

GOOD +++



NON  
FERR.



STONE



GLASS  
ARISING

### FEATURES

- X-weight cotton cloth
- Silicon carbide abrasive

### BENEFITS

- Can be used for dry applications only
- Ideal for grinding glass & stone

## R230



NON  
FERR.



HARD WOOD  
& SOFT WOOD

### FEATURES

- Strong cloth backing
- Aluminium oxide abrasive
- Open grain distribution

### BENEFITS

- Multi-purpose product ideal for sanding wood & grinding metal
- Good cutting rate
- Reduced clogging on loading material such as wood & aluminium





## PORTABLE BELTS

R230

DIM  
WxL(mm)    GRIT    PK  
QTY

GOOD

75x457	40	10	63642538877
	60	10	63642539426
	80	10	63642539422
	120	10	63642539415
75x533	36	10	63642546461
	40	10	63642546289
	60	10	63642546257
	80	10	63642534248
	100	10	63642546273
	120	10	63642530701
75x610	40	10	63642546472*
	60	10	63642546473*
	80	10	63642567329*
	100	10	63642545869*
	120	10	63642546476*
100x560	40	10	63642546292
	60	10	63642546262
	80	10	63642546250
	100	10	63642549847
	120	10	63642546235
100x610	36	10	63642529801*
	40	10	63642546295
	50	10	63642546283
	60	10	63642560145
	80	10	63642529798
	100	10	63642546242
	120	10	63642529797
	150	10	63642539412
100x620	40	10	63642546457
	60	10	63642534465
	80	10	63642529799
	100	10	63642534770
	120	10	63642546452

\* Made-to-order

**Dimensions Key:** DIM = Dimensions, W = Width, L = Length

COATED  
ABRASIVES  
& BEARTEX

BONDED  
ABRASIVES

SUPER  
ABRASIVES

DIAMOND  
TOOLS

CLEANING,  
POLISHING  
& MASKING

PERSONAL  
PROTECTION  
EQUIPMENT

TECHNICAL  
INFORMATION

## PORTABLE BELTS (CONTINUED)

DIM WxL(mm)	GRIT	PK QTY	R230	
			GOOD	
110x620	40	10	63642530702*	
	50	10	63642546288	
	60	10	63642530700	
	80	10	63642530699	
	100	10	63642546245	
	120	10	63642546238	
100x690	40	10	63642537627	
	60	10	63642537544	
	80	10	63642537546	
	100	10	63642537548	
	120	10	63642537632	
100x915	40	20	63642545871*	
	60	10	63642545873	
	80	10	63642545875	
	120	10	63642534768	

\* Made-to-order

**Dimensions Key:** DIM = Dimensions, W = Width, L = Length

### PRODUCT SELECTION GUIDE

MATERIALS / APPLICATIONS	HIGHLY RECOMMENDED	RECOMMENDED	SUITABLE
Wood		R230	
Stone		R427	
Glass		W445/R427	
MATERIALS / APPLICATIONS	DEBURRING	CLEANING	BLEND/FINISH
All metal	S2216/S2211	S2316	S2516



#### SPEC CHECK

- All Norton belts are supplied with butt joints for easy mounting & smoother work.



# 239-250 BACKSTAND MACHINE



240 Narrow Belts for Metal

248 Narrow Belts for Wood

249 Surface Blending Belts

COATED  
ABRASIVES  
& BEARTEX

BONDED  
ABRASIVES

SUPER  
ABRASIVES

DIAMOND  
TOOLS

CLEANING,  
POLISHING  
& MASKING

PERSONAL  
PROTECTION  
EQUIPMENT

TECHNICAL  
INFORMATION

# NARROW BELTS FOR METAL

A wide selection of sizes and grits for most dimensioning, intermediate grinding and polishing applications.

## APPLICATIONS & MARKETS

- Grinding & deburring
- Heavy stock removal
- Blending, dimensioning & shaping
- Finishing
- Polishing



COATED  
ABRASIVES  
& BEARTEX

BONDED  
ABRASIVES

SUPER  
ABRASIVES

DIAMOND  
TOOLS

CLEANING,  
POLISHING  
& MASKING

PERSONAL  
PROTECTION  
EQUIPMENT

TECHNICAL  
INFORMATION

## VIKING R996



BEST +++++

INNOVATION

**VIKING**

### FEATURES

- New generation SG ceramic grain
- New formulation of Supersize layer
- High performance resin system
- YY polyester backing for coarse grits (36-50)
- Available in grits 36, 40, 50, 60, 80

### BENEFITS

- Longer belt life
- High stock removal
- Advanced cooling system
- Less off hand pressure required to cut
- Reduced heat generation
- Maximum performance
- Fast and consistent cut rate
- Cost reduction per part

## R976P



### FEATURES

- Backing: strong polyester cloth
- Abrasive: Ceramic Saint Gobain patented Grain
- Bond: high performance phenolic resin
- Third layer: a new high performance formulation of supersize
- Grit availability: 24 to 150
- Shape: Belts, Rolls
- New Bright Pink Color

### BENEFITS

- Higher material removal rate at low and medium pressure in fine grits
- Increased cut rate on Carbon and Stainless Steel material
- Low heat generation reduces risk of burn
- Excellent on various material types; from Stainless Steel to Inconel to Titanium
- Reduce your cost per part



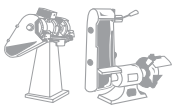

## SG R929



### FEATURES

- Polyester cloth
- Premium SG abrasive
- High content of active filler

### BENEFITS

- Stiff backing for demanding operations
- Excellent cut rate at low & medium pressure
- Cooler cut

## R946

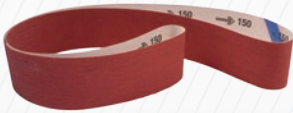

### FEATURES

- Optimised ratio of Hipal – SG ceramic grain
- Hipal technology with unique nano-microstructure & seeded gel technology for consistent grain sharpness
- Supersize layer
- High performance poly-cotton backing

### BENEFITS

- Efficient cut
- Excellent surface finish
- Fast and aggressive cut
- High stock removal
- Reduced process time
- Absorbs heat for a cooler cut and reduced work-piece burn
- Excellent tear resistance and flexibility, conforms to contours

## NORZON R822



### FEATURES

- X-weight cotton cloth
- Norzon abrasive

### BENEFITS

- Stiff backing for backstand grinding
- Long lasting

BETTER ++++

*NorZon*



## BLUE FORCE R872

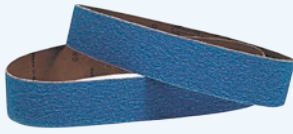

## FEATURES

- Optimized grain coverage
- Needle shape grain with engineered micro-fracturing properties
- Regeneration of cutting edges
- Y weight polyester backing
- Available in grits P24-P220



## BENEFITS

- Maximize efficiency
- Aggressive cutting action
- Longer belt life
- Higher stock removal
- Open structure to reduce loading
- Availability for every application
- Ideal for use on soft metals

## R426



## FEATURES

- Abrasive: silicon carbide
- Grit availability: P80 to P400
- Polycotton backing
- Shapes available: belts, rolls, jumbos

## BENEFITS

- Consistent cut rate
- Excellent surface finish
- Use for semi-finishing through to finishing applications
- Highly flexible and good tensile strength
- Easy to use flexible cloth backing

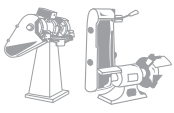

## R287 & R309

**GOOD +++**



### FEATURES

- Super flexible cotton cloth backing
- Aluminium Oxide abrasive

### BENEFITS

- Ideal for finishing operations on metal – Fine to Medium surface finish
- Excellent for sanding wood

## R293



### FEATURES

- Heavy polyester cloth
- Premium aluminium oxide
- Contains a small amount of SG abrasive
- Active filler

### BENEFITS

- Good performance
- Improved grain adhesion
- For use on metal & wood edgings
- For extended product life
- Improved life on metal applications

## R265



### FEATURES

- Heavy cotton cloth
- Premium aluminium oxide abrasive

### BENEFITS

- For semi-finishing operations
- Standard general purpose cloth for metal application

COATED  
ABRASIVES  
& BEARTEX

BONDED  
ABRASIVES

SUPER  
ABRASIVES

DIAMOND  
TOOLS

CLEANING,  
POLISHING  
& MASKING

PERSONAL  
PROTECTION  
EQUIPMENT

TECHNICAL  
INFORMATION

# NARROW BELTS FOR METAL

## CLOTH BELTS FOR METAL

DIM WxL(mm)	GRIT	PK QTY	VIKING	SG	SG	NORZON	
			R996	R976P	R929	R822	R293 & R265
			BEST INNOVATION			BETTER	GOOD
50x800	60	20			66261023832		
	80	20			66261023833		
	120	20			66261023834		
50x1500	60	10			66261023839		
	80	10			66261023840		
	120	10			66261023842*		
50x1600	36	10			66261023878*		
	40	10			66261023879		
	50	10			66261023880		
	60	10			66261023881		
	80	10			66261023882		
	120	10			66261023883*		
50x1750	36	10				63642546307*	63642547851*
	40	10				63642546308*	63642551487*
	50	10				63642539385*	63642551488*
	60	10				63642546310*	63642548467*
	80	10				63642546314*	
	100	10					63642539454**
50x2000	24	10		66261139040			
	36	10	66254403822	66261139041	69957350787	63642546222	63642546943
	40	10	66254403847	66261141661	69957350790	63642547270	63642551489
	50	10	66623316470*	66261141662	69957350792	63642546218*	
	60	10	66254411262	66261141663	69957350793	63642546210	63642546878
	80	10	66254449025	66261141664	69957350794	63642546212	63642539456**
	100	10		66261141665			
	120	10		66261141667	69957350795	63642516010	
50x2500	24	10		66261141670			
	36	10	66261099222	66261141671			63642540012*
	40	10	66254408229	66261141672			63642540013*
	50	10		66261141673			63642540014*
	60	10	66254416129	66261141674			63642540015*
	80	10	66254448015*	66261141675			63642547985*
	100	10		66261141676			
	120	10		66261141677			63642540016*
150	10		66261141678				

\* Made-to-order \*\* R265 product

COATED  
ABRASIVES  
& BEARTEX

BONDED  
ABRASIVES

SUPER  
ABRASIVES

DIAMOND  
TOOLS

CLEANING,  
POLISHING  
& MASKING

PERSONAL  
PROTECTION  
EQUIPMENT

TECHNICAL  
INFORMATION

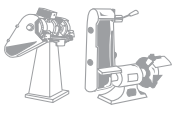

**CLOTH BELTS FOR METAL (CONTINUED)**

DIM WxL(mm)	GRIT	PK QTY	VIKING	SG	SG	NORZON	
			R996	R976P	R929	R822	R293 & R265
			BEST INNOVATION		BETTER		GOOD
50x3500	24	10		66261141680			
	36	10	66254404039	66261141681			
	40	10	66254404041	66261141682			
	50	10		66261141683			
	60	10	66254436885	66261141684			
	80	10	66254456931	66261141685			
	100	10		66261141686			
	120	10		66261141687			
50x4000	24	10		66261141689			
	36	10	66254404064	66261141032			
	40	10	66254404065	66261141691			
	50	10		66261141692			
	60	10	66254405015	66261141693			
	80	10	66254444896	66261141694			
	100	10		66261141695			
	120	10		66261141696			
75x2000	24	10		66261141698		63642539088	
	36	10	66254410065	66261141699	69957350796	63642539386	63642547942
	40	10	66254407955	66261141700	69957350797	63642539388	63642564728
	50	10		66261141701	69957350798	63642538998	63642548110
	60	10	66254407954	66261141702	69957350799	63642539389	63642548528
	80	10	66254456158	66261141703	69957350800	63642538999	63642548275
	100	10		66261141704	66261024222	63642539000*	
	120	10		66261141705	69957350801	63642539002	63642545882**
	150	10		66261141706			
	180	10					63642545883**
	240	10					63642520882**

\* Made-to-order \*\* R265 product

**Dimensions Key:** DIM = Dimensions, W = Width, L = Length

COATED  
ABRASIVES  
& BEARTEX

BONDED  
ABRASIVES

SUPER  
ABRASIVES

DIAMOND  
TOOLS

CLEANING,  
POLISHING  
& MASKING

PERSONAL  
PROTECTION  
EQUIPMENT

TECHNICAL  
INFORMATION

## CLOTH BELTS FOR METAL (CONTINUED)

DIM WxL(mm)	GRIT	PK QTY	VIKING	SG	SG	NORZON	
			R996	R976P	R929	R822	R293 & R230
			BEST INNOVATION			BETTER	GOOD
75x2250	36	10			66261023968		
	40	10			66261023969		
	50	10			66261023970		
	60	10			66261023971		
	80	10			66261023972		
75x2500	24	10		66261141707			
	36	10	66254403849	66261141708	69957350882	63642546092	63642546130
	40	10	66254403887	66261141709	69957350883	63642546094	63642546874
	50	10		66261141710	69957350884		
	60	10	66254403891	66261141711	69957350888	63642546097	63642551507
	80	10	66254469059*	66261141712	69957350898	63642546099	
	100	10		66261141713			
	120	10		66261141714	66261023977		
75x3000	36	10					63642551509*
	60	10					63642546202*
100x920	36	10				63642546226	63642551335*
	40	10				63642539330	63642548306
	50	10				63642539328	
	60	10				63642546216	63642548307
	80	10				63642546214	63642551544
	100	10				63642539383	63642551546
	120	10					63642551547
	180	10					63642551549
100x1000	40	10			69957350903	63642547284	66261032325**
	50	10				63642538971	
	60	10			69957350905	63642538973	63642551375
	60	10					66261032327**
	80	10			69957350906	63642538975	63642551553
	80	10					66261032328**
	100	10				63642538977	66261032323**
	120	10			69957350907	63642536388	66261032324**
100x1500	50	10			66261023978		
	80	10			66261023979		
	120	10			66261023980		
100x2000	36	10			69957350802		
	40	10			69957350804		
	60	10			69957350805		
	80	10			69957350806		
	120	10			69957350807		
	no grit	10			63642580818 (W448)		

\* Made-to-order \*\* R230 product



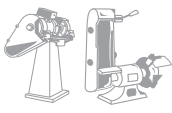

**CLOTH BELTS FOR METAL (CONTINUED)**

DIM WxL(mm)	GRIT	PK QTY	VIKING	SG	SG	NORZON	
			R996	R976P	R929	R822	R293 & R230
			BEST INNOVATION			BETTER	GOOD
120x1500	40	10				66261033858	66261032331**
	50	10				66261033859	66261032320**
	60	10				66261033860	66261032332**
	80	10				66261033861	66261032321**
	100	10				66261033862	66261032329**
	120	10				66261032232	66261032319**
150x2000	36	10			69957350809	63642539008	
	40	10			69957350812	63642539010	
	50	10			66261023983*		
	60	10			69957350813	63642539014	
	80	10			69957350815	63642539016	
150x2500	40	10			66261023984		
	50	10			66261023991*		
	60	10			66261023992		
	80	10			66261023993		
	120	10			66261023995*		

\* Made-to-order \*\* R230 product

**Dimensions Key:** DIM = Dimensions, W = Width, L = Length

COATED  
ABRASIVES  
& BEARTEX

BONDED  
ABRASIVES

SUPER  
ABRASIVES

DIAMOND  
TOOLS

CLEANING,  
POLISHING  
& MASKING

PERSONAL  
PROTECTION  
EQUIPMENT

TECHNICAL  
INFORMATION

# NARROW BELTS FOR WOOD

H231

BEST +++++



## FEATURES

- Very strong, F-weight paper
- High performance aluminium oxide abrasive
- Semi-open/open grain distribution
- Anti-static properties

## BENEFITS

- High performance & easy to mount
- Ideal for roughing, intermediate sanding & finishing
- Finer grits are ideal for polishing metal & plastic
- Resists clogging
- Excellent surface quality
- Less dust generated for an improved working environment

## PAPER BELTS FOR WOOD

DIM WxL(mm)	GRIT	PK QTY	ART. NO.
120x7000	60	10	63642539496*
	80	10	63642539497*
	100	10	63642539498*
	120	10	63642539499*
120x7100	60	10	63642539500
	80	10	63642539501
	100	10	63642539502
	120	10	63642539503
120x7200	60	10	63642539543*
	80	10	63642539544*
	100	10	63642539545*
	120	10	63642539546*
120x8000	60	10	63642539568
	80	10	63642539567
	100	10	63642539566
	120	10	63642539565

\* Made-to-order

COATED  
ABRASIVES  
& BEARTEX

BONDED  
ABRASIVES

SUPER  
ABRASIVES

DIAMOND  
TOOLS

CLEANING,  
POLISHING  
& MASKING

PERSONAL  
PROTECTION  
EQUIPMENT

TECHNICAL  
INFORMATION

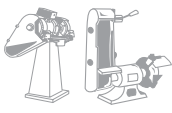

# SURFACE BLENDING BELTS

## NEW RAPIDPREP RF SURFACE BLENDING NARROW BELTS

GOOD +++



### FEATURES

- Durable fibre construction
- Very sharp abrasive grain
- Rigid, low stretch backing
- Highly resistant to clogging & loading
- Various sizes available
- User friendly

### BENEFITS

- Long lasting
- High, continuous cut rate
- Excellent performance on hard materials (steels, nickel, alloys etc.)
- Controlled cut
- Gives a consistent finish
- Ideal for belt file machines or backstand liners
- Reduced risk of workpiece damage

DIM WxL	GRADE	CAP CODE	PK QTY	ART. NO.
50x2000	Coarse	S2228	5	63642531724
	Medium	S2328	5	63642531726
	Fine	S2428	5	63642531732
	Very Fine	S2528	5	63642531733
75x2000	Coarse	S2228	5	63642531735
	Medium	S2328	5	63642531741
	Fine	S2428	5	63642531743
	Very Fine	S2528	5	63642531751
100x3500	Coarse	S2228	5	63642531760
	Medium	S2328	5	63642531761
	Fine	S2428	5	63642531764
	Very Fine	S2528	5	63642531784
150x2000	Coarse	S2228	5	63642531787
	Medium	S2328	5	63642531813
	Fine	S2428	5	63642531816
	Very Fine	S2528	5	63642531819

More sizes available on a Made-to-order basis.

**Dimensions Key:** DIM = Dimensions, W = Width, L = Length

COATED  
ABRASIVES  
& BEARTEX

BONDED  
ABRASIVES

SUPER  
ABRASIVES

DIAMOND  
TOOLS

CLEANING,  
POLISHING  
& MASKING



PERSONAL  
PROTECTION  
EQUIPMENT

TECHNICAL  
INFORMATION

## PRODUCT SELECTION

GRADE	FEATURES & BENEFITS
WHICH GRIT SHOULD I CHOOSE?	
Extra Coarse	Provides longest cutting life & highest aggressiveness to quickly achieve an even surface ready for finer finishing Ideal for descaling & removing heavy rust & oxides, Ideal for deburring, aluminium & excellent performance on hard materials
Coarse	Ideal where a less coarse finish or increased flexibility is required & an aggressive cut is necessary Removes 60-120 grit grindlines - for light deburring
Medium	Removes 120-180 grit grindlines - for cleaning & rust removal
Very Fine	Provides an excellent & uniform finish, ideal choice for fine finishing & pre-coat finishing Removes 180-320 grit grindlines - for finishing, polishing & paint preparation
Super Fine	The finest & most flexible surface conditioning for decorative finishes & excellent surfaces on soft & hard metals, ideal for pre-polishing

## RAPIDPREP BELT RANGE OVERVIEW

TYPE	OPERATION
<p><b>Rapid Prep RPA0-RF:</b> Refining and finishing all metals, where heavy duty combined with flexibility is needed: manual &amp; robotic operations. NARROW and WIDE BELT APPLICATIONS</p>	 <p>NARROW BELT For use on Back stand, bench stand and portable machines</p>
<p><b>Rapid Prep RPA0-XF:</b> Refining and finish all metals where most flexibility is needed: very flexible. FILE BELT APPLICATIONS</p>	 <p>FILE BELT For use on Dynaflex machines and other file belt sanders</p>

## PRODUCT SELECTION GUIDE

MATERIALS / APPLICATIONS		HIGHLY RECOMMENDED	RECOMMENDED	SUITABLE
Stainless Steel/Heat Sensitive Alloys	Stock Removal	R996*	R976*	R929
	Finishing	NORaX*		
Carbon Steel/Weld/Ferrous metal		R929	R822	R293/R265
Non-Ferrous Metal/Brass/Aluminium		R929	R822	R293/R265
Wood			H231/R309	
MATERIALS / APPLICATIONS		DEBURRING	CLEANING	BLEND/FINISH
All metal		RF S2228	RF S2328	RF S2528

\* Made-to-order

# 251-264 BENCH/PEDESTAL GRINDER



- 252 Flange Mounted Flap Wheels
- 254 Beartex Flange Mounted Flap Wheels

- 257 Rapid Finish Convolute Wheels

- 262 Convolute Wheels
- 264 High Strength Discs

COATED ABRASIVES & BEARTEX

BONDED ABRASIVES

SUPER ABRASIVES

DIAMOND TOOLS

CLEANING, POLISHING & MASKING

PERSONAL PROTECTION EQUIPMENT

TECHNICAL INFORMATION



# FLANGE MOUNTED FLAP WHEELS

Flange-mounted flap wheels have a continual rate of wear exposing new abrasive grain. Their design makes them ideal for sanding contours and uneven surfaces while delivering a consistent finish with a uniform rate of cut, especially on aluminum and stainless steel parts.

Flap wheels are conformable to intricate shapes and contours. The product structure, abrasive flaps anchored by a resin core at the centre, provides higher flexibility and very smooth surface finish.

Flange mounted flap wheels achieve their best performance at a recommended speed of 38-42m/s. At this speed, abrasive flaps stand up straight due to centrifugal force and only the edges are in contact with the workpiece, optimizing stock removal, surface finish, thermal load of the workpiece and toll wear.

**APPLICATIONS & MARKETS:** Flap wheels are an ideal choice for a wide variety of blending, deburring, finishing applications common in the metal fabrication, welding and polishing industries.

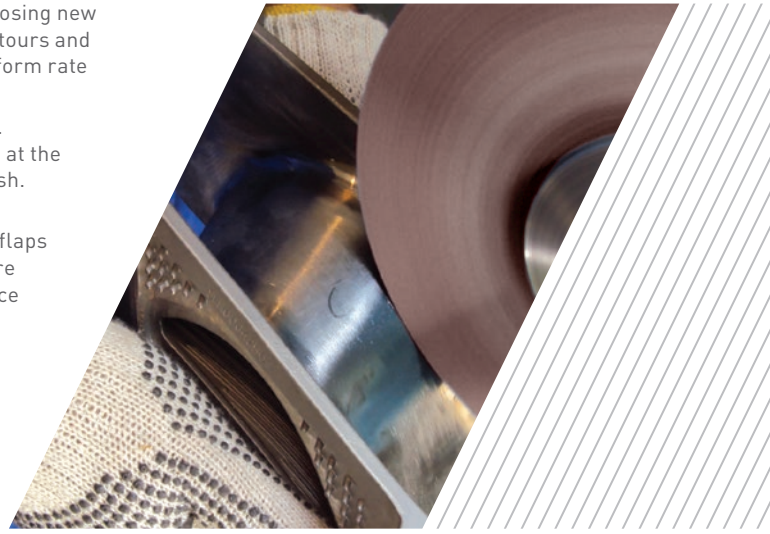

COATED  
ABRASIVES  
& BEARTEX

BONDED  
ABRASIVES

SUPER  
ABRASIVES

DIAMOND  
TOOLS

CLEANING,  
POLISHING  
& MASKING

PERSONAL  
PROTECTION  
EQUIPMENT

TECHNICAL  
INFORMATION

GOOD +++

**BDX** R207

FLANGE MOUNTED FLAP WHEELS

**BDX**



The GOOD choice where superior finish is required or on low-pressure applications. Universal product for steel, stainless steel but also for paint removal, plastic or wood.

**FEATURES**

- Premium aluminum oxide grain
- Flexible cotton backing

**BENEFITS**

- For aggressive cut and longer life
- Excellent cut rate with ability to leave a very good finish
- Conformable to the workpiece

DIM DIAxWxB (mm)	GRIT							RECOMMEND SPEED (RPM)	PK QTY
	P40	P60	P80	P120	P180	P240	P320		
100x25x25	63642547168	66261140370	63642574115	66261140372				7300 - 8000	2
100x50x25	66261140373	66261140375	66261140376	66261140377				7300 - 8000	1
150x25x25	66623317452	63642563719	63642546728	63642546740	63642546749	77696046364		4800 - 5400	2
150x50x25	66261140555	63642546712	63642546729	66261140556	66261140558	63642545892		4800 - 5400	1
165x25x32	63642547170	63642546711	63642546730	63642546742	66261140560	66261140606	66261140607	4300 - 4900	2
165x50x32	66261140608	63642561961	63642546731	63642546743	63642546751	66261140610	63642545894	4300 - 4900	1
200x25x35		63642547173	63642547175	66261140611	63642512956	63642546720	66261140612	3600 - 4000	1
200x50x35		66261140613	63642546732	66261140614	66261140615	66261140616	63642500895	3600 - 4000	1
250x50x35		66261140617	63642546733	63642546745	66261140618	66261140619	66261140620	2900 - 3200	1

Other sizes available upon request.

Alternative Bore Hole sizes upon request - please also see Accessories section for reduction bushings.



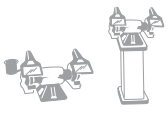

### FLANGE MOUNTED MAXIMUM OPERATING SPEED

DIA(mm)	MAX RPM
100	8000
150	5800
165	5500
200	4500
250	3500
300	2800
350	2500
400	2200

**Dimensions Key:** DIM = Dimensions, DIA = Diameter, W = Width, B = Bore



### SPEC CHECK

To prevent unnecessary tool wear do not increase the contact pressure too much, the increase of stock removal should be achieved by using a coarser grit size.

To get a slightly finer surface increase the cutting speed.

To get a slightly rougher finishing increase the contact pressure.

Using same grit size, the finishing is rougher on softer materials.

COATED  
ABRASIVES  
& BEARTEX

BONDED  
ABRASIVES

SUPER  
ABRASIVES

DIAMOND  
TOOLS

CLEANING,  
POLISHING  
& MASKING

PERSONAL  
PROTECTION  
EQUIPMENT

TECHNICAL  
INFORMATION

# BEARTEX FLANGE MOUNTED FLAP WHEELS

Formed by mounting sheets of Beartex around a centre core. The tight packed piece forms the spokes of a wheel. This construction makes flap wheels the most conformable of all Beartex Wheel products... providing a cushioning action which is ideal for use on uneven or irregular surfaces, as well as flat areas.

## APPLICATIONS & MARKETS

- Cleaning threaded parts
- Removing oxide from printed circuit boards
- De-glossing plastic parts
- Producing uniform finishes on aluminium, brass & stainless steel
- Can be used on automatic & robotic equipment



## BEARTEX FLAP WHEEL TYPES

2 types of flap wheel are available:

- 1) 100% non-woven flap wheels (standard for stock)
- 2) Interleaved flap wheels (made-to-order)

Both in variable sizes with widths from 10 to 2000mm.

Available in a wide range of abrasive types, grits and densities for metal and woodworking.

### Interleaved flap wheels

Interleaved version gives the benefits of aggressiveness by alternatively arranging coated abrasive cloth with the finishing qualities of non wovens. They are soft and aggressive, creating a "firmer" wheel that provides a higher rate of cut. The ratio of Cloth flaps to non-woven flaps can be altered to suit particular applications.

Ideal for deburring and grain finishing on stainless steel. Available in both spindle and flange mounted versions. Flange mounted interleaved wheels can be shaped to match the profile, e.g: a wood moulding.

### Densities

The different densities facilitate a versatility ranging from soft cushioning pads to hard cleaning and finishing tools. The density of a wheel can be increased (hardened) by adding more flaps, as shown below:

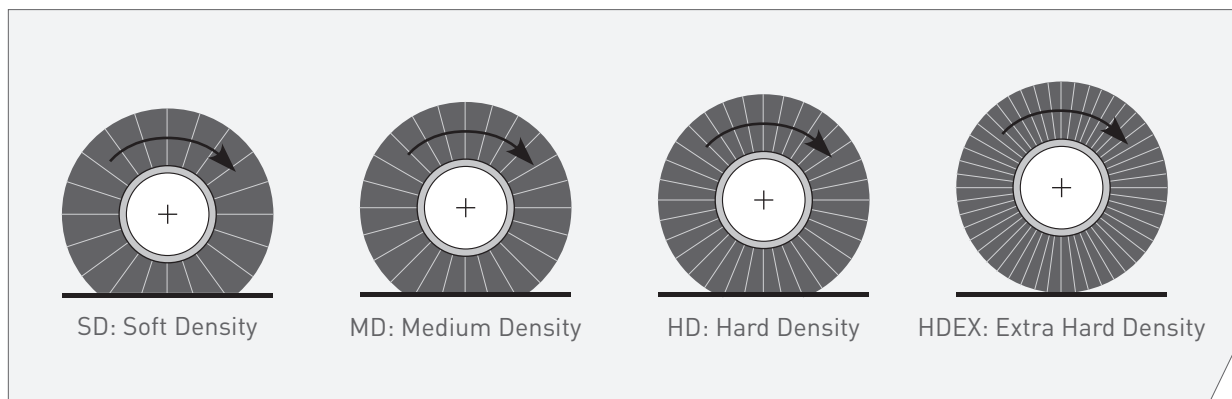

SD: Soft Density

MD: Medium Density

HD: Hard Density

HDEX: Extra Hard Density

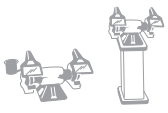

## FLAP WHEELS

GOOD +++

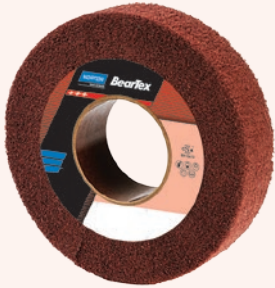

**BearTex**®

### FEATURES

- Cushioning action
- Constructed using layers of BearTex with a smear resistant formula
- Available in a wide range of sizes & grades
- Ventilated flap arrangement

### BENEFITS

- The most conformable of all BearTex wheel products. Ideal for use on contoured surfaces & parts with awkward geometry
- Achieves a consistent & uniform finish with no risk of gouging
- Suitable for a wide range of applications including corrosion removal, cleaning & surface finishing
- Smooth running vibration free product that gives a constant finish without smearing or component discolouration

### BEARTEX FLANGE MOUNTED FLAP WHEELS - MEDIUM DENSITY

DIM DxWxB(mm)	GRADE	CAP CODE	PK QTY	ART. NO.
150x50x50	Coarse A	F2212	1	66261083026
	Med A	F2312	1	66261082061
	Med A Heavy Duty	F2316	1	66261083074
	Fine A	F2412	1	66261083078
	Very Fine A	F2519	1	66261083082*
	Ultra Fine S	F4612	1	66261083084*
200x50x76	Coarse A	F2212	1	66261083027
	Medium A	F2301	1	63642588131
	Med A Heavy Duty	F2316	1	66261083075
	Fine A	F2412	1	66261083079
	Very Fine A	F2504	1	63642588137
	Very Fine S	F4501	1	63642588145

\* Made-to-order

More sizes available on a Made-to-order basis.

**Dimensions Key:** DIM = Dimensions, D = Diameter, W = Width, B = Bore

Refer to accessories section at the back of this catalogue for information on metal bushings. The catalogue includes details of all stock products but other options are available in various sizes, grades & densities using Norton's made to order facility. Please contact your local sales or customer service representative for more information.

COATED  
ABRASIVES  
& BEARTEX

BONDED  
ABRASIVES

SUPER  
ABRASIVES

DIAMOND  
TOOLS

CLEANING,  
POLISHING  
& MASKING

PERSONAL  
PROTECTION  
EQUIPMENT

TECHNICAL  
INFORMATION

# FLANGE MOUNTED FLAP WHEELS

## BEARTEX FLAP WHEEL APPLICATION GUIDE

SGA MCC	GRADE	MD	OLD QUALITY NAME	GRAIN TYPE	APPLICATION
F2212	Coarse A	DAB01	-	Aluminium Oxide	<ul style="list-style-type: none"> <li>Aggressive, very durable, cutting capacity constant</li> <li>Removal of material and corrosion.</li> </ul>
F2301 / F2312	Medium A	D0005	D05/DIS	Aluminium Oxide	<ul style="list-style-type: none"> <li>Specially made for Stainless steel and Aluminium.</li> <li>Matt satin finish</li> </ul>
F2305	Medium A Heavy Duty	-	-	Aluminium Oxide	<ul style="list-style-type: none"> <li>Faster working and coarser finish than F2301</li> <li>Higher durability with ability to withstand sharp edges</li> <li>Specially engineered to avoid smearing.</li> </ul>
F2401 / F2412	Fine A	D0097	D97	Aluminium Oxide	<ul style="list-style-type: none"> <li>Fine matt satin finish on stainless steel</li> <li>Defuzzing wood, scuffing paints and varnishes</li> </ul>
F2402	Fine A	D0002	D02	Aluminium Oxide	<ul style="list-style-type: none"> <li>Use for all metals.</li> <li>Contains special anti-smearing resin</li> </ul>
F2501 / F2519	Very Fine A	D0091	D91	Aluminium Oxide	<ul style="list-style-type: none"> <li>Finishing all metals</li> <li>Cleaning and removing oxide on soft metals.</li> </ul>
F4301	Medium S	D0054	D54	Silicon Carbide	<ul style="list-style-type: none"> <li>Semi bright satin finish on stainless steel</li> <li>Surface preparation on aluminium before anodising</li> </ul>
F4401	Fine S	D0071	D71	Silicon Carbide	<ul style="list-style-type: none"> <li>Special stainless steel, aluminium and brass</li> <li>Weld surface preparation</li> <li>Wood - sanding of primer - scuffing paints and varnishes.</li> </ul>
F4501	Very Fine S	D0089	D89	Silicon Carbide	<ul style="list-style-type: none"> <li>Semi bright satin finish on aluminium, brass and precious metals.</li> <li>Wood - uniform finish - scuffing varnishes</li> </ul>
F4601 / F4612	Ultra Fine S	D0098	D98	Silicon Carbide	<ul style="list-style-type: none"> <li>Light cleaning on metals</li> <li>Light finishing on precious metals, scuffing varnishes.</li> </ul>
F4801	Micro Fine S	D0075	D75	Silicon Carbide	<ul style="list-style-type: none"> <li>Super finishing</li> </ul>

COATED ABRASIVES & BEARTEX

BONDED ABRASIVES

SUPER ABRASIVES

DIAMOND TOOLS

CLEANING, POLISHING & MASKING

PERSONAL PROTECTION EQUIPMENT

TECHNICAL INFORMATION



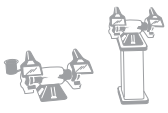

# RAPID FINISH CONVOLUTE WHEELS

Convolute wheels are formed by wrapping non-woven web material around a center core and bonding the layers together to create an abrasive wheel. These wheels are available in various diameters, grades and densities.

## APPLICATIONS & MARKETS

- Burr & flash removal
- Reducing surface roughness
- Blending welds on stainless steel
- Blending scratch patterns
- Weld polishing
- Removing rust & oxides
- Applying decorative finishes



COATED  
ABRASIVES  
& BEARTEX

BONDED  
ABRASIVES

SUPER  
ABRASIVES

DIAMOND  
TOOLS

CLEANING,  
POLISHING  
& MASKING

PERSONAL  
PROTECTION  
EQUIPMENT

TECHNICAL  
INFORMATION

## VORTEX CONVOLUTE

BETTER ++++



**VORTEX**  
RAPID FINISH

The Most Aggressive, Form-Holding Convolute Wheels.

The breakthrough technology in our proprietary Vortex engineered grain and bond gives these new Vortex convolute wheels up to 2x the cut rate and 5x the life of conventional convolute wheels, making them the first choice for deburring and finishing applications, such as:

- Deburring and finishing automotive gears
- Imparting decorative finishes on plumbing fixtures
- Blending and finishing turbine engine components
- Metal finishing and weld blending at fabrication shops
- Alternative to set-up wheels

### FEATURES

- Unequaled, proprietary Vortex aluminum oxide engineered grain and resin bond system
- Advanced, porous web structure and design

### BENEFITS

- Aggressive, fast-cutting stock removal with exceptional form-holding and uniform finish
- Up to 2x the cut rate and 5x the life of competitive convolute wheels
- Reduced cycle times
- Less truing
- Cooler cutting and improved cut rate
- Minimal wheel wear (“shedding”)

All Vortex convolute wheels are made-to-order.

## NEW BEARTEX NON-WOVEN WEBSITE

Scan the QR code or visit website using the web address below.

[www.nortonbeartex.com](http://www.nortonbeartex.com)



WEBSITE LINK

# RAPID FINISH CONVOLUTE WHEELS

GOOD +++

## RAPID FINISH DCS

Fine finish with light pressure



### FEATURES

- Open mesh construction
- Silicon carbide grain
- Softest convolute wheel

### BENEFITS

- Good for blending, rust removal, applying decorative contrast finishes and low to moderate speed applications
- Not used for deburring

**RAPID FINISH™**

## RAPID FINISH DSS SURFACE FINISHING

Uniform finish with moderate pressure



### FEATURES

- Stronger web compared to clean/finish wheels

### BENEFITS

- More aggressive cutting action & more durability than clean/finish wheels
- Ideal for rust & paint removal, coarse decorative finishes & blending

## RAPID FINISH DMA RED METAL FINISHING

Light deburring, blending & final finishing



### FEATURES

- Strongest resin binders
- Dense, very durable web
- Premium, medium grit aluminium oxide grain
- Uniform grain dispersion & coating

### BENEFITS

- Resilient long life construction
- Can be used for light deburring
- Generates uniform distinct satin & antique finishes
- Cleans & conditions without gouging or changing dimensions of workpiece

COATED  
ABRASIVES  
& BEARTEX

BONDED  
ABRASIVES

SUPER  
ABRASIVES

DIAMOND  
TOOLS

CLEANING,  
POLISHING  
& MASKING

PERSONAL  
PROTECTION  
EQUIPMENT

TECHNICAL  
INFORMATION

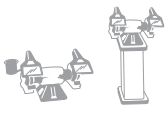

## RAPID FINISH LIGHT FINISHING

Light deburring, blending & final finishing



### FEATURES

- Ideal for deburring parts with tight tolerances, without altering geometry
- Improved conformability and resiliency deliver optimum workability to effectively polish intricate profiles in minimal time

### BENEFITS

- Light deburring and finishing of turbine engine and aerospace components
- Finishing applications demanding superior quality and high consistency

## RAPID FINISH SERIES 1000 LONG LIFE

General deburring, blending & finishing



### FEATURES

- Improved smear & heat resistant formula
- Waterproof non-metallic
- Dense web construction (9 density)
- More open web construction (6 density)

### BENEFITS

- Use dry, wet or with oil
- No contamination of workpiece
- Long life & consistent high quality results
- Starting point for deburring, blending, polishing & finishing
- Smear proof & cool cutting on light deburring applications

## RAPID FINISH SERIES 4000

Ideal for heavy deburring applications



### FEATURES

- Improved resin bond system
- High quality synthetic web
- Smear & heat resistant
- Premium abrasive grain
- Waterproof

### BENEFITS

- Free cutting – use both wet & dry
- More consistent finish. Better performance
- Long life for heavy deburring, edge breaking & removing parting lines on exotic metals
- The choice for when edge & form holding are of primary importance

COATED  
ABRASIVES  
& BEARTEX

BONDED  
ABRASIVES

SUPER  
ABRASIVES

DIAMOND  
TOOLS

CLEANING,  
POLISHING  
& MASKING

PERSONAL  
PROTECTION  
EQUIPMENT

TECHNICAL  
INFORMATION

## CONVOLUTE WHEEL NAMING SCHEME

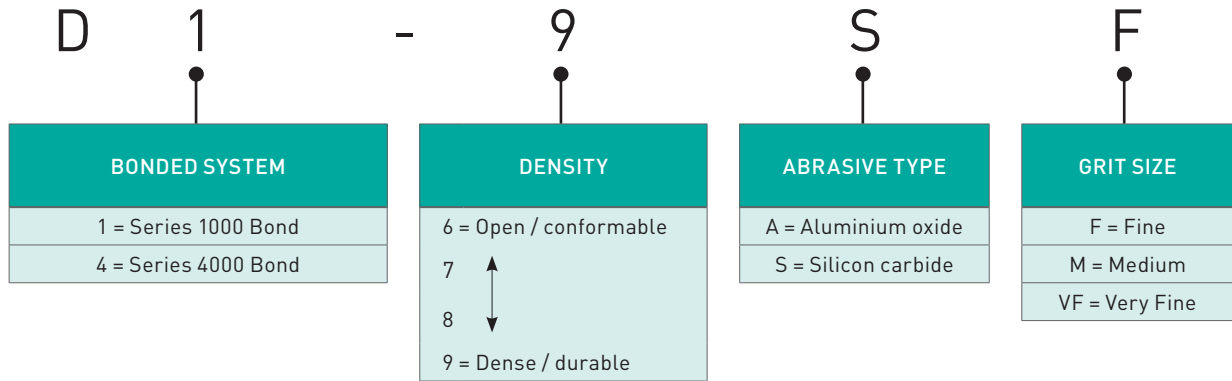

Use Series 1000 Long Life as the starting point for selection.

## QUICK PRODUCT SELECTION BY APPLICATION

APPLICATION AREA	SPECIFIC APPLICATION	SPECIFICATION	RECOMMENDED SPEEDS
Cleaning	General purpose cleaning, removing rust oxidation, corrosion, discolouration, flashings, pipe threads, machine parts, plastic moulded parts	DMA or D18 SF	11-32 ms/ 2 200 - 6 000 SFPM
Deburring	Removing medium to heavy burrs – deburring die cast/smoothing radii on metal parts/ blending coated abrasive scratch pattern	D19 SF	28-41 ms/ 5 500 - 8 000 SFPM
Blending	Smoothing parting lines, polishing welds, machine parts	D1 7 SF	28-41 ms/ 5 500 - 8 000 SFPM
Finishing	Satin finish, cosmetic finish, brush finish	D1 7 SF	2-15 ms/ 500 - 3 000 SFPM

## APPLICATION GUIDE

Pressure	<ul style="list-style-type: none"> <li>• Light to medium pressure is recommended for most operations</li> <li>• Avoid excessive pressure which may result in wheel deformation &amp; damage to the work surface</li> </ul>
Feed speed	<ul style="list-style-type: none"> <li>• Feed speeds directly affect the number of pieces completed over a given period of time</li> <li>• Slow feed speed reduces the number of workpieces completed, while producing a shorter scratch pattern</li> <li>• Slow feed speed allows for longer dwell time &amp; permits more work to be done on each piece</li> <li>• Conversely, a fast feed speed increases the number of workpieces completed</li> <li>• While producing a longer scratch pattern</li> </ul>
Oscillation	<ul style="list-style-type: none"> <li>• Oscillation may be used to break up scratch lines</li> <li>• Produce a more uniform finish</li> <li>• Additionally, an increase in cut may be experienced</li> <li>• A general starting point for oscillation is 3/8" amplitude at 200 cycles per minute</li> </ul>
Lubricants	<ul style="list-style-type: none"> <li>• Lubricants, such as water, water soluble oil &amp; straight oil, will decrease the heat generated while running, improve the luster &amp; improve the surface finish</li> <li>• The higher the viscosity of the lubricant, the lower the surface finish (RMS value) produced</li> </ul>

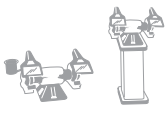

## UNDERSTANDING THE PRODUCT

SPECIFICATION	GRADE	MCC
DCS	VF	C4501
	F	C4401
	M	C4301
DSS	M	C4302
DSA	M	C2302
DMA	M	C2303
LFW S	F	C4411
D1 6 A LL	M	C2308
D1 7 A LL		
D1 8 A LL		
D1 9 A LL		
D1 6 S LL		
D1 7 S LL, D1 8 S LL, D1 9 S LL, D1 9 S LL	F	C4408
	M	C4308
D4 8 A	M	C2306
D4 8 S	F	C4406
D4 9 S	F	C4406

## PRODUCT SELECTION GUIDE

MATERIALS / APPLICATIONS	DEBURRING	CLEANING	BLEND/FINISH
Stainless Steel, Heat-sensitive alloys	C4407	C4308	C4308
Carbon Steel	C4308	C4308	C4308
Non-Ferrous Metal/Brass/Aluminium	C4308	C4301	C2303

COATED  
ABRASIVES  
& BEARTEX

BONDED  
ABRASIVES

SUPER  
ABRASIVES

DIAMOND  
TOOLS

CLEANING,  
POLISHING  
& MASKING

PERSONAL  
PROTECTION  
EQUIPMENT

TECHNICAL  
INFORMATION



# CONVOLUTE WHEELS

## CONVOLUTE WHEELS

DIM DxWxB(mm)	REF CODE	ABR TYPE	GRADE	MCC	DTY	PK QTY	GOOD				SERIES 1000 LONG LIFE	SERIES 4000		
							DCS	DSS SURFACE FINISHING	DMA METAL FINISHING	LFW LIGHT FINISHING				
150x10x25	D17	SiC	F	C4408	7	4						63642549767		
150x12x25	D17	SiC	F	C4408	7	4						66261018628		
		AlOx	M	C2308		4						66261018857		
		SiC		C4408		4						69957397880		
	D18	SiC	F	C4408	8	4						66261018773		
		AlOx	M	C2308		4						66261018789		
	D19	SiC	F	C4408	9	4						66261094584		
	D49	SiC	F	C4406	9	4							66261004021	
150x25x25	DMA	AlOx	M	C2303	5	3			66261007936					
	D16	AlOx	F	C2406	6	3						66261055204		
		AlOx	M	C2308		3						66261055205*		
		SiC	M	C4308		3						66261055202		
		SiC	F	C4411		3				66254403708*				
	D17	SiC	F	C4411 C4408	7	3				66254403709*	66261055223			
	D18	SiC	F	C4411 C4408	8	3			66254421573		66261018774			
	D19	SiC	F	C4408	9	3					0766705227			
	D19	SiC	M	C4308	9	3					66261055371			
	D48	SiC	F	C4406	8	3							66261008658	
		AlOx	M	C2306		3							66261004208	
	DSA	AlOx	M	C2302	n/a	4			66261058550*					
	DSS	SiC	CRS	C4202	n/a	4			66261058553					
150x50x25	DCS	SiC	F	C4401	n/a	2	63642549645							
	DCS	SiC	M	C4301	n/a	2	66261058510							
	DSS	SiC	M	C4302	n/a	2		66261058560*						
	DMA	AlOx	M	C2303	5	2			66261007957					
	D17	AlOx	F	C2406	7	2						66261008897*		
AlOx		M	C2308	3							66261055229*			
200x20x76	D19	SiC	S	C4408	M	3						66261023567		
200x25x76	DMA	AlOx	M	C2303	5	3			66261007831					
	D16	SiC	F	C4411 C4408	6	3				66261095702	66261019693			
			M	C4308		3				66261055208				
	D17	AlOx	F	C2406	7	3					69957352389*			
		SiC	F	C4411 C4408		3				66254409924	66261018639			
		AlOx	M	C2308		3						66261055232		
	D18	SiC	M	C4308	8	3					69957394610			
		SiC	F	C4411 C4408		3				66254421577	66261018775			
		AlOx	M	C2308		3						66261018855		
	SiC	M	C4308	3							66261018673			

\* Made-to-order

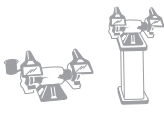

## CONVOLUTE WHEELS (CONTINUED)

DIM DxWxB(mm)	REF CODE	ABR TYPE	GRADE	MCC	DTY	PK QTY	DCS	DSS SURFACE FINISHING	DMA METAL FINISHING	SERIES 1000 LONG LIFE	SERIES 4000
							GOOD				
200x25x76	D19	SiC	F	C4408	9	3				66261018641	
		SiC	M	C4308		3				66261018997	
	D48	SiC	F	C4406	8	3					66261004123
		AlOx	M	C2306		3					66261004165
200x50x76	DCS	SiC	F	C4401	n/a	2	63642515565				
	DCS	SiC	M	C4301	n/a	2	07660705208				
	DMA	AlOx	M	C2303	5	2			66261007904		
	D16	SiC	M	C4308	6	2				66261055211	
		AlOx	F	C2406		2				66261009252*	
	D17	SiC	F	C4408	7	2				66261018877	
		AlOx	M	C2308		2				66261055235	
	D18	SiC	F	C4408	8	2				66261019629	
	D18	SiC	M	C4308	8	2				07660705226	
	D19	SiC	F	C4408	9	2				66261055276	
250x12x127	D17	SiC	F	C4408	7	4				69957352396*	
		SiC	F	C4408		4				66261019221	
	D18	AlOx	M	C2308	8	4				69957352395*	
		SiC		C4308		4				66261019005*	
D19	SiC	F	C4408	9	4				66261019222		
250x25x127	D18	AlOx	M	C2308	8	4				69957352402	
300x50x125	DSS	SiC	CRS	C4202	n/a	1		66261058574*			

\* Made-to-order

Refer to the accessories section at the back of this catalogue for information on metal bushings to reduce the bore size.

## BORE HOLE REDUCTION BUSHINGS

WHEEL BORE (mm)	SIZE OF REDUCED BORE WITH BUSHING (mm)	FOR WHEEL DIAMETER (mm)	PK QTY	ART. NO.
25	10	100 to 150	2	66261080522*
	13		2	66261080523
	16		2	66261080524*
	20		2	66261080525*
	22		2	66261080526*
50	13	150 to 200	2	66261082442*
50	13	150	2	66261080527*
	16		2	66261080528
	25		2	66261080529*
	32		2	66261080530*
76	25	200	2	66261080531
	32		2	66261080532
	50		2	66261080514*
125	32		2	66261080534

\* Made-to-order

**Dimensions Key:** DIM = Dimensions, D = Diameter, W = Width, B = Bore Hole, ABR = Abrasive Type, DTY = Density

COATED  
ABRASIVES  
& BEARTEX

BONDED  
ABRASIVES

SUPER  
ABRASIVES

DIAMOND  
TOOLS

CLEANING,  
POLISHING  
& MASKING

PERSONAL  
PROTECTION  
EQUIPMENT

TECHNICAL  
INFORMATION

# HIGH STRENGTH DISCS

Made of a strong nylon web impregnated with abrasive grain and resin, BearTex high strength discs are designed for demanding applications on a wide range of substrates. A general purpose product producing light satin finishes.

## APPLICATIONS & MARKETS

- Rust/oxide or coating removal
- Satin finishing of stainless steel cutlery
- Root finishing of titanium turbine blades
- Finishing of stainless steel & aluminium components
- Cleaning moulds & castings

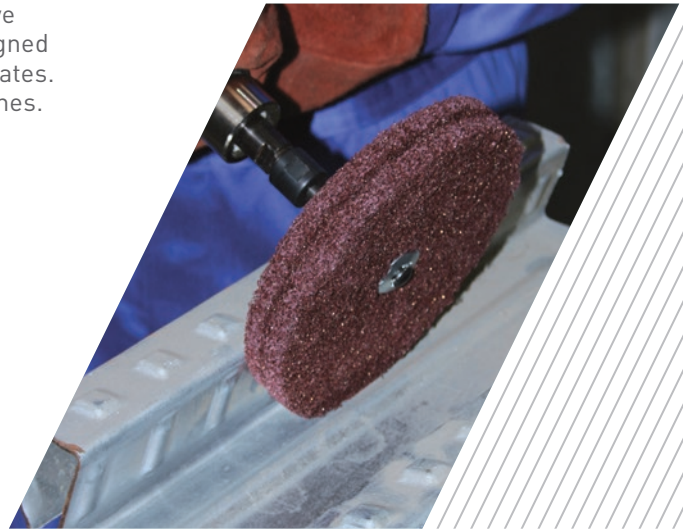

COATED  
ABRASIVES  
& BEARTEX

BONDED  
ABRASIVES

SUPER  
ABRASIVES

DIAMOND  
TOOLS

CLEANING,  
POLISHING  
& MASKING

PERSONAL  
PROTECTION  
EQUIPMENT

TECHNICAL  
INFORMATION

GOOD +++

## BEARTEX



**BearTex**®

### FEATURES

- Premium Aluminium Oxide grain combined with strong resin
- Flexible
- Tear resistant
- Can be ganged together to use as a wheel or mop

### BENEFITS

- Long life and clean cutting. Highly smear resistant!
- Follow surface contours
- Can be used for chamfering
- Helps avoid gouging or chunking the workpiece
- Forms a very flexible but durable wheel for bench or straight grinders

DIM DxB(mm)	CAP CODE	GRADE	PK QTY	ART. NO.
100x8	F2303	Medium	10	66254429562
150x12	F2303	Medium	10	77696087534
	F2506	Very Fine	10	77696087535
200x12	F2303	Medium	10	77696087536
	F2506	Very Fine	10	77696087537

For portable tools - Mount discs on mandrels - See Accessories page.

## BEARTEX LAP MOPS



DIA (mm)	CAP CODE	GRADE	MAX RPM	PK QTY	ART. NO.
150	F2520	Very Fine	4000	5	07660707529*
	F2503 High Strength	Medium	4000	5	63642573074*
	F2316 Heavy Duty	Medium	4000	5	63642573587*

\* Made-to-order

**Dimensions Key:** DIM = Dimensions, D = Diameter, B = Bore, DIA = Diameter

# 265-270 SATINEX MACHINE



266 Flap Wheels for Satinex Machines

268 Wheels for Satinex Machines

COATED ABRASIVES & BEARTEX

BONDED ABRASIVES

SUPER ABRASIVES

DIAMOND TOOLS

CLEANING, POLISHING & MASKING

PERSONAL PROTECTION EQUIPMENT

TECHNICAL INFORMATION

# FLAP WHEELS FOR SATINEX MACHINES

These versatile wheels are used on portable machines and are compatible with the most common used systems in the market. Satinex wheels consist of a core of radially bonded strips of abrasive flaps. Their design makes them ideal for fine grinding work on large areas and uneven surfaces while delivering a consistent finish with a uniform rate of cut.

The product structure, abrasive flaps anchored by a resin core at the centre, provides higher flexibility and very smooth surface finish.

Flange mounted flap wheels achieve their best performance at a recommended speed of 15-30m/s. At this speed, abrasive flaps stand up straight due to centrifugal force and only the edges are in contact with the workpiece, optimizing stock removal, surface finish, thermal load of the workpiece and toll wear.

**APPLICATIONS & MARKETS:** Flap wheels are an ideal choice for a wide variety of blending, deburring, finishing applications common in the metal fabrication, welding and polishing industries. Decorative finishing.



## SHAPE RECOMMENDATION GUIDE

### STANDARD FLAP WHEELS

Multipurpose product for use on portable machines where the wheel must fit on an existing 19,1mm arbor.



#### SPEC CHECK

To prevent unnecessary tool wear do not increase the contact pressure too much, the increase of stock removal should be achieved by using a coarser grit size.

To get a slightly finer surface increase the cutting speed.

To get a slightly rougher finishing increase the contact pressure. Using same grit size, the finishing is rougher on softer materials.



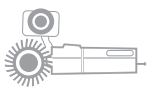

## X-TREME R822

BETTER ++++

**X-TREME**



The BETTER choice for stainless steel and resistant alloys.

### FEATURES

- Premium Zirconia alumina abrasive
- Semi-open coat

### BENEFITS

- For aggressive and quick operation
- Ideal for grinding, shaping, blending, edge breaking & weld
- High & regular cut rate
- Retards loading on aluminum
- Ensures perfect linear finish for repair & touch-up jobs

DIM DIAxWxS (mm)	GRIT			TYPE OF FLAP	RECOMMEND SPEED (RPM)	PK QTY
	P40	P60	P80			
100x50x19,1	66261139933	66261138387	66261138388	Standard	2900 - 5800	1
100x100x19,1	66261139934	66261138390	66261138391	Standard	2900 - 5800	1

Other grits and sizes available upon request.

COATED  
ABRASIVES  
& BEARTEX

BONDED  
ABRASIVES

SUPER  
ABRASIVES

DIAMOND  
TOOLS

CLEANING,  
POLISHING  
& MASKING

PERSONAL  
PROTECTION  
EQUIPMENT

TECHNICAL  
INFORMATION

## BDX R207

GOOD +++

**BDX**



The GOOD choice where superior finish is required or on low-pressure applications. Universal product for steel, stainless steel but also for paint removal, plastic or wood.

### FEATURES

- Premium aluminum oxide grain
- Flexible cotton backing

### BENEFITS

- For aggressive cut and longer life
- Excellent cut rate with ability to leave a very good finish
- Conformable to the workpiece
- Ensures perfect linear finish for repair & touch-up jobs

DIM DIAxWxS (mm)	GRIT			TYPE OF FLAP	RECOMMEND SPEED (RPM)	PK QTY
	P40	P60	P80			
100x50x19,1	66261139842	66261138372	66261138373	Standard	2900 - 5800	1
100x100x19,1	66261139847	66261138377	66261138378	Standard	2900 - 5800	1

Other grits and sizes available upon request.

**Dimensions Key:** DIM = Dimensions, DIA = Diameter, W = Width, S = Spindle

# WHEELS FOR SATINEX MACHINES

BearTex Satinex wheels provide a cushioned abrasive action which not only works well on flat areas, but is also ideal for use in finishing operations on uneven surfaces. These versatile wheels are used on portable machines.

## APPLICATIONS & MARKETS

- Decorative finishing
- Weld blending & Removing paint
- Removing scales oxide & rust
- For use on wood & stainless steel
- In-line brush finishes on stainless steel and aluminium cookware
- Producing fine scratch pattern prior to cotton buffing/compound polishing



COATED  
ABRASIVES  
& BEARTEX

BONDED  
ABRASIVES

SUPER  
ABRASIVES

DIAMOND  
TOOLS

CLEANING,  
POLISHING  
& MASKING

PERSONAL  
PROTECTION  
EQUIPMENT

TECHNICAL  
INFORMATION

GOOD +++

## BEARTEX



### FEATURES

- Key way fitting
- Used on portable, variable speed machines
- Wide range of different grades
- Advanced flap wheel construction

### BENEFITS

- High compatibility with most common systems in the market
- High mobility & flexibility
- From rust removal to a satin finish
- Ensures perfect linear finish for repair & touch-up jobs

*BearTex*®

## APPLICATION SELECTION

INDUSTRY	APPLICATION	PRODUCTS
Stainless steel fabricators	Grain finishing on sheets, removing imperfections	Satinex non-woven A Med
Architectural hardware	Finishing brass aluminium & steel, satin finishing	Satinex non-woven fine and very fine for bright linear finishes
Metal working	Cleaning and removing scales, oxide and rust	Satinex RapidStrip
Food processing	Weld blending, satin finishing with extended life	Satinex polyurethane

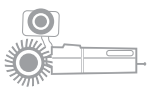

TYPE	APPLICATION	DIM DxTxB(mm)	CAP CODE	GRADE	MAX RPM	PK QTY	ART. NO.
Satinex Non Woven	Blending/Satin Finishing	110x100x19	F2200	A Coarse	5700	1	63642557218
			F2316	A Medium Heavy Duty	5700	1	66261124068
			F2300	A Medium	5700	1	63642557404
			F2400	A Fine	5700	1	63642557405
			F2402	A Fine	5700	1	07660707415
			F2504	A Very Fine	5700	1	63642557406
Satinex Interleaved	Blending/Fine Graining	110x100x19	F2200	A Course + P80	5700	1	63642557407
			F2309	A Medium + P80	5700	1	07660707431
			F2300	A Medium + P150	5700	1	63642557408
			F4402	S Fine + P150	5700	1	63642556741
Satinex Polyurethane	Blending/Satin Finishing	110x100x19	P2W01	Coarse	5700	1	63642557410
Satinex Rapid Strip	Cleaning/ Corrosion removal	110x100x19	R4101	Extra Coarse (SiC)	5700	1	63642557184
Satinex Non Woven	Cleaning/ Blending/ Finishing	110x50x19	F2200	A Coarse	5700	2	69957336455
			F2316	A Medium Heavy Duty	5700	2	66261124067
Satinex Interleaved	Blending/Fine Graining	110x50x19	F2200	A Course + P60	5700	2	66261180082

Other configurations and sizes available e.g. Interleaved, M14 centre etc.

**Dimensions Key:** DIM = Dimensions, D = Diameter, T = Thickness, B = Bore

COATED  
ABRASIVES  
& BEARTEX

BONDED  
ABRASIVES

SUPER  
ABRASIVES

DIAMOND  
TOOLS

CLEANING,  
POLISHING  
& MASKING

PERSONAL  
PROTECTION  
EQUIPMENT

TECHNICAL  
INFORMATION

## SATINEX KIT

APPLICATION	ART. NO.
SATINEX KIT: Satinex tool and assorted wheels	66254488427*
<p>A handy portable kit with everything contained to get you started on the Finish thanks to the speed and precision of the tool combined with the versatility of the Beartex Wheels.</p> <p>Contains Satinex tool and 6 assorted wheels.</p>	



\* Made-to-order

## PRODUCT SELECTION GUIDE

MATERIALS / APPLICATIONS	DEBURRING	CLEANING	BLEND/FINISH
All metal	F2200	F2300	F2402/F4306



# 271-272 WIDE BELTS

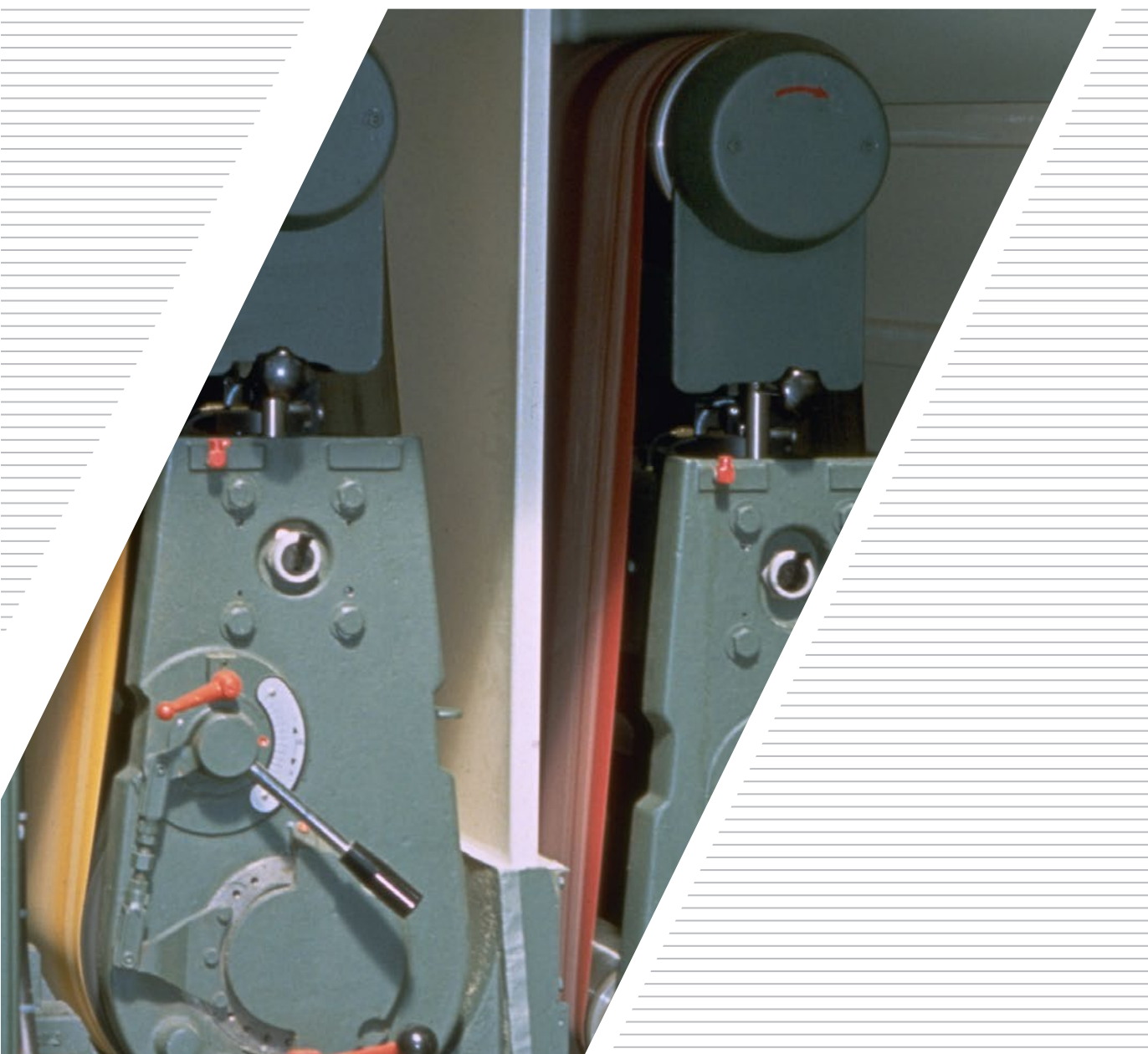

272 Wide Belts

COATED  
ABRASIVES  
& BEARTEX

BONDED  
ABRASIVES

SUPER  
ABRASIVES

DIAMOND  
TOOLS

CLEANING,  
POLISHING  
& MASKING

PERSONAL  
PROTECTION  
EQUIPMENT

TECHNICAL  
INFORMATION



# WIDE BELTS

Available in a range of sizes, suitable for finishing wood and metal.

## APPLICATIONS & MARKETS

### Metal Working

- Plate dimensioning
- Slag grinding
- Machining & deburring

### Wood Working

- Intermediate sanding
- Planing & dimensioning

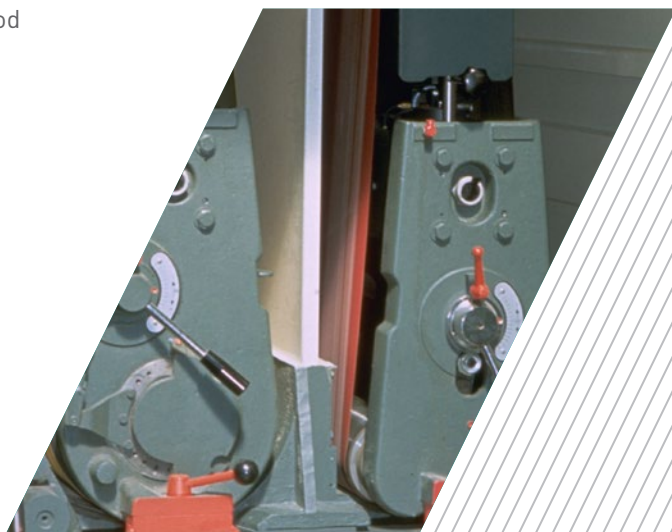

COATED ABRASIVES & BEARTEX

BONDED ABRASIVES

SUPER ABRASIVES

DIAMOND TOOLS

CLEANING, POLISHING & MASKING

PERSONAL PROTECTION EQUIPMENT

TECHNICAL INFORMATION

## H231

BEST +++++



### FEATURES

- Very strong F-weight paper
- High performance aluminium oxide abrasive
- Semi-open/open grain distribution
- Anti-static properties

### BENEFITS

- High performance & easy mounting
- Ideal for roughing, intermediate sanding & finishing of solid wood
- Ideal for furniture applications
- Finer grits ideal for polishing metal, plastics leather & smoothing fillers
- Resists clogging
- Excellent surface quality
- Less dust generated for an improved working environment

DIM WxL(mm)	GRIT	PK QTY	ART. NO.
1350x2620	150	10	69957337799*

\* Made-to-order

## PRODUCT SELECTION GUIDE

MATERIALS / APPLICATIONS		HIGHLY RECOMMENDED	RECOMMENDED	SUITABLE
Wood	Heavy stock removal	R293*	H231	H835*
	Callibration	H231		
	Finishing	H231		
	Between coats	A277*		

\* Made-to-order

**Dimensions Key:** DIM = Dimensions, W = Width, L = Length

# 273-284

## PRODUCTS FOR FLOOR, WALL & CEILING SANDING



COATED  
ABRASIVES  
& BEARTEX

BONDED  
ABRASIVES

SUPER  
ABRASIVES

DIAMOND  
TOOLS

CLEANING,  
POLISHING  
& MASKING

PERSONAL  
PROTECTION  
EQUIPMENT

TECHNICAL  
INFORMATION

274 Cloth Belts for Floor Sanding

277 Rolls for Floor Sanding  
279 Screenback Discs

280 Plain Discs  
282 Beartex Floor Pads

# CLOTH BELTS FOR FLOOR SANDING

A wide selection of sizes and grits for most dimensioning, intermediate grinding and polishing applications.

## APPLICATIONS & MARKETS

- Floor grinding
- Deburring
- Heavy stock removal
- Blending, dimensioning & shaping
- Finishing



COATED  
ABRASIVES  
& BEARTEX

BONDED  
ABRASIVES

SUPER  
ABRASIVES

DIAMOND  
TOOLS

CLEANING,  
POLISHING  
& MASKING

PERSONAL  
PROTECTION  
EQUIPMENT

TECHNICAL  
INFORMATION

## RED HEAT R955



### FEATURES

- Very strong polyester cloth backing
- SG ceramic abrasive
- High quality product

BEST +++++

INNOVATION

**REDHEAT**

### BENEFITS

- Extra long life & tear resistant
- Time saving
- Unmatched cut rate with optimum resistance to wear, ideal for professional floor sanding
- Best for use on hard wood & large jobs
- Less belt changes

## NORZON R817

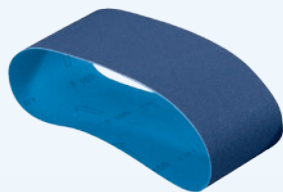

### FEATURES

- Heavy polyester cloth
- 100% Norzon abrasive
- Open grain distribution

BETTER ++++

**NorZon**

### BENEFITS

- Stiff tear resistant backing
- Long lasting cutting edges of Norzon brings long life even at high pressure
- Recommended for grinding soft materials like aluminium, plastic, rubber or leather
- Very good performance on hard wood



## R230

GOOD +++



NON  
FERR.



HARD WOOD  
& SOFT WOOD

### FEATURES

- Strong cloth backing
- Aluminium oxide abrasive
- Open grain distribution

### BENEFITS

- Multi-purpose Economy product ideal for sanding wooden floors & grinding metal
- Good cutting rate
- Reduced clogging

## R427



NON  
FERR.



HARD WOOD  
& SOFT WOOD

### FEATURES

- X-weight cotton cloth
- Silicon carbide abrasive

### BENEFITS

- Can be used for dry applications only
- Ideal for grinding glass & stone

COATED  
ABRASIVES  
& BEARTEX

BONDED  
ABRASIVES

SUPER  
ABRASIVES

DIAMOND  
TOOLS

CLEANING,  
POLISHING  
& MASKING

PERSONAL  
PROTECTION  
EQUIPMENT

TECHNICAL  
INFORMATION

## CLOTH BELTS FOR FLOOR SANDING

DIM WxL(mm)	GRIT	PK QTY	RED HEAT	NORZON	R230	R427
			R955	R817		
			BEST INNOVATION	BETTER	GOOD	
200x551	24	10			66254445468	
	36	10			66254445467	
	40	10			66254445466	
	60	10			63642588232	
	80	10			66254445465	
	100	10			69957372801	
	120	10			66254445464	
200x750	24	5	69957345034			
	24	10		66261182171	63642521182	63642552608
	36	5	69957345033			
	36	10		66261182172	69957349006	63642552610
	40	5	69957345032			
	40	10		66261182173	69957349007	63642552612
	50	5	69957345031			
	50	10				63642552613
	60	5	69957345030			
	60	10		69957371516	69957349010	63642552614
	80	5	69957345029			
	80	10			69957349014	63642552616
	100	5	69957345028			
	100	10		66261182174	69957349394	63642552618
120	10		69957371513	63642558814	63642552620	

**Dimensions Key:** DIM = Dimensions, W = Width, L = Length

COATED  
ABRASIVES  
& BEARTEX

BONDED  
ABRASIVES

SUPER  
ABRASIVES

DIAMOND  
TOOLS

CLEANING,  
POLISHING  
& MASKING

PERSONAL  
PROTECTION  
EQUIPMENT

TECHNICAL  
INFORMATION





# ROLLS FOR FLOOR SANDING

BETTER ++++

S413



**FEATURES**

- Very strong combination backing
- Sharp silicon carbide abrasive
- Very open grain distribution

**BENEFITS**

- High tear resistance
- Very high cutting action for rough floor sanding applications
- Long life
- Aggressive cut & clog resistant

S422



**FEATURES**

- Very strong combination backing
- Sharp silicon carbide abrasive

**BENEFITS**

- High tear resistance
- Very high cutting action on hard wood

NORZON R817



*NorZon*

**FEATURES**

- Heavy polyester cloth
- 100% Norzon abrasive
- Open grain distribution

**BENEFITS**

- High tear resistance
- Long lasting cutting edges of Norzon brings long life in floor sanding applications
- Reduces clogging

H425



**FEATURES**

- Strong E-weight paper
- Silicon carbide abrasive

**BENEFITS**

- Ideal for floor sanding
- Good tear resistance
- High cut rate

COATED  
ABRASIVES  
& BEARTEX

BONDED  
ABRASIVES

SUPER  
ABRASIVES

DIAMOND  
TOOLS

CLEANING,  
POLISHING  
& MASKING

PERSONAL  
PROTECTION  
EQUIPMENT

TECHNICAL  
INFORMATION

# ROLLS

## NORZON

DIM WxL	GRIT	PK QTY	S413	S422	R817	H425
			BETTER			
203mmx50M	16	1	63642512552*			
	24	1	63642512551*			
	30	1		63642539283		
	36	1		63642539286	63642514305	63642557681
	40	1				69957361909
	50	1		63642539292		69957352812
	60	1		63642539295	63642514309	63642527466
	80	1		63642539298	63642508570*	
	100	1				63642557683
254mmx50M	36	1			63642514312	63642539191
	40	1			63642514313	63642559644
	50	1			63642514314*	63642539194
	60	1				63642534759
	80	1				63642539198
	100	1				63642539200
	120	1				63642539203

\* Made-to-order

COATED  
ABRASIVES  
& BEARTEX

BONDED  
ABRASIVES

SUPER  
ABRASIVES

DIAMOND  
TOOLS

CLEANING,  
POLISHING  
& MASKING

PERSONAL  
PROTECTION  
EQUIPMENT

TECHNICAL  
INFORMATION



# SCREENBACK DISCS FOR WALL & CEILING SANDING

## SCREENBACK Q43N

**GOOD +++**



PAINT/VARN, PLASTER & FILLER, HARD WOOD & SOFT WOOD



### FEATURES

- Open-mesh structure
- Open self-gripping backing
- Inter-woven polyester knit backing
- Silicon carbide abrasive
- Waterproof

### BENEFITS

- Anti-clogging
- Longer life time
- To be used on machine with dust extractor for less dust when sanding
- High resistance
- More aggressive cut
- For wet and dry applications

DIA (mm)	GRIT	PK QTY	ART. NO.
225 	60	25	66623332303
	80	25	66623332310
	100	25	66623332311
	120	25	66623332313
	150	25	66623332318
	220	25	66623332322

## SCREENBACK Q421



PAINT/VARN, PLASTER & FILLER, HARD WOOD & SOFT WOOD



### FEATURES

- Silicon carbide abrasive on an open mesh backing

### BENEFITS

- Extreme resistance to loading
- Long life, waterproof

DIA (mm)	GRIT	PK QTY	ART. NO.
406 	60	10	66261120519
	80	10	63642536521
	100	10	66261120517
	120	10	66261120516
	150	10	63642536524
	180	10	63642515105
	220	10	63642552254

**Dimensions Key:** DIM = Dimensions, DIA = Diameter, W = Width, L = Length

## PRODUCT SELECTION GUIDE

MATERIALS / APPLICATIONS		HIGHLY RECOMMENDED	RECOMMENDED	SUITABLE
Wood - floor sanding	Surface preparation	S413	H425	
	Between coats	Q421		

COATED ABRASIVES & BEARTEX

BONDED ABRASIVES

SUPER ABRASIVES

DIAMOND TOOLS

CLEANING, POLISHING & MASKING

PERSONAL PROTECTION EQUIPMENT

TECHNICAL INFORMATION

# PLAIN DISCS

Norton offers a range of plain sanding discs to suit all the most commonly encountered applications.

## APPLICATIONS & MARKETS

- Preparing primed & painted surfaces
- Stripping primer & paint
- Sanding plastic & fibreglass
- Light weld blending & deburring
- Finishing metal



COATED  
ABRASIVES  
& BEARTEX

BONDED  
ABRASIVES

SUPER  
ABRASIVES

DIAMOND  
TOOLS

CLEANING,  
POLISHING  
& MASKING

PERSONAL  
PROTECTION  
EQUIPMENT

TECHNICAL  
INFORMATION

## H425

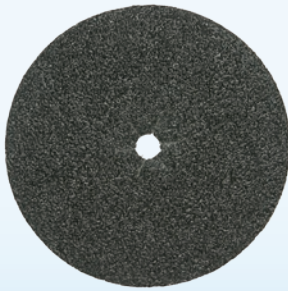

### FEATURES

- Silicon carbide abrasive
- Strong E-weight paper

### BENEFITS

- High cut rate
- For dry applications only
- Ideal for use on stone surfaces

BETTER ++++

## H231



### FEATURES

- High performance aluminium oxide abrasive
- Semi-open / open coat (depending on grit size)
- Very strong, F-weight paper
- Anti-static properties

### BENEFITS

- Ideal for roughing, intermediate sanding & finishing of solid wood
- Ideal for floor & furniture applications
- Finer grits ideal for polishing metal, plastics & leathers, smoothing fillers, sanding primers, within vehicle repair markets
- Resists clogging
- High performance
- Excellent surface quality



## PLAIN DISCS

DIM DIAxH(mm)	GRIT	PK QTY	H425		H231	
			BETTER			
140x22 ★	36	100	63642546555			
	60	100	63642546518			
	80	100	63642546519			
	120	100	69957360223			
150x12 ★	36	50	63642546553			
	40	100	69957360199			
	50	100	63642546525			
	60	100	63642546527			
	80	100	63642546529			
	100	100	69957360218			
185x22 ★	60	100	63642546548			
	80	100	63642546549			
	100	100	63642546550*			
350x40 ★	40	100			63642540076	
	50	100			63642540078	
	60	100			63642540079	
	80	100			63642540080	

## BEARTEX PLAIN DISCS

DIA (mm)	CAP CODE	GRADE	PK QTY	GOOD	
150	F2520	Very Fine A	10	63642557497	
	F4804	Ultra Fine S	10	63642557498	

**Dimensions Key:** DIM = Dimensions, DIA = Diameter, H = Hole

## PRODUCT SELECTION GUIDE

MATERIALS / APPLICATIONS		HIGHLY RECOMMENDED	RECOMMENDED	SUITABLE
Stone	Coarse sanding	S422		
	Finishing	H425		
Wood - floor sanding	Surface preparation	H231		

COATED  
ABRASIVES  
& BEARTEX

BONDED  
ABRASIVES

SUPER  
ABRASIVES

DIAMOND  
TOOLS

CLEANING,  
POLISHING  
& MASKING

PERSONAL  
PROTECTION  
EQUIPMENT

TECHNICAL  
INFORMATION



# BEARTEX FLOOR PADS

Beartex offers a wide range of floor pads from stripping right through to mirror gloss finishing. For general scrubbing and cleaning applications Beartex offers two pads that will remove surface dirt and grime to get the floor back in shape before recoating or buffing.

## APPLICATIONS & MARKETS

- Cleaning & polishing floors
- Factory & utility maintenance
- Janitorial applications



COATED  
ABRASIVES  
& BEARTEX

BONDED  
ABRASIVES

SUPER  
ABRASIVES

DIAMOND  
TOOLS

CLEANING,  
POLISHING  
& MASKING

PERSONAL  
PROTECTION  
EQUIPMENT

TECHNICAL  
INFORMATION

## STANDARD FLOOR PADS 25mm THICK

DIA (mm)	CAP CODE	GRADE	PK QTY	ART. NO.
406	JF175	White Super Gloss	5	63642585892
	JF176	Red Buffer	5	63642585890
	JF177	Beige	5	63642585873
	JF178	Black Super Strip	5	63642585841
	JF180	Green Super Scrub	5	63642585877
	JF181	Blue Super Clean	5	63642585868

All standard floor pads come with an 89mm removable centrepiece

## THIN LINE FLOOR PADS 15mm THICK

DIA (mm)	CAP CODE	GRADE	PK QTY	ART. NO.
406	JU014	Black	10	63642585895
	JF068	Green	10	63642585899
	JF040	Beige	10	63642585903
	JF175	White	10	63642585904

**Dimensions Key:** DIM = Dimensions, DIA = Diameter, H = Hole



### SPEC CHECK

- Designed to produce consistent performance & assure you a mirror gloss shine.



## PRODUCT SELECTION

Black Super Strip		A thick pad that is aggressive, durable, & consistent, for wet stripping applications
Green Super Scrub		A heavy duty wet scrubbing pad that will remove the toughest scuff marks in heavily soiled traffic areas
Blue Super Clean		For general duty scrubbing or heavy spray cleaning jobs
Beige		For buffing & polishing, good for light traffic areas
Red Buffer		Generally used where a high gloss finish is desired when dry or spray buffing. It can also be used for light cleaning applications
White Super Gloss		A non-abrasive polishing/buffing pad, used dry or with a fine mist to yield a mirror gloss shine

## PRODUCT SELECTION GUIDE

MATERIALS / APPLICATIONS	HIGHLY RECOMMENDED	RECOMMENDED	SUITABLE
Wood - floor sanding	JF178	JF181	JF177

COATED  
ABRASIVES  
& BEARTEX

BONDED  
ABRASIVES

SUPER  
ABRASIVES

DIAMOND  
TOOLS

CLEANING,  
POLISHING  
& MASKING

PERSONAL  
PROTECTION  
EQUIPMENT

TECHNICAL  
INFORMATION



# 285-288 SHOE MANUFACTURE & REPAIR



286 Belts

287 Cones

288 Naumkeag Caps

COATED  
ABRASIVES  
& BEARTEX

BONDED  
ABRASIVES

SUPER  
ABRASIVES

DIAMOND  
TOOLS

CLEANING,  
POLISHING  
& MASKING

PERSONAL  
PROTECTION  
EQUIPMENT

TECHNICAL  
INFORMATION

# SHOE MANUFACTURE & REPAIR

Shoe making and repair requires especially designed products for precision cleaning and finishing of leather and rubber. For this traditional business, Norton uses its long experience in abrasives to provide specially shaped products like naumkeag caps for fast and consistent result.

## APPLICATIONS & MARKETS

- Leather cleaning and preparation
- Rubber and leather soles shaping
- Glue removal



COATED  
ABRASIVES  
& BEARTEX

BONDED  
ABRASIVES

SUPER  
ABRASIVES

DIAMOND  
TOOLS

CLEANING,  
POLISHING  
& MASKING

PERSONAL  
PROTECTION  
EQUIPMENT

TECHNICAL  
INFORMATION

## NORZON R817



BETTER ++++

**NorZon**

### FEATURES

- Heavy polyester cloth
- 100% Norzon abrasive
- Open grain distribution

### BENEFITS

- Stiff tear resistant backing
- Long lasting cutting edges of Norzon brings long life even at high pressure

DIM WxL(mm)	GRIT	PK QTY	ART. NO.
40x1150	24	10	63642545912
40x1480	24	10	63642530673
	40	10	63642539334
	60	10	63642536456
	80	10	63642539379
	100	10	63642539376
40x1500	24	10	63642539381
40x1650	24	10	63642536454
	40	10	63642539336
	60	10	63642530675
	80	10	63642530677
	100	10	63642530676
	120	10	63642531859
70x1003	24	10	69957355880*
100x1480	24	10	63642519730*

\* Made-to-order





## CONES zco



**X-TREME**

### FEATURES

- Available in varying heights & diameters
- Mounted on expanded rubber drums
- Used for grinding, deburring & polishing

### BENEFITS

- Ideal for use on irregular shaped components such as curves, or recesses
- Easy fitting
- Useful for repair work in the shoe industry

DIM DBxDTxH (mm)	GRIT				RECOMMEND SPEED (RPM)	MANDREL CODE	PK QTY
	36	50	80	120			
20x14x63	66261176761	66261176657	66261176656	66261176540	19000 - 22000	07660740439	100
29x22x30	66261137713	63642513692	77696086972	77696081341	13000 - 15800	77696089374	100
36x22x60	63642520987	63642536572	63642545922	66261176703	10000 - 12500	07660740441	100

Other grits and sizes available upon request.

COATED  
ABRASIVES  
& BEARTEX

BONDED  
ABRASIVES

SUPER  
ABRASIVES

DIAMOND  
TOOLS

CLEANING,  
POLISHING  
& MASKING

PERSONAL  
PROTECTION  
EQUIPMENT

TECHNICAL  
INFORMATION

## BDX R265 CONES

**GOOD +++**

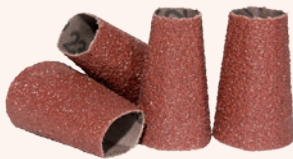

The GOOD choice for difficult-to-grind materials that require an economical option.

**BDX**

### FEATURES

- Premium aluminum oxide grain
- Selection of sizes & grades

### BENEFITS

- For aggressive cut and longer life
- Great for difficult-to-grind materials like aluminum and applications requiring an economical option
- Ideal for use on irregular shaped components such as curves, or recesses

DIM DBxDTxH (mm)	GRIT				RECOMMEND SPEED (RPM)	MANDREL CODE	PK QTY
	40	60	80	120			
20x14x63	66261137724	66261137688	66261137689	66261137691	19000 - 22000	07660740439	100
29x22x30	66261137717	66261137719	66261137720	66261137721	13000 - 15800	77696089374	100
36x22x60	66261137693	66261137696	66261137697	66261137698	10000-12500	07660740441	100

Other grits and sizes available upon request.

## RUBBER MANDREL FOR CONES



DIM DBxDTxH(mm)	SHAFT DIAMETER (mm)	MAX RPM	MIN RPM	PK QTY	ART. NO.
20x14x63	6mm	22000	15000	1	07660740439
29x22x30	6mm	15800	10500	1	77696089374
36x22x63	6mm	12500	8750	1	07660740441

**Dimensions Key:** DIM = Dimensions, W = Width, L = Length, DB = Base diameter, DT = Top diameter, H = Height

# NAUMKEAG CAPS K20N

GOOD +++



### FEATURES

- Aluminium oxide abrasive
- Open coat grain layer
- Flexible backing – bumped shape
- Left and right crimped direction

### BENEFITS

- Long lasting and consistent cut
- Anti-clogging effect
- Conforms perfectly to the profile of a shoe
- Perfect and smooth finish
- Adapts to machine axle rotation

DIA (mm)	CRIMP Direction	GRIT	PK QTY	ART. NO.
90	Left	60	25	63642520900
		80	25	63642520899
	Right	60	25	63642534616

Other grits available upon request.

**Dimensions Key:** DIA = Diameter

## PRODUCT SELECTION GUIDE

MATERIALS / APPLICATIONS	HIGHLY RECOMMENDED	RECOMMENDED	SUITABLE
Leather / shoe		R817	R265



### SPEC CHECK

- Choose proper crimp direction based on machine axle rotation.

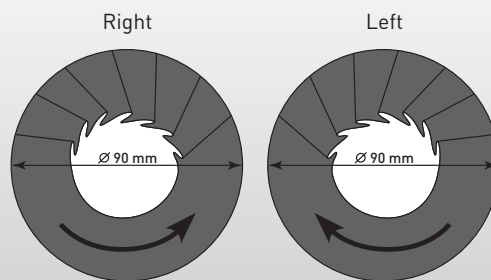

# 289-292 GLASS ARISING



290 Portable Belts

292 Cloth Belts

COATED  
ABRASIVES  
& BEARTEX

BONDED  
ABRASIVES

SUPER  
ABRASIVES

DIAMOND  
TOOLS

CLEANING,  
POLISHING  
& MASKING

PERSONAL  
PROTECTION  
EQUIPMENT

TECHNICAL  
INFORMATION

# GLASS ARISING

Norton provides a range of specially designed abrasive belts for the glass market. Our products provide fast work with minimal effort for a perfect finish.

## APPLICATIONS & MARKETS

- Edge breaking
- Beveling
- Finishing



COATED  
ABRASIVES  
& BEARTEX

BONDED  
ABRASIVES

SUPER  
ABRASIVES

DIAMOND  
TOOLS

CLEANING,  
POLISHING  
& MASKING

PERSONAL  
PROTECTION  
EQUIPMENT

TECHNICAL  
INFORMATION

## NORAX U366

BEST +++++



**NORAX**

### FEATURES

- Polyester cloth
- Special multi-layer abrasive products
- Aluminium oxide abrasive

### BENEFITS

- Generates a high quality finish
- Can be used wet
- Very long life & good cutting rate
- Increases productivity
- Grit X5 is ideal for final finishing of glass edges

## W445

BETTER ++++

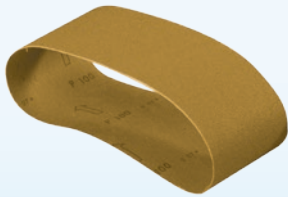

### FEATURES

- Polyester cloth
- Cork grain

### BENEFITS

- To be used wet or dry
- Ideal for final finishing of glass edges



## R427

**GOOD +++**



### FEATURES

- X-weight cotton cloth
- Silicon carbide abrasive

### BENEFITS

- Can be used for dry applications only
- Ideal for grinding glass & stone

## R445



### FEATURES

- Heavy to medium weight polyester cloth
- Silicon carbide abrasive

### BENEFITS

- Standard cloth for wet applications
- For use on glass, titanium or cast iron
- Ideal for use on stainless steel, especially for finer final finishing

## PORTABLE BELTS

			R427
DIM WxL(mm)	GRIT	PK QTY	GOOD
30x533	60	20	63642538954
	80	20	63642545903
	120	20	63642538955
	180	20	63642538957
75x604	60	10	63642539437
	120	10	63642539434
	180	10	63642545905

**Dimensions Key:** DIM = Dimensions, W = Width, L = Length

COATED ABRASIVES & BEARTEX

BONDED ABRASIVES

SUPER ABRASIVES

DIAMOND TOOLS

CLEANING, POLISHING & MASKING

PERSONAL PROTECTION EQUIPMENT

TECHNICAL INFORMATION



## CLOTH BELTS FOR GLASS ARISING

DIM WxL(mm)	GRIT	PK QTY	U366	W445	R445
			BEST	BETTER	GOOD
100x3350	60	10			63642546593
	80	10			63642546594
	100	10			63642530703
	120	10			63642546597
	150	10			63642546599
	180	10			63642546600
	220	10			63642546602
	240	10			63642546603
	400	10			63642546616
	CORK	10		63642545206	
X5 (3000)	10	63642518504*			
200x3350	80	10			63642546606*
	120	10			63642546608*
	180	10			63642546611*
	CORK	10		63642545218	

\* Made-to-order

### PRODUCT SELECTION GUIDE

MATERIALS / APPLICATIONS	HIGHLY RECOMMENDED	RECOMMENDED	SUITABLE
Glass	U366*	R427/W445	

\* Made-to-order

**Dimensions Key:** DIM = Dimensions, W = Width, L = Length

COATED  
ABRASIVES  
& BEARTEX

BONDED  
ABRASIVES

SUPER  
ABRASIVES

DIAMOND  
TOOLS

CLEANING,  
POLISHING  
& MASKING

PERSONAL  
PROTECTION  
EQUIPMENT

TECHNICAL  
INFORMATION

# 293-398 BONDED ABRASIVES



294 Introduction  
298 Application Guide  
301 Tool Grinding  
320 Saw Sharpening  
326 Surface Grinding  
342 External Cylindrical Grinding

350 Internal Cylindrical Grinding  
355 Bench And Pedestal Grinding  
366 Vitrified Mounted Points  
371 Dressing Sticks  
374 Bench & Combination Oil Stones

377 Abrasive & Precision Files  
382 Abrasive Slips & Specialties  
385 Cut-off Wheels  
393 Snagging Wheels & Cups  
396 Organic Mounted Points

BONDED ABRASIVES

SUPER ABRASIVES

DIAMOND TOOLS

CLEANING, POLISHING & MASKING

PERSONAL PROTECTION EQUIPMENT

TECHNICAL INFORMATION

# INTRODUCTION

From standard aluminum oxide bench wheels to premium ceramic abrasive surface grinding wheels, Norton offers high performance abrasive solutions that can maximise productivity in virtually all industrial applications.

The extensive product range is designed to meet all your precision grinding and roughing application needs, with all the most appropriate abrasive specifications, including grinding wheels, segments, mounted points, dressing sticks and sharpening stones.

Norton, the industry's most comprehensive Bonded abrasive product line.



## UNDERSTANDING THE PRODUCT

- 1 Safety pictograms
- 2 Strong Norton branding
- 3 Product dimensions (mm)
- 4 Product specification
- 5 Maximum operating speed
- 6 Article number; for use when re-ordering
- 7 oSa certified  
The Organisation for Safety of Abrasives
- 8 European safety standard EN 12413

## ABRASIVE TYPES

### CERAMIC ALUMINIUM OXIDE

Norton SG, Norton Quantum are patented ceramic forms of aluminium oxide that are harder and sharper than conventional abrasive grains. The ceramic grain has a unique microcrystalline structure and when used in a grinding operation this microstructure becomes self-sharpening. This leads to a reduction in the need for wheel dressing and a considerably cooler cutting action.

### ALUMINIUM OXIDE

Generally recommended for grinding materials of high tensile strength, such as stainless steel and tool steels, but it can also be used on some high tensile aluminium and bronze alloys. It is manufactured in varying qualities.

### SILICON CARBIDE

Harder than aluminium oxide with a very sharp abrasive grain shape. It is recommended for grinding relatively soft materials such as aluminium or cast iron as well as grinding extremely hard materials such as cemented carbide.

### ZIRCONIA ALUMINA

For use in rough grinding applications where high stock removal is required. Associated with high tech resin bonds.

BONDED  
ABRASIVES

SUPER  
ABRASIVES

DIAMOND  
TOOLS

CLEANING,  
POLISHING  
& MASKING

PERSONAL  
PROTECTION  
EQUIPMENT

TECHNICAL  
INFORMATION

## GRIT SIZE

The number in the grinding wheel, marking designating grit size, represents the approximate number of openings per linear inch in the final screen size used to size the grain. The following rules should be followed:

### USE COARSE GRIT

- For soft, ductile, stringy materials such as soft steel or aluminium
- For rapid stock removal
- Where finish is not important
- For large areas of contact.

### USE FINE GRIT

- For hard, brittle materials such as hard tool steels, cemented carbides & glass
- For fine finishes
- For small areas of contact
- For holding small corner radii.

## WHEEL GRADE

The grade indicates the relative holding power of the bond, which holds abrasive grains in a wheel. This is represented in the specification by letters running through the alphabet from softest to hardest. The following rules should be followed with regard to grade:

### USE SOFT GRADE

- For hard materials such as hard tool steels & carbides
- For large areas of contact
- For rapid stock removal.

### USE HARD GRADE

- For soft materials
- For small or narrow areas on contact
- For longer wheel life.

F	G	H	I	J	K	L	M	N	O	P	Q	R	S	T	U	
				CYLINDRICAL/CENTRELESS												
SURFACE GRINDING																
				ID GRINDING												
			TOOL GRINDING													
				THREAD GRINDING												
NON-REINFORCED ORGANIC																
										REINFORCED ORGANIC						

BONDED ABRASIVES

SUPER ABRASIVES

DIAMOND TOOLS

CLEANING, POLISHING & MASKING

PERSONAL PROTECTION EQUIPMENT

TECHNICAL INFORMATION

## BOND TYPES-VITRIFIED

Vitrified bonds are the most common precision grinding bond. Porosity and strength of the wheels made with this bond give high stock removal along with their rigidity helping to attain high precision. Not affected by water, acid, oils or ordinary temperature variations. The most common vitrified bonds are:

**VS3 / VS3P**

**NEW VITRIUM<sup>3</sup> REVOLUTIONARY BOND TECHNOLOGY**

**VITRIUM** 

The Vitrium<sup>3</sup> bond platform features an exclusive chemistry that delivers an entirely new grain adhesion science, resulting in improved product versatility across a wide range of precision grinding applications. Provides cool cutting, precise profile, high speed, versatile across all precision grinding applications.

**VS**

VS is a versatile, low temperature, vitrified bond system used in most precision applications.

**VX / VXP**

Equivalent to VS bond, for ceramic only.

**VQN / VQNP**

These bonds are associated with Norton Quantum technology - a versatile technology for low, medium and high force applications.

## UNDERSTANDING THE SPECIFICATION

ABRASIVE			GRIT SIZE			GRADE			STRUCTURE		BOND
ALUMINIUM OXIDE	SILICON CARBIDE	CERAMIC ALUMINIUM OXIDE	COARSE	MEDIUM	FINE	SOFT	MEDIUM	HARD	CLOSED	OPEN	
A		SGB			80	E	I	Q	8	10	VS
19A		3SG			90	F	J	R		11	VX
25A		5SG		46	100	G	K	S		12	VXP
38A			24	54	120	H	L	T			VXPM
			30	60			M				
57A			36	70			N				
86A							O				
IPA			46	60	80	ME	HA	EH	17	26	VTX
										20	
		3NQ		60	80	J	K	L	8		VQN
										12	VQNP
	37C		46	60	90	J	K	L	8		VS
	39C		54	70	100						
			80	120							
A		SGB	30	60	90	G	I	M	6	10	VS3
19A		2NQ	36	70	100	H	J	N	7	11	VS3P
38A		3NQ	46	80	120		K	O	8	12	
57A		5NQ	54		150		L			13	
86A											

BONDED ABRASIVES

SUPER ABRASIVES

DIAMOND TOOLS

CLEANING, POLISHING & MASKING

PERSONAL PROTECTION EQUIPMENT

TECHNICAL INFORMATION



## BOND TYPES-ORGANIC

These bonds are used in two types of wheels. Firstly, wheels used on portable or fixed machines for the rapid removal of metal. Secondly, cutting-off wheels either un-reinforced or reinforced, for use on portable or fixed machines. The most common organic bonds are:

### SNAGGING WHEELS & CUPS

B & B3	Foundry wheels: multi-purpose bond that gives satisfactory results on most applications
B28	Foundry wheels: high level bond suitable for most technical applications requiring high powered machines

### CUTTING-OFF WHEELS

BFX	<b>NEW</b> Foundry X bond technology designed to increase cut rate and wheel life in all cut-off applications on a wide range of tough materials
BF1	Specific bond ensuring the best quality of cut in dry or wet conditions
BF3	New generation bond assuring the best wheel life in dry cutting operations; versatile & long wheel life. Ideal for heavy duty operations
B24	New generation bond used on silicon carbide cut-off wheels that gives the best performance & the ultimate cut quality on non-ferrous metals in wet conditions
B25	Standard multi-purpose bond that offers durability & freeness of cut in a wide variety of materials & applications. Can also be used in wet cutting on softer grades
B26	New generation bond used on aluminium oxide cut-off wheels that gives the best performance & the ultimate cut quality on ferrous metals in wet conditions
B65	Traditional bond gives good performance & long wheel life in dry cutting conditions

## DIFFERENTIATION IN THE RANGE

Norton offers the industry's widest selection of sharpening and grinding wheels to meet every customer requirement. The range is classified into 3 tiers (Best/Better/Good) to help you choose the right product for your specific application according to the type of abrasive used.



Using unparalleled abrasive technology, & extremely high performance, high concentration ceramic aluminium oxide abrasive, Norton provides innovative products dedicated to improving productivity in all industrial applications



High concentrations of the well renowned SG abrasive are used to supply Norton's high performance abrasive grains, 5SG & 3SG. These products meet the demands of the most discerning user giving high stock removal rates & long product life for lower operating costs



The SGB abrasive is used in the majority of Norton's Better products. SGB contains a medium concentration of SG ceramic aluminium oxide abrasive. SG is harder & sharper than conventional abrasive grains & gives excellent cutting capability on a wide variety of materials



Standard aluminium oxide grains, both blended & pure, give highly durable solutions that produce good performance levels

For further information please go to the Technical Information Section at the back of this catalogue.

BONDED  
ABRASIVES

SUPER  
ABRASIVES

DIAMOND  
TOOLS

CLEANING,  
POLISHING  
& MASKING

PERSONAL  
PROTECTION  
EQUIPMENT

TECHNICAL  
INFORMATION

# APPLICATION GUIDE FOR PRECISION GRINDING

## TOOL GRINDING

PAGE 301 TO 319

Tool grinding refers to the maintenance and repair of the cutting tools used in manufacturing operations. Wheels of all sizes and shapes are used in tool and cutter applications. Most wheels used are vitrified, in grit sizes 36 to 220, and in grades H through to N.



## SAW SHARPENING

PAGE 320 TO 325

Saw sharpening refers to the maintenance and repair of saw blades. Vitrified flat wheels and cups are used in grit sizes 54 to 60. Resin treatment reinforces the wheel and helps reduce wheel face deformation.



## SURFACE GRINDING

PAGE 326 TO 341

The term surface grinding is used to describe the grinding of flat surfaces in which the wheel moves past the workpiece in a flat plane, or vice versa. Surface grinding applications range can vary from heavy rapid stock removal, to precision contour grinding.

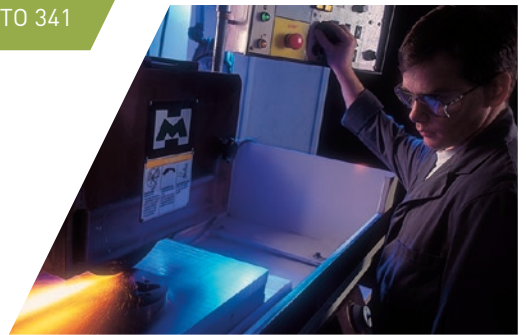

## EXTERNAL CYLINDRICAL GRINDING

PAGE 342 TO 349

Norton's leading technology, provides you with the best precision, formholding vitrified wheels to maximize productivity, increase grinding efficiency and improve part quality in all your external cylindrical grinding operations.



## INTERNAL CYLINDRICAL GRINDING

PAGE 350 TO 354

Internal grinding refers to the grinding of bores or holes and is probably one of the most difficult types of grinding. Internal grinding applications range from very rapid stock removal to more controlled processes capable of generating sizes and concentricity measured in microns.

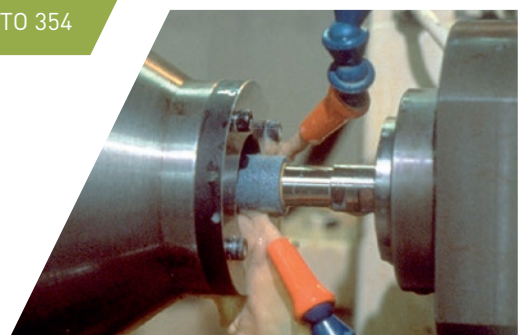

BONDED  
ABRASIVES

SUPER  
ABRASIVES

DIAMOND  
TOOLS

CLEANING,  
POLISHING  
& MASKING

PERSONAL  
PROTECTION  
EQUIPMENT

TECHNICAL  
INFORMATION

**BENCH AND PEDESTAL GRINDING** PAGE 355 TO 365

Bench and pedestral grinding application refers to offhand deburring and sharpening of parts and tools. The wheels are mounted on bench grinders or pedestral grinders and covers three types of abrasives to answer all deburring, shaping and sharpening needs: aluminum oxide for high speed tool steels and other metals, and silicon carbide for non-ferrous metals.



**REDUCTION RINGS**

Plastic reduction rings may be used to adapt grinding wheels to fit on various spindle sizes. These rings reduce the bore hole size, allowing the wheel to be safely mounted on a spindle with a smaller diameter.

- Reduction rings should never come in contact with the flange
- Reduction rings should not be used on wheels of thicknesses less than 6mm, or greater than 50mm
- Always use one reduction ring on each side of the wheel when the wheel is thick enough to allow correct seating
- Never use reduction rings to reduce the hole below the minimum specified in the FEPA safety code

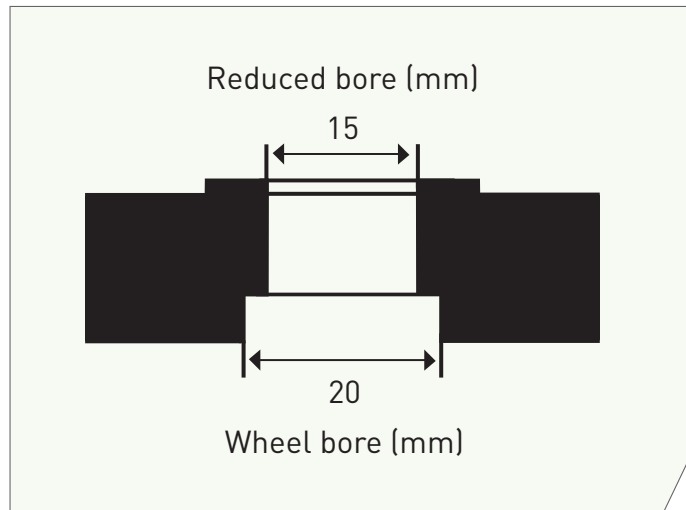

WHEEL BORE (mm)	REDUCED TO (mm)	REDUCTION RING
50,8	35	07660704766
32	25	07660717540
32	20	07660717538
31,75	15,88	07660704757
31,75	12,7	07660704755
20	16	07660717530
20	15	07660717529
20	13	07660717527
20	12	07660717525
20	10	07660717524
16	6	00510008919

BONDED ABRASIVES

SUPER ABRASIVES

DIAMOND TOOLS

CLEANING, POLISHING & MASKING

PERSONAL PROTECTION EQUIPMENT

TECHNICAL INFORMATION



# TOOL GRINDING

Norton vitrified grinding wheels have set the standard for generations – leading the way with technological improvements to maximise performance and productivity for your tool and cutter grinding and sharpening operations.

For Tool Grinding, please take note of the safety instructions, about the storage and use of grinding wheels, available on page 564.

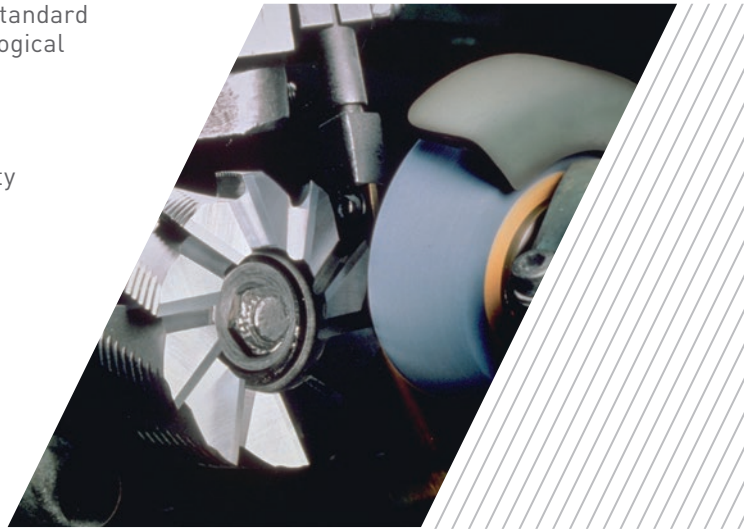

	STEELS						
	CHROME PLATE	HIGH SPEED STEEL	INOX	STEEL - S0FT (UP TO 45RC)	STEEL HARDENED (OVER 56RC)	STEEL-HIGH CARBON / HIGH CHROME CONTENT	STELLITE
NQ	X	X	X	X	X	X	X
SG / GF		X		X	X		
19A / 57A				X			
25A / 86A / 32A				X	X		
37C							
38A	X	X		X	X	X	X
39C			X				
A				X	X		

BONDED ABRASIVES

SUPER ABRASIVES

DIAMOND TOOLS

CLEANING, POLISHING & MASKING

PERSONAL PROTECTION EQUIPMENT

TECHNICAL INFORMATION

## NORTON QUANTUM WITH VITRIUM<sup>3</sup> 5NQ

BEST +++++

INNOVATION

### REVOLUTIONARY BOND TECHNOLOGY

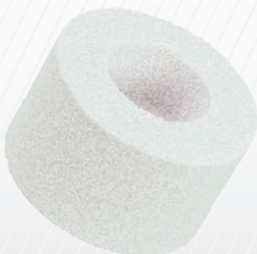

#### FEATURES

- Engineered ceramic grain shape and chemistry with new revolutionary bond
- Perfect combination of sharpness and toughness

#### BENEFITS

- Extreme versatility for all precision applications
- Reduced dressing frequency and cost
- High profile accuracy
- Cooler cut and high speed material removal



LINK TO WEBSITE AND ANIMATION



## NORTON QUANTUM 5NQ / 3NQ / 2NQ

BEST +++++



### FEATURES

- Engineered ceramic grain shape and chemistry with new bond technology
- A perfect blend between sharpness (free cutting) and toughness (life)

### BENEFITS

- Versatile in all low, medium and high force applications
- 30% to 100% higher metal removal rate
- >15% lower threshold power

## SG 5SG

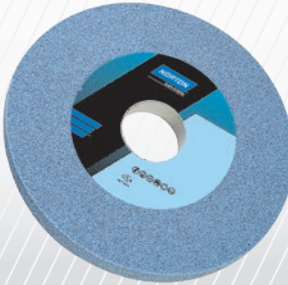

### FEATURES

- Very high concentration of SG ceramic aluminium oxide abrasive

### BENEFITS

- Ultimate cutting capability
- High removal rate & extended wheel life
- Perfect for technical applications where grinding parameters can be adjusted to optimise performance

## SG 3SG

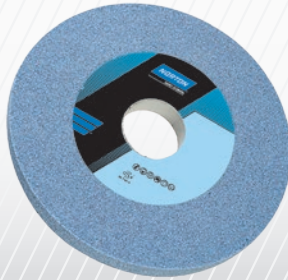

### FEATURES

- High concentration of SG ceramic aluminum oxide abrasive
- Unique, self sharpening, microcrystalline structure

### BENEFITS

- Very good cutting capability
- High removal rate & extended wheel life
- Suitable for very hard steels

BONDED  
ABRASIVES

SUPER  
ABRASIVES

DIAMOND  
TOOLS

CLEANING,  
POLISHING  
& MASKING

PERSONAL  
PROTECTION  
EQUIPMENT

TECHNICAL  
INFORMATION

## 38A WITH VITRIUM<sup>3</sup>

BETTER +++++

REVOLUTIONARY BOND TECHNOLOGY

VITRIUM 



### FEATURES

- High purity white aluminium oxide abrasives with enhanced bond adhesion
- High friability abrasive

### BENEFITS

- Even cooler & burn free cutting
- Extended wheel life
- Improved profile accuracy
- Ideal for heat sensitive applications with light to moderate feed rates



LINK TO WEBSITE  
AND ANIMATION

BONDED  
ABRASIVES

SUPER  
ABRASIVES

DIAMOND  
TOOLS

CLEANING,  
POLISHING  
& MASKING

PERSONAL  
PROTECTION  
EQUIPMENT

TECHNICAL  
INFORMATION

## SG SGA / SGB



### FEATURES

- Medium concentration of SG ceramic aluminium oxide
- Harder & sharper than conventional abrasive grains

### BENEFITS

- Good cutting capability
- Suitable for low to medium power machines
- Very versatile on a wide variety of steels

## 38A

GOOD +++



## FEATURES

- High purity white aluminium oxide abrasive
- Friable

## BENEFITS

- Cool & burn free cutting
- Ideal for heat-sensitive applications with light to moderate feed rates

## 86A



## FEATURES

- Highly refined pink aluminium oxide abrasive
- Tougher abrasive than pure white aluminium oxide
- Contains a small portion of chromium oxide

## BENEFITS

- Very versatile
- Reduced dress frequency

## 19A



## FEATURES

- A blend of A & 38A abrasives
- Primarily used in saw grinding applications

## BENEFITS

- Very versatile. For use on a wide variety of steels
- Good yield, good removal rate
- Good balance between cut rate & form holding ability

A



**FEATURES**

- Regular brown aluminium oxide abrasive
- Unique, self sharpening, microcrystalline structure

**BENEFITS**

- Very tough, suitable for grinding most types of steel & soft iron
- Good cost/performance compromise
- Hard wearing wheels for general purpose cylindrical off-hand bench & pedestal grinding applications

37C



**FEATURES**

- High purity black silicon carbide abrasive
- Harder & more friable than aluminum oxide abrasive

**BENEFITS**

- Suitable for roughing operations in coarse grit & resinoid wheels
- Ideal for grinding & sharpening applications on metal carbide & non-ferrous metals

39C

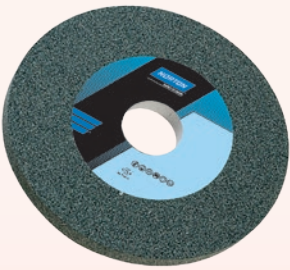

**FEATURES**

- Highest purity green silicon carbide abrasive
- Harder & more friable than aluminium oxide abrasive

**BENEFITS**

- Ideal for precision grinding & sharpening applications on metal carbide

BONDED ABRASIVES

SUPER ABRASIVES

DIAMOND TOOLS

CLEANING, POLISHING & MASKING

PERSONAL PROTECTION EQUIPMENT

TECHNICAL INFORMATION

## STRAIGHT WHEELS

DIM DxTxH (mm)	SHAPE	MOS (m/s)	PK QTY	SPECIFICATION	ART. NO.	BEST/ BETTER/ GOOD
<b>■ ■ ■ SHAPE 01</b>						
80x20x20	01	35	50	38A 60 L VS3	69210431529	BETTER
80x25x13	01	35	10	39C 60 M V	66253051623	GOOD
	01	45	10	37C 60 N V	69936668764	GOOD
80x25x12,7	01	45	6	39C 60 M V	66253051624	GOOD
100x10x20	01	45	2	38A 60 M VS	69936640015	GOOD
100x10x32	01	45	2	39C 80 L VS	66253050380	GOOD
100x13x32	01	45	2	38A 60 L VS	66253050409	GOOD
100x20x32	01	45	2	38A 60 L VS	66253050413	GOOD
125x6x32	01	35	5	38A 60 L VS	66253050440	GOOD
125x8x20	01	33	5	38A 60 L VS3	69210431218	BETTER
125x10x20	01	45	2	38A 60 M VS	69936640158	GOOD
125x10x32	01	45	2	38A 60 L VS	69936675731	GOOD
125x13x32	01	45	5	3SG 60 J VX	66253050290	BEST
125x16x20	01	33	5	25A 60 L VS3	69210431230	BETTER
	01	33	5	37C 60 K VK	69210431231	GOOD
	01	45	2	38A 60 M VS	69936640310	GOOD
125x16x32	01	45	2	38A 60 M VS	66253050237	GOOD
	01	33	5	39C 80 L VS	66253050393	GOOD
125x16x12,7	01	33	5	39C 60 J VK	69210434203	GOOD
125x20x20	01	33	5	37C 60 K VK	69210431169	GOOD
	01	35	5	38A 60 K VBE	69210431173	GOOD
	01	33	5	25A 60 L VS3	69210431241	BETTER
	01	35	4	39C 80 K VS	69936639669	GOOD
125x20x32	01	45	2	39C 80 L VS	69936667443	GOOD
	01	32	4	38A 60 L VS	69936675736	GOOD
150x4x20	01	45	2	38A 100 M VS	69936640219	GOOD
	01	45	2	38A 60 L VS	69936675591	GOOD
	01	45	2	38A 80 N VS	69936676720	GOOD
150x4x30	01	45	2	38A 80 N VS	69936639730	GOOD
150x4x32	01	63	2	39C 120 K VS	66253050248	GOOD
	01	63	2	19A 60 M VS	69936674920	GOOD
	01	35	2	19A 60 O VS	69936675946	GOOD
150x6x20	01	35	4	38A 80 M VS	69936639372	GOOD
	01	35	4	38A 60 M VS	69936639663	GOOD
	01	45	6	39C 100 K VS	69936639768	GOOD
	01	45	2	86A 80 O VS	69936686760	GOOD
150x6x32	01	45	2	3SG 80 L VX	66253054873	BEST
	01	45	2	3SG 60 L VX	66253055040	BEST
	01	35	2	39C 120 K VS	69936675617	GOOD
	01	63	2	38A 60 L VS	69936675741	GOOD
	01	35	2	19A 60 M VS	69936675964	GOOD
150x6x31,75	01	35	2	38A 80 L VS	69936621582	GOOD
150x7x20	01	35	5	39C 80 K VS	69936639933	GOOD

ART. NO. With **VITRIUM** Revolutionary bond technology



DIM DxTxH (mm)	SHAPE	MOS (m/s)	PK QTY	SPECIFICATION	ART. NO.	BEST/ BETTER/ GOOD
<b>SHAPE 01</b>						
150x8x20	01	35	5	37C 60 K VK	69210431420	GOOD
	01	35	5	38A 60 L VS3	69210431422	BETTER
	01	45	6	38A 60 M VS	69936638711	GOOD
	01	45	2	86A 80 O VS	69936686743	GOOD
150x8x32	01	45	2	3SG 60 J VX	66253055041	BEST
	01	45	2	38A 60 L VS	69936675743	GOOD
	01	35	5	38A 120 J VS	69936675748	GOOD
150x10x20	01	35	5	38A 60 L VS3	69210431426	BETTER
	01	45	2	38A 60 L VS	69936676539	GOOD
150x10x32	01	45	2	19A 60 O VS	66253050201	GOOD
	01	45	2	3SG 60 L VX	66253050280	BEST
	01	45	2	39C 80 K VS	66253050357	GOOD
	01	45	2	38A 80 M VS	66253050373	GOOD
	01	45	2	38A 60 K VS	66253051070	GOOD
	01	45	2	39C 120 K VS	69936675629	GOOD
	01	45	2	38A 60 L VS	69936675744	GOOD
	01	45	2	38A 120 J VS	69936675749	GOOD
150x13x20	01	45	2	38A 60 L VS	69936640299	GOOD
150x13x32	01	45	2	3SG 60 L VX	66253050142	BEST
	01	45	2	38A 60 L VS	69936639340	GOOD
	01	35	2	38A 46 L VS	69936675754	GOOD
	01	45	2	38A 60 L VS	69936675757	GOOD
	01	45	2	38A 60 N VS	69936675758	GOOD
	01	45	2	38A 80 L VS	69936675759	GOOD
	01	45	2	38A 120 J VS	69936675760	GOOD
150x13x31,75	01	35	2	38A 60 K VS3	66253353664	BETTER
	01	50	2	39C 60 K VS	69936621564	GOOD
	01	35	2	3SG 60 K VS	69936622862	BEST
150x16x20	01	35	5	25A 60 L VS3	69210431349	BETTER
	01	35	5	37C 60 K VK	69210431352	GOOD
	01	35	4	38A 60 M VS	69936639923	GOOD
	01	35	2	39C 80 K VS	69936641095	GOOD
150x16x32	01	45	5	3SG 60 L VX	66253050367	BEST
	01	45	2	38A 60 M VS	69936640238	GOOD
	01	45	2	39C 80 L VS	69936675657	GOOD
	01	45	2	39C 120 K VS	69936675659	GOOD
	01	45	2	38A 46 L VS	69936675763	GOOD
	01	45	2	38A 60 L VS	69936675764	GOOD
150x16x32	01	45	2	38A 80 L VS	69936675767	GOOD
	01	35	5	3SG 60 H VXP	69936677177	BEST

BONDED  
ABRASIVES

SUPER  
ABRASIVES

DIAMOND  
TOOLS

CLEANING,  
POLISHING  
& MASKING

PERSONAL  
PROTECTION  
EQUIPMENT

TECHNICAL  
INFORMATION

Dimensions Key: DIM: Dimensions, D: Diameter, T: Thickness, H: Hole

MOS: Maximum Operating Speed,  
PK QTY: Packaging Quantity

## STRAIGHT WHEELS

DIM DxTxH (mm)	SHAPE	MOS (m/s)	PK QTY	SPECIFICATION	ART. NO.	BEST/ BETTER/ GOOD
<b>SHAPE 01</b>						
150x20x20	01	35	5	37C 60 K VK	69210431280	GOOD
	01	35	5	39C 60 K VK	69210431294	GOOD
	01	35	5	25A 60 L VS3	69210431387	BETTER
	01	35	5	39C 60 J VK	69210432298	GOOD
	01	35	4	38A 46 M VS	69936639373	GOOD
	01	35	4	39C 100 J VS	69936640003	GOOD
	01	35	4	39C 80 K VS	69936641410	GOOD
	01	45	2	SGB 60 M VX	69936678981	BETTER
150x20x32	01	45	5	38A 100 J VS	66243570493	GOOD
	01	45	2	SGB 60 K VX	66253049874	BETTER
	01	45	2	SGB 100 J VX	66253049895	BETTER
	01	45	2	3SG 60 K VX	66253050155	BEST
	01	45	2	38A 46 M VS	66253050372	GOOD
	01	45	2	38A 60 K VS	66253051065	GOOD
	01	45	2	38A 80 K VS	66253051067	GOOD
	01	35	2	37C 60 K VK	69210431299	GOOD
	01	35	2	38A 60 L VS	69936638508	GOOD
	01	45	2	38A 80 L VS	69936639416	GOOD
	01	45	2	38A 60 L VS	69936641391	GOOD
	01	45	2	38A 60 N VS	69936641392	GOOD
	01	45	2	39C 60 K VS	69936641411	GOOD
	01	45	2	39C 80 L VS	69936641413	GOOD
	01	35	2	39C 120 K VS	69936641414	GOOD
	01	35	5	38A 46 L VS	69936675771	GOOD
150x20x12,7	01	45	5	39C 60 J VK	69210434204	GOOD
150x20x31,75	01	35	2	38A 60 K VS3	66253353966	BETTER
	01	35	5	39C 100 K VS	69936623221	GOOD
150x25x20	01	35	4	38A 60 M VS	69936639805	GOOD
	01	45	2	39C 80 K VS	69936641429	GOOD
150x25x32	01	45	2	39C 80 K VS	66253050278	GOOD
	01	45	2	38A 60 M VS	66253050381	GOOD
	01	45	2	38A 60 K VS	66253050452	GOOD
	01	45	2	39C 60 K VS	69936675661	GOOD
	01	35	2	39C 120 K VS	69936675664	GOOD
	01	45	2	38A 60 L VS	69936675779	GOOD
150x3,2x32	01	45	2	19A 60 M VS	69936675941	GOOD
175x4x51	01	45	5	19A 60 M VS	66253052709	GOOD
175x20x32	01	45	2	39C 60 J VK	69210434205	GOOD
180x6x32	01	35	2	38A 60 L VS	69936675784	GOOD
180x6x31,75	01	63	2	38A 60 K VS3	66253353968	BETTER
	01	45	2	38A 46 K VS3	66253353969	BETTER
180x10x32	01	45	2	38A 80 J VS	69936675781	GOOD

ART. NO. With **VITRIUM** Revolutionary bond technology

DIM DxTxH (mm)	SHAPE	MOS (m/s)	PK QTY	SPECIFICATION	ART. NO.	BEST/ BETTER/ GOOD
<b>SHAPE 01</b>						
180x13x32	01	45	2	3SG 120 J VX	66253054874	BEST
	01	35	2	3SG 80 J VX	66253054892	BEST
	01	45	2	3NQ 60 I VS3	66253348361	BEST
	01	45	2	2NQ 46 I VS3	66253348363	BEST
	01	35	2	SGB 60 J VX	69936639148	BETTER
	01	35	2	SGB 60 H VXP	69936639168	BETTER
	01	45	2	38A 60 J VS	69936675794	GOOD
	01	45	2	38A 60 L VS	69936675797	GOOD
	01	45	2	38A 80 L VS	69936675801	GOOD
	01	45	2	38A 120 J VS	69936675802	GOOD
	01	50	2	3SG 60 G VXP	69936677178	BEST
180x13x31,75	01	50	2	SGA 46 K VX	66253121996	BETTER
	01	63	2	SGA 60 K VS	66253121997	BETTER
	01	63	2	38A 46 K VS3	66253353972	BETTER
	01	35	2	38A 60 K VS3	66253353974	BETTER
	01	50	2	38A 100 L VS	69936623220	GOOD
	01	35	2	3SG 46 K VS	69936623227	BEST
	01	35	2	3SG 60 K VS	69936623231	BEST
	01	50	2	38A 80 L VS	69936623239	GOOD
	01	35	2	SGB 46 K VX	69936623240	BETTER
	01	50	2	39C 100 J VS	69936623248	GOOD
	01	35	2	SGB 60 K VX	69936623255	BETTER
	01	35	2	38A 60 J VS	69936623266	GOOD
	01	50	2	38A 46 J VS	69936623274	GOOD
	01	50	2	3SG 100 J VS	69936623276	BEST
	01	35	2	SGB 70 H VXP	69936623463	BETTER
180x16x32	01	45	2	38A 60 K VS	66253050453	GOOD
	01	35	2	SGB 70 G VXP	69936639169	BETTER
	01	35	2	3SG 60 H VXP	69936677179	BEST
180x16x31,75	01	35	2	SGB 100 I VX	69936679001	BETTER

BONDED  
ABRASIVES

SUPER  
ABRASIVES

DIAMOND  
TOOLS

CLEANING,  
POLISHING  
& MASKING

PERSONAL  
PROTECTION  
EQUIPMENT

TECHNICAL  
INFORMATION

Dimensions Key: DIM: Dimensions, D: Diameter, T: Thickness, H: Hole

MOS: Maximum Operating Speed,  
PK QTY: Packaging Quantity

## STRAIGHT WHEELS

DIM DxTxH (mm)	SHAPE	MOS (m/s)	PK QTY	SPECIFICATION	ART. NO.	BEST/ BETTER/ GOOD
<b>SHAPE 01</b>						
180x20x32	01	45	2	3SG 60 H VXP	66243593654	BEST
	01	45	2	SGB 60 K VX	66253049878	BETTER
	01	45	2	SGB 46 H VXP	69936638723	BETTER
	01	45	2	32A 46 K VS	69936639590	GOOD
	01	45	2	38A 60 L VS	69936641395	GOOD
	01	45	2	39C 60 K VS	69936641415	GOOD
	01	45	2	39C 120 K VS	69936675666	GOOD
	01	35	2	38A 60 J VS	69936675810	GOOD
	01	45	2	3SG 60 J VS	69936676044	BEST
	01	50	2	39C 80 L VS	69936676582	GOOD
180x20x31,75	01	35	2	3SG 46 K VS	69936623242	BEST
	01	35	2	38A 46 L VS	69936623312	GOOD
	01	35	2	38A 60 L VS	69936623472	GOOD
	01	50	2	39C 60 K VS	69936623477	GOOD
	01	35	2	SGB 60 K VX	69936623480	BETTER
180x25x32	01	45	2	39C 80 L VS	69936667101	GOOD
	01	45	2	39C 60 K VS	69936675667	GOOD
	01	63	2	38A 60 L VS	69936675812	GOOD
200x4x32	01	45	2	19A 60 O VS	69936675986	GOOD
200x6x32	01	45	2	38A 60 M VS	66253050455	GOOD
	01	45	2	38A 80 N VS	69936639662	GOOD
	01	63	6	39C 120 K VS	69936675636	GOOD
	01	45	2	19A 60 M VS	69936675988	GOOD
	01	35	2	SGB 120 J VX	69936677029	BETTER
200x6x31,75	01	35	4	38A 120 I VS	69936640156	GOOD
200x8x20	01	35	5	SGB 60 O VX	69936688864	BETTER
200x8x32	01	35	5	38A 60 L VS3	69210431430	BETTER
	01	63	6	37C 60 K VK	69210432065	GOOD
	01	63	6	38A 60 M VS	69936658078	GOOD
	01	63	6	19A 60 M VS	69936675990	GOOD
200x10x32	01	63	2	86A 54 O VS	66253050147	GOOD
	01	35	5	38A 60 L VS3	66253348277	BETTER
	01	35	5	38A 60 K VBE	69210431394	GOOD
	01	45	2	37C 60 K VK	69210431914	GOOD
	01	45	2	SGB 60 J VX	69936639157	BETTER
	01	35	2	SGB 80 J VX	69936639158	BETTER
	01	45	2	39C 100 K VS	69936639461	GOOD
	01	45	2	39C 120 K VS	69936675637	GOOD
	01	45	2	38A 60 L VS	69936675818	GOOD
200x10x32	01	35	2	38A 120 J VS	69936675819	GOOD
200x10x32	01	35	2	38A 60 N VS	69936688303	GOOD
200x10x31,75	01	35	4	38A 120 I VS	69936640286	GOOD
	01	63	2	SGB 100 I VX	69936679003	BETTER

ART. NO. With **VITRIUM** Revolutionary bond technology

DIM DxTxH (mm)	SHAPE	MOS (m/s)	PK QTY	SPECIFICATION	ART. NO.	BEST/ BETTER/ GOOD
<b>SHAPE 01</b>						
200x13x32	01	45	2	38A 60 L VS3	66253348352	BETTER
	01	45	2	SGB 60 J VX	69936639160	BETTER
	01	45	2	38A 60 J VS	69936675821	GOOD
	01	45	2	38A 60 L VS	69936675823	GOOD
	01	45	2	39C 80 J VS	69936676152	GOOD
	01	50	2	SGB 120 J VX	69936676608	BETTER
200x13x31,75	01	50	2	SGA 46 K VX	66253122005	BETTER
	01	50	2	38A 60 K VS3	66253354044	BETTER
	01	50	2	3SG 46 K VS	69936623236	BEST
	01	35	2	3SG 60 K VS	69936623241	BEST
200x16x32	01	35	2	38A 60 L VS	69936675825	GOOD
200x16x31,75	01	45	2	38A 120 I VS	69936639656	GOOD
200x16x76,2	01	35	4	38A 60 L VS	69936675827	GOOD
200x20x20	01	45	2	39C 100 J VS	69936639897	GOOD
	01	45	2	39C 80 M VS	69936640220	GOOD
	01	35	4	39C 80 K VS	69936641417	GOOD
	01	45	5	SGB 60 M VX	69936678982	BETTER
200x20x32	01	45	2	SGB 60 K VX	66253049887	BETTER
	01	45	2	38A 46 K VS	66253051075	GOOD
	01	45	2	38A 60 K VS	66253051077	GOOD
	01	45	2	38A 80 K VS	66253051080	GOOD
	01	45	2	3NQ 46 J VQN	66253261995	BEST
	01	45	2	2NQ 60 I VS3	66253357059	BEST
	01	35	5	25A 46 L VS3	69210431318	BETTER
	01	35	5	25A 60 L VS3	69210431320	BETTER
	01	35	5	37C 120 K VK	69210431329	GOOD
	01	35	5	37C 46 K VK	69210431333	GOOD
	01	35	5	37C 80 K VK	69210431339	GOOD
	01	35	5	39C 60 J VK	69210431381	GOOD
	01	45	5	39C 60 K VK	69210431384	GOOD
	01	35	5	37C 60 J VK	69210431673	GOOD
	01	35	5	37C 60 K VK	69210431674	GOOD
	01	35	5	39C 80 K VK	69210431685	GOOD
	01	45	2	SGB 46 H VX	69936639171	BETTER
	01	35	2	SGB 60 H VXP	69936639172	BETTER
	01	45	2	38A 46 K VS	69936640300	GOOD
	01	35	2	38A 60 J VS	69936641401	GOOD
01	45	2	38A 60 L VS	69936641402	GOOD	
01	35	2	39C 60 K VS	69936641418	GOOD	

BONDED  
ABRASIVES

SUPER  
ABRASIVES

DIAMOND  
TOOLS

CLEANING,  
POLISHING  
& MASKING

PERSONAL  
PROTECTION  
EQUIPMENT

TECHNICAL  
INFORMATION

Dimensions Key: DIM: Dimensions, D: Diameter, T: Thickness, H: Hole

MOS: Maximum Operating Speed,  
PK QTY: Packaging Quantity



## STRAIGHT WHEELS

DIM DxTxH (mm)	SHAPE	MOS (m/s)	PK QTY	SPECIFICATION	ART. NO.	BEST/ BETTER/ GOOD
<b>SHAPE 01</b>						
200x20x32	01	45	2	39C 80 L VS	69936641420	GOOD
	01	45	2	39C 120 K VS	69936641421	GOOD
	01	45	2	38A 46 H VS	69936675551	GOOD
	01	45	2	3SG 46 J VS	69936675951	BEST
	01	45	2	39C 80 K VS	69936676351	GOOD
	01	45	2	3SG 60 H VXP	69936677181	BEST
200x20x50	01	35	2	3SG 60 J VX	66253050362	BEST
	01	35	2	38A 60 J VS	69936639462	GOOD
	01	45	2	38A 46 K VS	69936641104	GOOD
200x20x51	01	45	2	SGB 60 J VX	69936639251	BETTER
200x20x51	01	35	2	39C 60 K VS	69936640176	GOOD
200x20x76	01	35	2	3SG 60 I VS	69936639744	BEST
	01	35	2	38A 60 I VS	69936639978	GOOD
	01	50	2	38A 46 K VS	69936641077	GOOD
200x20x31,75	01	63	2	38A 60 K VS3	66253354038	BETTER
	01	35	2	38A 46 K VS3	66253354039	BETTER
	01	50	2	3SG 60 K VS	69936623667	BEST
	01	50	2	3SG 46 K VX	69936623774	BEST
	01	35	2	SGB 70 H VXP	69936623902	BETTER
	01	35	2	3SG 60 G VSPF	69936640249	BEST
200x20x50,8	01	45	2	38A 120 H VS	69936640514	GOOD
	01	45	2	3SG 60 H VXP	66243593696	BEST
	01	45	2	38A 60 K VS	66253049967	GOOD
	01	50	2	3SG 46 I VXP	66253052711	BEST
	01	45	2	3SG 46 K VS	69936623654	BEST
	01	45	2	38A 46 J VS	69936675832	GOOD
	01	35	2	38A 60 H VS	69936675834	GOOD
200x20x76,2	01	45	2	3SG 46 J VS	69936676018	BEST
200x25x20	01	45	2	3SG 46 H VX	66253050156	BEST
	01	35	4	38A 60 K VBE	69210432867	GOOD
	01	35	2	38A 60 M VS	69936641405	GOOD
200x25x32	01	45	2	39C 80 K VS	69936641422	GOOD
	01	45	2	38A 100 J VS	66243570496	GOOD
	01	45	2	SGB 60 K VX	66253049888	BETTER
	01	45	2	39C 80 K VS	66253050276	GOOD
	01	45	2	39C 100 J VS	66253050375	GOOD

BONDED  
ABRASIVES

SUPER  
ABRASIVES

DIAMOND  
TOOLS

CLEANING,  
POLISHING  
& MASKING

PERSONAL  
PROTECTION  
EQUIPMENT

TECHNICAL  
INFORMATION

ART. NO. With **VITRIUM** Revolutionary bond technology

DIM DxTxH (mm)	SHAPE	MOS (m/s)	PK QTY	SPECIFICATION	ART. NO.	BEST/ BETTER/ GOOD
<b>SHAPE 01</b>						
200x25x32	01	45	2	38A 60 M VS	66253051079	GOOD
	01	45	2	38A 80 K VS	66253051082	GOOD
	01	45	2	3SG 60 J VX	66253054889	BEST
	01	35	5	37C 80 K VK	69210431360	GOOD
	01	35	5	39C 60 J VK	69210431397	GOOD
	01	35	5	39C 60 K VK	69210431399	GOOD
	01	35	5	25A 60 L VS3	69210431408	BETTER
	01	35	5	37C 46 K VK	69210431421	GOOD
	01	35	5	37C 60 K VK	69210431423	GOOD
	01	35	4	38A 46 L VS	69936627127	GOOD
	01	45	2	38A 60 M VS	69936639846	GOOD
	01	45	2	38A 60 L VS	69936641407	GOOD
	01	35	2	39C 60 K VS	69936641424	GOOD
	01	45	2	39C 80 L VS	69936641427	GOOD
	01	45	2	39C 120 K VS	69936641428	GOOD
	01	35	2	39C 46 L VS	69936675639	GOOD
200x25x31,75	01	35	2	39C 100 K VS	69936623599	GOOD
	01	35	2	38A 60 L VS	69936623794	GOOD
	01	35	2	39C 60 K VS	69936623912	GOOD
200x32x32	01	45	2	SGB 60 K VX	66253049892	BETTER
	01	35	5	38A 46 M VS	66253052712	GOOD
	01	35	5	37C 60 K VK	69210431684	GOOD
	01	35	5	39C 60 J VK	69210432544	GOOD
	01	45	2	39C 60 K VS	69936640293	GOOD
	01	45	2	39C 80 K VS	69936667106	GOOD
	01	45	2	39C 120 K VS	69936675677	GOOD
225x5x60	01	45	2	38A 54 J VS	69936675859	GOOD
	01	45	2	SGB 60 H VX	69936640943	BETTER
225x20x51	01	35	2	3SG 60 H VXP	69936676452	BEST
	01	63	6	19A 54 J VS	69936623905	GOOD
230x10x32	01	35	2	38A 60 M VS	69936675929	GOOD
230x25x32	01	45	2	39C 80 K VS	69936639374	GOOD
250x10x32	01	35	5	86A 54 O VS	66253050139	GOOD
	01	63	6	38A 60 L VS3	69210431945	BETTER
	01	35	1	38A 60 M VS	69936675931	GOOD
250x13x32	01	63	6	86A 54 K VS	66253050123	GOOD
	01	63	6	86A 54 O VS	66253050128	GOOD
250x13x32	01	45	1	38A 60 L VS3	66253348353	BETTER
250x13x76,2	01	35	5	3SG 60 K VS	69936623734	BEST
250x20x32	01	35	5	38A 60 L VS3	69210431009	BETTER
	01	45	1	37C 60 K VK	69210432357	GOOD

BONDED  
ABRASIVES

SUPER  
ABRASIVES

DIAMOND  
TOOLS

CLEANING,  
POLISHING  
& MASKING

PERSONAL  
PROTECTION  
EQUIPMENT

TECHNICAL  
INFORMATION

Dimensions Key: DIM: Dimensions, D: Diameter, T: Thickness, H: Hole

MOS: Maximum Operating Speed,  
PK QTY: Packaging Quantity

## STRAIGHT WHEELS

DIM DxTxH (mm)	SHAPE	MOS (m/s)	PK QTY	SPECIFICATION	ART. NO.	BEST/ BETTER/ GOOD
<b>■ ■ ■ SHAPE 01</b>						
250x20x76,2	01	45	1	38A 60 L VS	69936675862	GOOD
250x25x32	01	45	1	38A 60 L VS	66253049927	GOOD
	01	35	5	37C 60 K VK	69210431029	GOOD
	01	35	5	37C 80 K VK	69210431030	GOOD
	01	35	5	38A 46 L VS3	69210431034	BETTER
	01	35	5	39C 60 K VK	69210431068	GOOD
	01	45	5	25A 60 L VS3	69210431151	BETTER
	01	45	1	38A 60 M VS	69936639356	GOOD
	01	35	5	39C 80 L VS	69936675679	GOOD
250x25x31,75	01	35	1	39C 60 K VS	69936623664	GOOD
250x32x32	01	45	1	SGB 60 K VX	66253050162	BETTER
	01	45	1	37C 60 K VK	69210431678	GOOD
	01	45	1	39C 60 K VS	69936639837	GOOD
	01	45	1	39C 80 K VS	69936640845	GOOD
300x32x32	01	35	3	37C 60 K VK	69210431016	GOOD

BONDED  
ABRASIVES

SUPER  
ABRASIVES

DIAMOND  
TOOLS

CLEANING,  
POLISHING  
& MASKING

PERSONAL  
PROTECTION  
EQUIPMENT

TECHNICAL  
INFORMATION

ART. NO. With **VITRIUM**  Revolutionary bond technology

## WHEELS RECESSED ONE SIDE

DIM DxTxH (mm)	P (mm)	F (mm)	SHAPE	MOS (m/s)	PK QTY	SPECIFICATION	ART. NO.	BEST/ BETTER/ GOOD
<b>SHAPE 05</b>								
180x20x31,75	100	6	05	35	2	3SG 60 G VSPF	69936639505	BEST
	100	6	05	35	2	3SG 60 J VS	69936639808	BEST
			05	45	2	38A 60 J VS	69936640226	GOOD
180x25x31,75	105	12	05	63	2	38A 60 K VS3	66253354035	BETTER
	105	13	05	50	2	38A 46 K VS3	66253354036	BETTER
	105	12	05	35	2	3SG 46 K VS	69936621519	BEST
	105	12	05	35	2	38A 60 L VS	69936621526	GOOD
	105	12	05	35	2	38A 46 J VS	69936621529	GOOD
	105	13	05	50	2	38A 60 J VS	69936621557	GOOD
	105	13	05	50	2	3SG 60 K VS	69936621570	BEST
			05	45	2	SGB 46 K VX	69936621605	BETTER
200x25x31,75			05	35	2	3SG 60 K VS	69936621575	BEST
			05	45	2	3SG 60 G VSPF	69936640304	BEST
200x40x20	110	25	05	35	2	19A 54 L VS	69936639603	GOOD
			05	45	2	39C 80 J VS	69936640285	GOOD

## STRAIGHT CUPS

DIM DxTxH (mm)	W (mm)	E (mm)	SHAPE	MOS (m/s)	PK QTY	SPECIFICATION	ART. NO.	BEST/ BETTER/ GOOD
<b>SHAPE 06</b>								
63x40x20	10	10	06	45	10	38A 60 J VS3	66253348322	BETTER
80x40x20	10	10	06	63	6	SGB 60 L VX	66253050098	BETTER
	8	8	06	63	6	38A 60 J VS3	66253348289	BETTER
	6	8	06	32	10	38A 60 L VS3	66253348323	BETTER
			06	45	10	SGB 60 L VX	69936641494	BETTER
80x40x32	10	10	06	35	5	38A 46 J VS3	66253348326	BETTER
100x40x20	8	10	06	32	4	38A 46 L VS3	69210431242	BETTER
	8	10	06	32	4	38A 80 L VS3	69210431245	BETTER
100x40x32	13	13	06	35	2	38A 60 K VS	69936674854	GOOD
100x50x20	10	13	06	45	2	3SG 60 L VX	66253049960	BEST
	10	10	06	45	2	3SG 60 K VX	66253049965	BEST
	10	13	06	45	2	3SG 80 L VX	66253049966	BEST
	10	10	06	45	2	3SG 60 J VX	66253050069	BEST
	10	13	06	45	2	38A 80 J VS3	66253348324	BETTER
	10	10	06	45	2	38A 60 J VS3	66253348327	BETTER
	10	10	06	45	2	38A 60 I VS3	66253348629	BETTER

**Dimensions Key:** DIM: Dimensions, D: Diameter, T: Thickness, H: Hole;  
P = Recess Diameter, F = Recess Depth, W = Rim Width, E = Back Thickness

MOS: Maximum Operating Speed,  
PK QTY: Packaging Quantity

BONDED  
ABRASIVES

SUPER  
ABRASIVES

DIAMOND  
TOOLS

CLEANING,  
POLISHING  
& MASKING

PERSONAL  
PROTECTION  
EQUIPMENT

TECHNICAL  
INFORMATION

## STRAIGHT CUPS

DIM DxTxH (mm)	W (mm)	E (mm)	SHAPE	MOS (m/s)	PK QTY	SPECIFICATION	ART. NO.	BEST/ BETTER/ GOOD
 SHAPE 06								
100x50x20			06	32	4	38A 120 I VS3	66253358793	BETTER
	10	10	06	32	2	38A 46 L VS3	69210431250	BETTER
			06	45	2	38A 80 L VS	69936639354	GOOD
	10	13	06	45	2	38A 60 L VS	69936639450	GOOD
	10	13	06	45	2	38A 60 M VS	69936639460	GOOD
	10	10	06	32	2	38A 80 J VS	69936639600	GOOD
			06	45	2	38A 100 K VS	69936639617	GOOD
	10	13	06	32	2	39C 80 J VS	69936640131	GOOD
			06	32	2	86A 80 M VS	69936640142	GOOD
			06	45	2	SGB 46 L VX	69936641536	BETTER
			06	45	2	SGB 60 L VX	69936676114	BETTER
100x50x32	10	10	06	45	2	3SG 60 K VX	66253050073	BEST
	10	10	06	45	2	38A 60 K VS	69936674859	GOOD
125x40x31,75			06	45	2	38A 46 J VS3	66253358794	BETTER
			06	32	2	38A 60 J VS3	66253358795	BETTER
			06	35	2	38A 60 K VS	69936623645	GOOD
125x50x20			06	45	2	38A 60 L VS	69936639451	GOOD
125x50x32	13	13	06	45	2	SGB 60 J VX	66253050075	BETTER
	10	13	06	45	2	38A 60 L VS	69936639992	GOOD
	10	8	06	45	2	38A 46 K VS	69936674867	GOOD
			06	50	4	SGB 46 K VX	69936678983	BETTER
125x60x32			06	45	2	38A 46 L VS	69936640218	GOOD
125x63x32	10	10	06	32	4	86A 46 E VXP	66253051528	GOOD
	8	13	06	32	2	38A 46 L VS3	69210431266	BETTER
	10	10	06	45	2	38A 60 L VS3	69210431699	BETTER
	10	13	06	45	2	SGB 60 K VX	69936640579	BETTER
	25	16	06		2	39C 60 J V	69936668305	GOOD
150x40x32	16	13	06	45	2	38A 46 H VS	69936674872	GOOD
	16	13	06	45	2	38A 60 K VS	69936674875	GOOD
150x50x32	16	16	06	45	2	3SG 46 K VX	66253050068	BEST
	16	16	06	45	2	SGB 60 K VX	66253050076	BETTER
			06	45	2	38A 46 L VS	69936639371	GOOD
	16	16	06	45	2	38A 60 K VS	69936674879	GOOD
150x50x65	20	15	06	32	2	38A 60 L VS	69936639480	GOOD
			06	32	2	39C 80 J VS	69936639798	GOOD
150x50x31,75			06	50	1	38A 46 J VS3	66253358789	BETTER
150x63x32	13	13	06	32	2	SGB 46 J VX	66253054727	BETTER
			06	45	2	38A 46 L VS	69936639880	GOOD
	16	16	06	32	2	38A 36 I VS	69936640369	GOOD
			06	45	2	38A 60 K VS	69936640370	GOOD
	16	16	06	45	2	38A 46 J VS	69936674881	GOOD
150x63x50,8	16	16	06	45	2	SGB 60 J VX	66253050082	BETTER

ART. NO. With **VITRIUM** Revolutionary bond technology



DIM DxTxH (mm)	W (mm)	E (mm)	SHAPE	MOS (m/s)	PK QTY	SPECIFICATION	ART. NO.	BEST/ BETTER/ GOOD
<b>SHAPE 06</b>								
150x80x32	10	16	06	45	2	38A 60 L VS3	69210433236	BETTER
	20	20	06	45	2	38A 46 H VS	69936674905	GOOD
	20	20	06	63	2	SGB 46 G VXP	69936676357	BETTER
175x75x76,2	20	20	06	45	2	SGB 46 G VXP	66253050097	BETTER
	20	20	06	32	1	38A 36 I VS	69936681747	GOOD
180x63x50,8	16	16	06	45	2	SGB 46 J VX	66253050084	BETTER
180x76x32	16	16	06	45	2	38A 36 I VS	69936639449	GOOD
	16	16	06	45	2	3SG 36 I VX	66253049962	BEST
	16	16	06	45	2	38A 36 I VS3	66253348321	BETTER
	16	16	06	45	2	38A 46 I VS	69936639533	GOOD
	16	16	06	32	2	38A 46 H VS	69936639616	GOOD
			06	45	2	32A 46 I VS	69936640090	GOOD
180x80x32	16	16	06	63	6	38A 46 H VS	69936674889	GOOD
200x40x32	45	15	06	45	2	38A 46 L VS	66243570536	GOOD
	45	15	06	45	2	38A 60 L VS	66243570537	GOOD
200x40x76,2	40	13	06	45	2	SGB 60 L VX	66253050087	BETTER
	40	13	06	45	2	39C 60 J V	69936668347	GOOD
	40	13	06	35	1	38A 46 M VS	69936674890	GOOD
200x63x50,8	20	20	06	45	2	38A 36 H VS	69936674896	GOOD
	20	20	06	45	2	38A 46 H VS	69936674898	GOOD
200x82x78	16	20	06	45	2	3SG 36 I VX	66253049964	BEST
	16	20	06	45	2	38A 36 H VS3	66253348319	BETTER
	16	20	06	45	2	38A 46 H VS3	66253348325	BETTER
			06	32	1	SGB 36 H VXP	69936679013	BETTER
200x100x51			06	45	1	38A 36 H VBE	69210438349	GOOD
300x63x127	40	20	06	35	3	39C 60 J V	69936668365	GOOD

**Dimensions Key:** DIM: Dimensions, D: Diameter, T: Thickness, H: Hole;  
W = Rim Width, E = Back Thickness

**MOS:** Maximum Operating Speed,  
**PK QTY:** Packaging Quantity

BONDED  
ABRASIVES

SUPER  
ABRASIVES

DIAMOND  
TOOLS

CLEANING,  
POLISHING  
& MASKING

PERSONAL  
PROTECTION  
EQUIPMENT

TECHNICAL  
INFORMATION

## TAPER CUPS

DIM DxTxH (mm)	W (mm)	E (mm)	SHAPE	MOS (m/s)	PK QTY	SPECIFICATION	ART. NO.	BEST/ BETTER/ GOOD
 <b>SHAPE 11</b>								
80x32x20	6	8	11	45	6	SGB 60 L VX	66253050137	BETTER
100x40x20	8	10	11	32	4	3SG 60 K VX	66253050110	BEST
	8	10	11	32	4	38A 46 L VS3	69210431233	BETTER
	8	10	11	45	2	38A 46 K VS3	69210431246	BETTER
	8	10	11	32	2	38A 60 K VS	69936686170	GOOD
			11	45	2	SGB 46 L VX	69936686734	BETTER
	8	10	11	32	2	38A 60 L VS	69936688495	GOOD
100x40x32	8	10	11	45	2	3SG 60 K VX	66253050114	BEST
	8	10	11	45	2	2NQ 46 J VS3	66253348633	BEST
	8	10	11	35	2	38A 60 K VS	69936686169	GOOD
100x40x31,75			11	35	2	38A 60 J VS3	66253358216	BETTER
			11	32	2	38A 46 J VS3	66253358217	BETTER
			11	32	2	3SG 46 K VS	69936624034	BEST
			11	32	2	3SG 54 K VS	69936624036	BEST
			11	32	2	3SG 60 K VS	69936624043	BEST
			11	45	2	38A 54 K VS	69936624609	GOOD
125x40x32	8	10	11	45	2	38A 80 L VS3	69210431282	BETTER
	8	10	11	45	2	SGB 46 J VX	69936682429	BETTER
	8	10	11	45	2	38A 46 K VS	69936686175	GOOD
	8	10	11	32	2	38A 60 K VS	69936686176	GOOD
	8	10	11	35	2	3SG 46 K VS	69936686641	BEST
125x40x31,75			11	35	2	38A 46 J VS3	66253358218	BETTER
			11	45	2	38A 60 J VS3	66253358219	BETTER
			11	45	2	38A 54 K VS	69936625578	GOOD
125x45x20			11	32	2	3SG 46 K VX	66253055954	BEST
			11	45	2	32A 46 K VS	69936682367	GOOD
	6	13	11	50	10	SGB 60 K VX	69936686736	BETTER
150x50x32	10	13	11	45	2	SGB 46 J VX	66253050133	BETTER
	10	13	11	32	2	SGB 60 K VX	66253050134	BETTER
	10	13	11	45	2	38A 60 K VS	69936682576	GOOD
	10	13	11	45	2	38A 46 K VS	69936686177	GOOD
100/80x40x31,75	6	13	11	32	2	38A 60 J VS3	66253348630	BETTER

BONDED  
ABRASIVES

SUPER  
ABRASIVES

DIAMOND  
TOOLS

CLEANING,  
POLISHING  
& MASKING

PERSONAL  
PROTECTION  
EQUIPMENT

TECHNICAL  
INFORMATION

ART. NO. With **VITRIUM**  Revolutionary bond technology

## DISHES

DIM DxTxH (mm)	W (mm)	E (mm)	J (mm)	K (mm)	U (mm)	SHAPE	MOS (m/s)	PK QTY	SPECIFICATION	ART. NO.	BEST/ BETTER/ GOOD
<b>SHAPE 12</b>											
80x10x13	4	6	35	35	2,5	12	35	50	38A 60 K VS3	66253348375	BETTER
100x13x20	5	7	45	50	2,5	12	45	2	3SG 60 K VX	66253050236	BEST
	5	7	41	41	3,2	12	35	2	38A 60 J VS3	66253348382	BETTER
						12	45	2	3SG 60 L VS	69936682502	BEST
125x13x20	6	7	61	61	3,2	12	45	2	2NQ 60 J VS3	66253348378	BEST
	6	7	61	61	3,2	12	33	5	38A 60 J VS3	66253348488	BETTER
	6	7	61	61	3,2	12	45	2	3SG 60 J VX	69936686768	BEST
125x13x32	6	6	61	61	3,2	12	45	5	38A 60 L VS3	69210432313	BETTER
	6	6	61	61	3,2	12	45	2	38A 80 K VS3	69210433194	BETTER
150x13x20	7	9	86	86	3,2	12	45	2	3SG 60 L VX	66253050231	BEST
	8	9	56	56	3,2	12	45	2	SGB 60 K VS3	66253348379	BEST
	8	9	56	56	3,2	12	35	2	SGB 46 K VS3	66253348384	BEST
150x13x32	7	9	86	86	3,2	12	45	2	3SG 46 K VX	66253050238	BEST
	7	9	86	86	3,2	12	45	2	3SG 60 K VX	66253050239	BEST
	7	9	86	86	3,2	12	35	4	38A 60 J VS3	66253348380	BETTER
	7	9	86	86	3,2	12	63	2	38A 46 K VS	69936686194	GOOD
150x13x31,75						12	35	5	3SG 60 K VS	69936624608	BEST
150x16x20						12	45	2	SGB 60 L VX	69936686710	BETTER
150x16x32	8	9	66	66	3,2	12	45	5	38A 60 L VS3	69210431439	BETTER
	8	9	66	66	3,2	12	35	4	38A 46 L VS3	69210431834	BETTER
150x20x32	8	11	87	87	3,2	12	45	2	SGB 60 K VX	66253050245	BETTER
175x18x32	9	8	90	90	3,2	12	45	5	38A 60 K VS3	69210431517	BETTER
	9	8	90	90	3,2	12	35	5	38A 60 L VS3	69210431859	BETTER
200x20x32	10	12	90	90	3,2	12	35	5	38A 46 L VS3	69210431518	BETTER
	10	12	90	90	3,2	12	45	2	38A 60 K VS	69936686215	GOOD
250x25x32	11	12	100	100	3,2	12	35	5	38A 46 L VS3	69210431432	BETTER

**Dimensions Key:** DIM: Dimensions, D: Diameter, T: Thickness, H: Hole, W: Rim Width; E: Back Thickness, J: External Flat Diameter, K: Internal Flat Diameter, U: Rim Depth

**MOS:** Maximum Operating Speed, **PK QTY:** Packaging Quantity

BONDED  
ABRASIVES

SUPER  
ABRASIVES

DIAMOND  
TOOLS

CLEANING,  
POLISHING  
& MASKING

PERSONAL  
PROTECTION  
EQUIPMENT

TECHNICAL  
INFORMATION

# SAW SHARPENING

Manufactured using Norton's market leading technologies, our vitrified saw sharpening wheels are designed to ensure better grinding performance.

Using premium quality abrasives and bonds, our products are intended to lower overall manufacturing and regrinding costs in all forestry and saw markets.

For Saw Sharpening, please take note of the safety instructions, about the storage and use of grinding wheels, available on page 564.



See a small selection of our new range of Saw Sharpening wheels with the revolutionary bond below

	STEELS						
	CHROME PLATE	HIGH SPEED STEEL	INOX	STEEL - SOFT (UP TO 45RC)	STEEL HARDENED (OVER 56RC)	STEEL HIGH CARBON / HIGH CHROME CONTENT	STELLITE
NQ	X	X	X	X	X	X	X
SG / GF		X		X	X		
19A / 57A				X			
25A / 86A / 32A				X	X		
38A	X	X		X	X	X	X
39C			X				

## EXAMPLE OF SPECIFICATIONS

MATERIAL	TYPE OF TOOTH	OPERATION	RESIN	WHEEL GRADE	REFERENCE	RECOMMEND. SPEC
High quality steel	Large	All	None	Soft	MTVS	19A 60 MVS MTVS
Standard quality steel	Small	All	None	Hard	MDVS	19A 60 OVS MDVS
Standard quality steel	Double cut	Finishing	1mm resin coated on one side	Soft	T6	38A 60 MVS T6
Treated steel	Swage	Roughing		Medium	M6	86A 54 KVS M6
		Finishing		Soft	T6	38A 60 MVS T6
Stellite tipped	Stellite tipped	Finishing		Soft	T6	38A 60 MVS T6
		Roughing		Medium	M6	86A 54 KVS M6
		Truing	Hard	D6	86A 54 OVS D6	

BONDED ABRASIVES

SUPER ABRASIVES

DIAMOND TOOLS

CLEANING, POLISHING & MASKING

PERSONAL PROTECTION EQUIPMENT

TECHNICAL INFORMATION

## NORTON QUANTUM WITH VITRIUM<sup>3</sup> 5NQ

BEST +++++

INNOVATION

### REVOLUTIONARY BOND TECHNOLOGY

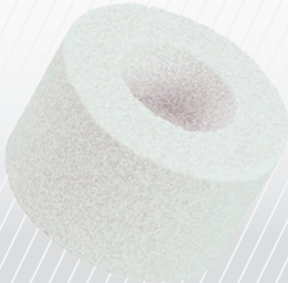

#### FEATURES

- Engineered ceramic grain shape and chemistry with new revolutionary bond
- Perfect combination of sharpness and toughness

#### BENEFITS

- Extreme versatility for all precision applications
- Reduced dressing frequency and cost
- High profile accuracy
- Cooler cut and high speed material removal

## NORTON QUANTUM 3NQ / 2NQ

BEST +++++



#### FEATURES

- Engineered ceramic grain shape and chemistry with new bond technology
- A perfect blend between sharpness (free cutting) and toughness (life)

#### BENEFITS

- Versatile in all low, medium and high force applications
- 30% to 100% higher metal removal rate
- >15% lower threshold power

## SG 3SG

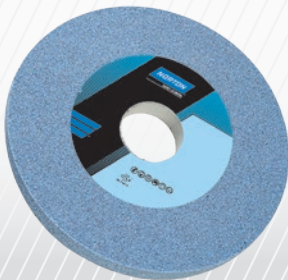

#### FEATURES

- High concentration of SG ceramic aluminum oxide abrasive
- Unique, self sharpening, microcrystalline structure

#### BENEFITS

- Very good cutting capability
- High removal rate & extended wheel life
- Suitable for very hard steels

BONDED  
ABRASIVES

SUPER  
ABRASIVES

DIAMOND  
TOOLS

CLEANING,  
POLISHING  
& MASKING

PERSONAL  
PROTECTION  
EQUIPMENT

TECHNICAL  
INFORMATION



## 38A WITH VITRIUM<sup>3</sup>

BETTER ++++

REVOLUTIONARY BOND TECHNOLOGY

VITRIUM 



### FEATURES

- High purity white aluminium oxide abrasives with enhanced bond adhesion
- High friability abrasive

### BENEFITS

- Even cooler & burn free cutting
- Extended wheel life
- Improved profile accuracy
- Ideal for heat sensitive applications with light to moderate feed rates

## SG SGB



### FEATURES

- Medium concentration of SG ceramic aluminum oxide
- Harder & sharper than conventional abrasive grains

### BENEFITS

- Good cutting capability
- Suitable for low to medium power machines
- Very versatile on a wide variety of steels

## 38A

GOOD +++



### FEATURES

- High purity white aluminium oxide abrasive
- Friable

### BENEFITS

- Cool & burn free cutting
- Ideal for heat-sensitive applications with light to moderate feed rates

## 86A



### FEATURES

- Highly refined pink aluminium oxide abrasive
- Tougher abrasive than pure white aluminium oxide
- Contains a small portion of chromium oxide

### BENEFITS

- Very versatile
- Reduced dress frequency

## 19A



### FEATURES

- A blend of A & 38A abrasives
- Primarily used in saw grinding applications

### BENEFITS

- Very versatile. For use on a wide variety of steels
- Good yield, good removal rate
- Good balance between cut rate & form holding ability

## 39C

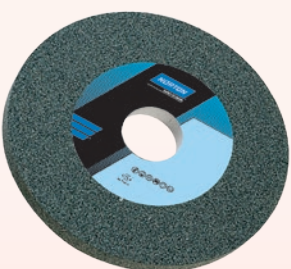

### FEATURES

- Highest purity green silicon carbide abrasive
- Harder & more friable than aluminium oxide abrasive

### BENEFITS

- Ideal for precision grinding & sharpening applications on metal carbide

BONDED ABRASIVES

SUPER ABRASIVES



DIAMOND TOOLS

CLEANING, POLISHING & MASKING

PERSONAL PROTECTION EQUIPMENT

TECHNICAL INFORMATION

# STRAIGHT WHEELS

DIM DxTxH (mm)	SHAPE	MOS (m/s)	PK QTY	SPECIFICATION	ART. NO.	BEST/ BETTER/ GOOD
	 SHAPE 01	 SHAPE 01C				
125x6x32	01	35	5	38A 60 L VS	66253050440	GOOD
125x8x20	01	33	5	38A 60 L VS3	69210431218	BETTER
150x3x30	01	35	10	38A 80 L VS3	66243541074	BETTER
150x3x32	01	35	10	38A 80 L VS3	66243541080	BETTER
150x3,2x32	01	45	2	19A 60 M VS	69936675941	GOOD
150x4x20	01	35	10	38A 80 L VS3	66243541077	BETTER
	01	45	2	38A 100 M VS	69936640219	GOOD
	01	45	2	38A 60 L VS	69936675591	GOOD
	01	45	2	38A 80 N VS	69936676720	GOOD
150x4x30	01	45	2	38A 80 N VS	69936639730	GOOD
150x4x32	01	35	10	SGB 80 K VS3	66243541066	BETTER
	01	35	10	38A 80 L VS3	66243541079	BETTER
	01	63	2	19A 60 M VS	69936674920	GOOD
	01	35	2	19A 60 O VS	69936675946	GOOD
150x6x20	01	45	2	86A 80 O VS	69936686760	GOOD
150x6x32	01	45	10	SGB 80 K VS3	66243541083	BETTER
	01	35	10	SGB 60 K VS3	66243541070	BETTER
	01	45	2	3SG 80 L VX	66253054873	BEST
	01	45	2	3SG 60 L VX	66253055040	BEST
	01	35	2	39C 120 K VS	69936675617	GOOD
	01	63	2	38A 60 L VS	69936675741	GOOD
	01	35	2	19A 60 M VS	69936675964	GOOD
150x6x38	01	35	10	SGB 60 K VS3	66243541082	BETTER
150x8x20	01	35	5	38A 60 L VS3	69210431422	BETTER
	01	45	2	86A 80 O VS	69936686743	GOOD
150x8x32	01	45	2	3SG 60 J VX	66253055041	BEST
	01	45	10	38A 60 L VS3	66243541068	BETTER
	01	45	2	38A 60 L VS	69936675743	GOOD
	01	35	5	38A 120 J VS	69936675748	GOOD
150x10x20	01	35	5	38A 60 L VS3	69210431426	BETTER
150x10x32	01	45	10	38A 60 L VS3	66243541071	BETTER
	01	45	10	SGB 60 K VS3	66243541072	BETTER
	01	45	2	19A 60 O VS	66253050201	GOOD
	01	45	2	38A 120 J VS	69936675749	GOOD
150x13x32	01	45	2	38A 60 N VS	69936675758	GOOD
	01	45	2	38A 120 J VS	69936675760	GOOD
175x3x51	01	35	10	38A 60 L VS3	66243541075	BETTER
175x4x51	01	45	5	19A 60 M VS	66253052709	GOOD
175x6x51	01	35	10	38A 60 L VS3	66243541069	BETTER
180x6x32	01	35	2	38A 60 L VS	69936675784	GOOD
180x10x32	01	45	2	38A 80 J VS	69936675781	GOOD
180x13x32	01	45	2	3SG 120 J VX	66253054874	BEST
	01	35	2	3SG 80 J VX	66253054892	BEST
	01	45	2	3NQ 60 I VS3	66253348361	BEST
	01	45	2	2NQ 46 I VS3	66253348363	BEST
	01	35	2	SGB 60 J VX	69936639148	BETTER
	01	45	2	38A 60 J VS	69936675794	GOOD
	01	45	2	38A 60 L VS	69936675797	GOOD
	01	45	2	38A 80 L VS	69936675801	GOOD
	01	45	2	38A 120 J VS	69936675802	GOOD

ART. NO. With **VITRIUM** Revolutionary bond technology

## STRAIGHT WHEELS

DIM DxTxH (mm)	SHAPE	MOS (m/s)	PK QTY	SPECIFICATION	ART. NO.	BEST/ BETTER/ GOOD
	SHAPE 01	SHAPE 01C				
200x1,5x32	01	63	10	SGB 80 K VS3	66253354585	BETTER
200x2x32	01	35	10	38A 80 L VS3	66243541085	BETTER
	01	63	10	SGB 80 K VS3	66253354586	BETTER
200x2,5x32	01	63	10	SGB 80 K VS3	66253354587	BETTER
200x3x32	01	35	10	38A 80 L VS3	66243541084	BETTER
	01	63	10	SGB 80 K VS3	66253354588	BETTER
200x4x32	01	35	10	SGB 80 K VS3	66243541087	BETTER
	01	45	2	19A 60 O VS	69936675986	GOOD
200x6x20	01	35	10	38A 60 L VS3	66243541081	BETTER
200x6x32	01	35	10	38A 60 K VS3	66243541076	BETTER
	01	35	10	SGB 60 K VS3	66243541086	BETTER
	01	45	2	38A 60 M VS	66253050455	GOOD
	01	45	2	38A 80 N VS	69936639662	GOOD
	01	45	2	19A 60 M VS	69936675988	GOOD
	01	35	2	SGB 120 J VX	69936677029	BETTER
200x8x20	01	35	10	38A 60 L VS3	66243541090	BETTER
200x8x32	01C	35	5	38A 60 L VS3	69210431430	BETTER
	01	35	10	SGB 60 K VS3	66243541088	BETTER
	01	35	5	38A 60 L VS3	69210431430	BETTER
	01	63	6	38A 60 M VS	69936658078	GOOD
	01	63	6	19A 60 M VS	69936675990	GOOD
200x10x20	01	35	10	38A 60 L VS3	66243541091	BETTER
200x10x32	01	63	2	86A 54 O VS	66253050147	GOOD
	01	35	5	38A 60 L VS3	66253348277	BETTER
	01	45	2	SGB 60 J VX	69936639157	BETTER
	01	35	2	SGB 80 J VX	69936639158	BETTER
	01	45	2	38A 60 L VS	69936675818	GOOD
	01	35	2	38A 120 J VS	69936675819	GOOD
200x13x32	01	63	10	38A 60 L VS3	66253348352	BETTER
	01	45	2	SGB 60 J VX	69936639160	BETTER
	01	45	2	38A 60 J VS	69936675821	GOOD
	01	45	2	38A 60 L VS	69936675823	GOOD
	01	50	2	SGB 120 J VX	69936676608	BETTER
200x16x32	01	35	2	38A 60 L VS	69936675825	GOOD
200x16x76,2	01	35	4	38A 60 L VS	69936675827	GOOD
225x5x60	01	45	2	38A 54 J VS	69936675859	GOOD
230x10x32	01	35	2	38A 60 M VS	69936675929	GOOD
250x3x32	01	35	10	SGB 80 K VS3	66243541097	BETTER
250x10x20	01	50	10	38A 60 L VS3	66243541093	BETTER
250x10x32	01C	35	5	38A 60 L VS3	69210431945	BETTER
	01	35	5	86A 54 O VS	66253050139	GOOD
	01	35	1	38A 60 M VS	69936675931	GOOD
250x13x32	01	63	10	38A 60 L VS3	66253348353	BETTER
	01	63	6	86A 54 K VS	66253050123	GOOD
	01	63	6	86A 54 O VS	66253050128	GOOD

Dimensions Key: DIM: Dimensions, D: Diameter, T: Thickness, H: Hole

MOS: Maximum Operating Speed,  
PK QTY: Packaging Quantity

BONDED  
ABRASIVES

SUPER  
ABRASIVES

DIAMOND  
TOOLS

CLEANING,  
POLISHING  
& MASKING

PERSONAL  
PROTECTION  
EQUIPMENT

TECHNICAL  
INFORMATION

# SURFACE GRINDING

Norton offers a wide range of straight wheels, straight recessed wheels, cylinders and segments with the most innovative abrasives and bonds, ensuring maximum performance, high productivity and extreme versatility for all your surface grinding applications.

For Surface Grinding, please take note of the safety instructions, about the storage and use of grinding wheels, available on page 564.

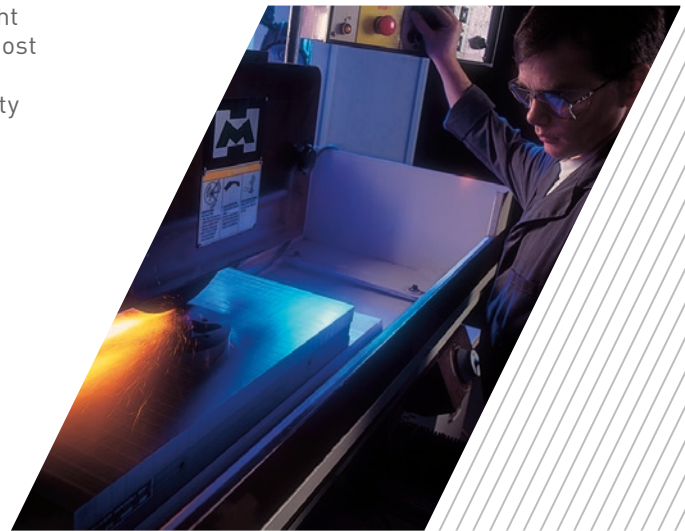

BONDED ABRASIVES

SUPER ABRASIVES

DIAMOND TOOLS

CLEANING, POLISHING & MASKING

PERSONAL PROTECTION EQUIPMENT

TECHNICAL INFORMATION

	STEELS									NON-FERROUS METALS			CERAMICS			POLYMERS	
	AEROSPACE ALLOYS: NIMONIC, INCONEL, HASTALLOY	CAST IRON	CHROME PLATE	HIGH SPEED STEEL	INOX	STEEL - SOFT (UP TO 45RC)	STEEL HARDENED (OVER 56RC)	STEEL-HIGH CARBON / HIGH CHROME CONTENT	STELLITE	ALUMINIUM	TITANIUM	TUNGSTEN CARBIDE	CERAMIC (FIRED)	CERAMIC (GREEN)	METAL SPRAY	PLASTICS	RUBBER
NQ	X	X	X	X	X	X	X	X	X							X	
SG / GF	X	X		X		X	X										
IPA	X						X								X	X	
19A / 57A						X											
25A / 86A / 32A						X	X										
37C		X							X						X	X	
38A	X	X	X	X		X	X	X	X				X				
39C					X					X	X	X	X	X			

## NORTON QUANTUM WITH VITRIUM<sup>3</sup> 5NQ

BEST +++++

INNOVATION

### REVOLUTIONARY BOND TECHNOLOGY

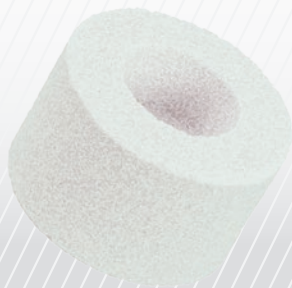

#### FEATURES

- Engineered ceramic grain shape and chemistry with new revolutionary bond
- Perfect combination of sharpness and toughness

#### BENEFITS

- Extreme versatility for all precision applications
- Reduced dressing frequency and cost
- High profile accuracy
- Cooler cut and high speed material removal



## NORTON QUANTUM 5NQ / 3NQ / 2NQ

BEST +++++



### FEATURES

- Engineered ceramic grain shape and chemistry with new bond technology
- A perfect blend between sharpness (free cutting) and toughness (life)

### BENEFITS

- Versatile in all low, medium and high force applications
- 30% to 100% higher metal removal rate
- >15% lower threshold power

## SG 5SG

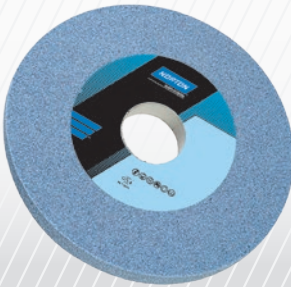

### FEATURES

- Very high concentration of SG ceramic aluminium oxide abrasive

### BENEFITS

- Ultimate cutting capability
- High removal rate & extended wheel life
- Perfect for technical applications where grinding parameters can be adjusted to optimise performance

## SG 3SG

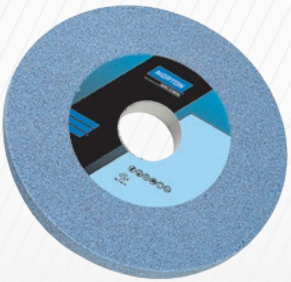

### FEATURES

- High concentration of SG ceramic aluminum oxide abrasive
- Unique, self sharpening, microcrystalline structure

### BENEFITS

- Very good cutting capability
- High removal rate & extended wheel life
- Suitable for very hard steels

BONDED  
ABRASIVES

SUPER  
ABRASIVES

DIAMOND  
TOOLS

CLEANING,  
POLISHING  
& MASKING

PERSONAL  
PROTECTION  
EQUIPMENT

TECHNICAL  
INFORMATION

## 38A WITH VITRIUM<sup>3</sup>

BETTER ++++

### REVOLUTIONARY BOND TECHNOLOGY

VITRIUM<sup>3</sup>



#### FEATURES

- High purity white aluminium oxide abrasives with enhanced bond adhesion
- High friability abrasive

#### BENEFITS

- Even Cooler & burn free cutting
- Extended wheel life
- Improved profile accuracy
- Ideal for heat sensitive applications with light to moderate feed rates



LINK TO WEBSITE  
AND ANIMATION

## SG SGA / SGB



#### FEATURES

- Medium concentration of SG ceramic aluminum oxide
- Harder & sharper than conventional abrasive grains

#### BENEFITS

- Good cutting capability
- Suitable for low to medium power machines
- Very versatile on a wide variety of steels

## VORTEX IPA



### FEATURES

- High performance engineered alumina grain
- High porosity & permeability for maximum coolant diffusion
- Optimal grain spacing for improved chip clearance & reduced friction



### BENEFITS

- Very high metal removal rates, resulting in reduced cycle times
- Improved part quality thanks to reduced heat generation
- Increase wheel life
- Consistent grinding performance
- Extremely cool cutting action promoting burn free results

## 38A

**GOOD +++**



### FEATURES

- High purity white aluminium oxide abrasive
- Friable

### BENEFITS

- Cool & burn free cutting
- Ideal for heat-sensitive applications with light to moderate feed rates

## 86A



### FEATURES

- Highly refined pink aluminium oxide abrasive
- Tougher abrasive than pure white aluminium oxide
- Contains a small portion of chromium oxide

### BENEFITS

- Very versatile
- Reduced dress frequency

BONDED ABRASIVES

SUPER ABRASIVES

DIAMOND TOOLS

CLEANING, POLISHING & MASKING

PERSONAL PROTECTION EQUIPMENT

TECHNICAL INFORMATION

## 19A



### FEATURES

- A blend of A & 38A abrasives
- Primarily used in saw grinding applications

### BENEFITS

- Very versatile. For use on a wide variety of steels
- Good yield, good removal rate
- Good balance between cut rate & form holding ability

## 39C

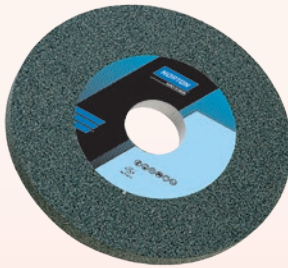

### FEATURES

- Highest purity green silicon carbide abrasive
- Harder & more friable than aluminium oxide abrasive

### BENEFITS

- Ideal for precision grinding & sharpening applications on metal carbide

## 37C



### FEATURES

- High purity black silicon carbide abrasive
- Harder & more friable than aluminum oxide abrasive

### BENEFITS

- Suitable for roughing operations in coarse grit & resinoid wheels
- Ideal for grinding & sharpening applications on metal carbide & non-ferrous metals



## STRAIGHT WHEELS

DIM DxTxH (mm)	SHAPE	MOS (m/s)	PK QTY	SPECIFICATION	ART. NO.	BEST/ BETTER/ GOOD
<b>SHAPE 01</b>						
180x16x32	01	35	2	3SG 60 H VXP	69936677179	BEST
180x20x32	01	45	2	3SG 60 H VXP	66243593654	BEST
	01	45	2	SGB 46 H VXP	69936638723	BETTER
200x16x76,2	01	35	4	38A 60 L VS	69936675827	GOOD
200x20x50	01	35	2	3SG 60 J VX	66253050362	BEST
	01	35	2	38A 60 J VS	69936639462	GOOD
	01	45	2	38A 46 K VS	69936641104	GOOD
	01	45	2	3SG 54 E VXP	69936676704	BEST
200x20x51	01	45	2	SGB 60 J VX	69936639251	BETTER
	01	35	2	39C 60 K VS	69936640176	GOOD
200x20x76	01	35	2	3SG 60 I VS	69936639744	BEST
	01	35	2	38A 60 I VS	69936639978	GOOD
	01	50	2	38A 46 K VS	69936641077	GOOD
200x20x50,8	01	45	2	3SG 60 H VXP	66243593696	BEST
	01	45	2	38A 60 K VS	66253049967	GOOD
	01	50	2	3SG 46 I VXP	66253052711	BEST
	01	45	2	3SG 46 K VS	69936623654	BEST
	01	45	2	38A 46 J VS	69936675832	GOOD
	01	35	2	38A 60 H VS	69936675834	GOOD
	01	45	2	3SG 46 J VS	69936676018	BEST
200x20x76,2	01	45	2	3SG 46 H VX	66253050156	BEST
200x25x51	01	45	2	38A 46 K VS	66253051086	GOOD
	01	50	2	38A 60 L VS	69936640125	GOOD
200x25x76,2	01	45	2	39C 60 K VS	69936675672	GOOD
	01	45	2	39C 80 L VS	69936675673	GOOD
	01	45	2	39C 120 K VS	69936675674	GOOD
	01	35	2	38A 46 L VS	69936675842	GOOD
	01	45	2	38A 60 L VS	69936675845	GOOD
200x32x51	01	45	2	38A 60 L VS	69936640245	GOOD
200x32x76,2	01	45	2	39C 80 K VS	69936675644	GOOD
225x20x51	01	45	2	SGB 60 H VX	69936640943	BETTER
	01	35	2	3SG 60 H VXP	69936676452	BEST
225x32x76,2	01	40	2	3SG 46 H VX	66253055043	BEST
230x25x50,8	01	35	5	38A 60 H VS	69936639829	GOOD
250x20x32	01	35	5	38A 60 L VS3	69210431009	BETTER
	01	45	1	37C 60 K VK	69210432357	GOOD
250x20x76,2	01	45	1	38A 60 L VS	69936675862	GOOD

BONDED  
ABRASIVES

SUPER  
ABRASIVES

DIAMOND  
TOOLS

CLEANING,  
POLISHING  
& MASKING

PERSONAL  
PROTECTION  
EQUIPMENT

TECHNICAL  
INFORMATION

Dimensions Key: DIM: Dimensions, D: Diameter, T: Thickness, H: Hole

MOS: Maximum Operating Speed,  
PK QTY: Packaging Quantity



## STRAIGHT WHEELS

DIM DxTxH (mm)	SHAPE	MOS (m/s)	PK QTY	SPECIFICATION	ART. NO.	BEST/ BETTER/ GOOD
 SHAPE 01						
250x25x32	01	45	1	38A 60 L VS	66253049927	GOOD
	01	35	5	37C 60 K VK	69210431029	GOOD
	01	35	5	37C 80 K VK	69210431030	GOOD
	01	35	5	38A 46 L VS3	69210431034	BETTER
	01	35	5	39C 60 K VK	69210431068	GOOD
	01	45	5	25A 60 L VS3	69210431151	BETTER
	01	45	1	38A 60 M VS	69936639356	GOOD
	01	35	5	39C 80 L VS	69936675679	GOOD
250x25x51	01	35	1	38A 60 L VS3	69210431048	BETTER
250x25x76	01	35	2	2NQ 60 G VS3	66253348365	BEST
	01	35	2	32A 46 I VS	69936639849	GOOD
	01	35	1	32A 60 I VS	69936639898	GOOD
250x25x31,75	01	35	1	39C 60 K VS	69936623664	GOOD
250x25x76,2	01	45	1	SGA 46 K VX	61463693965	BETTER
	01	45	1	38A 60 I VS	66253050101	GOOD
	01	45	1	SGB 46 K VX	66253050124	BETTER
	01	45	1	SGB 60 K VX	66253050126	BETTER
	01	45	1	3SG 60 K VX	66253055045	BEST
	01	63	2	2NQ 46 G VS3	66253348371	BEST
	01	63	2	38A 60 K VS3	66253354040	BETTER
	01	45	1	38A 46 K VS3	66253354041	BETTER
	01	45	1	38A 80 L VS	69936623651	GOOD
	01	45	1	3SG 46 K VS	69936623668	BEST
	01	35	1	SGB 70 H VXP	69936623901	BETTER
	01	35	1	38A 46 H VS	69936675867	GOOD
	01	45	1	3SG 60 L VS	69936675958	BEST
	01	45	3	3SG 54 F VXP	69936676054	BEST
250x32x32	01	45	1	SGB 60 K VX	66253050162	BETTER
	01	45	1	37C 60 K VK	69210431678	GOOD
250x32x32	01	45	1	39C 60 K VS	69936639837	GOOD
	01	45	1	39C 80 K VS	69936640845	GOOD
	01	35	3	38A 46 L VS3	69210431001	BETTER
250x32x76	01	35	1	38A 60 L VS3	69210431863	BETTER
	01	35	1	38A 60 L VS3	69210431863	BETTER
250x32x76,2	01	45	1	3SG 46 H VX	66253055046	BEST
250x40x51	01	35	3	37C 60 K VK	69210431004	GOOD
	01	35	3	38A 60 L VS3	69210431658	BETTER
250x40x76	01	35	3	38A 60 L VS3	69210431657	BETTER
	01	45	1	38A 46 L VS3	69210432025	BETTER
250x40x76,2	01	45	1	3SG 46 I VX	66253050259	BEST
	01	45	1	3SG 46 G VXP	69936676056	BEST

ART. NO. With **VITRIUM** Revolutionary bond technology

DIM DxTxH (mm)	SHAPE	MOS (m/s)	PK QTY	SPECIFICATION	ART. NO.	BEST/ BETTER/ GOOD
<b>SHAPE 01</b>						
300x25x127	01	50	1	SGA 60 K VX	61463693967	BETTER
	01	50	1	SGA 80 L VX	61463693973	BETTER
	01	45	1	SGA 46 K VS	61463699584	BETTER
	01	45	1	38A 60 K VS	66253050105	GOOD
	01	45	1	SGB 80 I VXP	66253050121	BETTER
	01	45	1	SGB 60 K VX	66253050132	BETTER
	01	45	1	3SG 46 K VX	66253055050	BEST
	01	45	1	3NQ 60 K VQN	66253262040	BEST
	01	63	2	2NQ 60 J VS3	66253348372	BEST
	01	63	2	38A 60 K VS3	66253354042	BETTER
	01	45	1	38A 46 K VS3	66253354043	BETTER
	01	35	1	38A 80 L VS	69936623648	GOOD
	01	45	1	38A 46 J VS	69936623662	GOOD
	01	50	1	39C 60 K VS	69936623687	GOOD
	01	45	1	19A 60 M VS	69936623719	GOOD
	01	35	1	39C 80 J VS	69936640343	GOOD
	01	45	1	39C 120 K VS	69936675646	GOOD
	01	35	1	3SG 60 H VXP	69936677184	BEST
300x32x32	01	45	1	38A 60 K VS	66253051100	GOOD
	01	35	3	37C 60 K VK	69210431016	GOOD
	01	35	3	39C 60 K VK	69210431036	GOOD
	01	45	1	25A 60 L VS3	69210431139	BETTER
300x32x127	01	45	1	3SG 60 K VX	66253055872	BEST
300x32x127	01	45	1	38A 46 H VS	69936675883	GOOD
	01	45	1	38A 60 L VS	69936675884	GOOD
	01	45	1	SGB 60 K VX	69936676386	BETTER
	01	35	1	SGB 46 F VXP	69936676705	BETTER
	01	35	1	GF 46 I VX	69936679795	GOOD
300x32x76,2	01	45	1	38A 46 H VS	69936675880	GOOD
300x40x32	01	45	1	39C 60 K VS	69936639362	GOOD
	01	35	3	39C 80 K VS	69936676387	GOOD
300x40x51	01	35	3	37C 60 K VK	69210431057	GOOD
	01	35	3	38A 60 L VS3	69210431059	BETTER
300x40x76	01	35	1	38A 60 K VS	66253049953	GOOD

BONDED  
ABRASIVES

SUPER  
ABRASIVES

DIAMOND  
TOOLS

CLEANING,  
POLISHING  
& MASKING

PERSONAL  
PROTECTION  
EQUIPMENT

TECHNICAL  
INFORMATION

Dimensions Key: DIM: Dimensions, D: Diameter, T: Thickness, H: Hole

MOS: Maximum Operating Speed,  
PK QTY: Packaging Quantity

## STRAIGHT WHEELS

DIM DxTxH (mm)	SHAPE	MOS (m/s)	PK QTY	SPECIFICATION	ART. NO.	BEST/ BETTER/ GOOD
<b>SHAPE 01</b>						
300x40x127	01	45	1	SGB 60 K VX	66253050179	BETTER
	01	45	1	3SG 60 K VX	66253055053	BEST
	01	45	1	3SG 46 H VX	66253055893	BEST
	01	35	1	37C 60 K VK	69210431073	GOOD
	01	45	1	SGB 46 G VXP	69936639946	BETTER
	01	45	1	39C 80 K VS	69936675649	GOOD
	01	35	1	39C 60 K VS	69936675684	GOOD
	01	35	1	38A 46 H VS	69936675888	GOOD
	01	35	1	38A 60 L VS	69936675891	GOOD
	01	35	1	GF 60 K VX	69936680686	GOOD
300x40x31,75	01	35	1	39C 60 L VS	69936623682	GOOD
300x40x76,2	01	45	1	IPA 60 H VTX	66253049863	BETTER
300x50x127	01	45	1	SGB 46 G VXP	66243570384	BETTER
	01	35	1	38A 46 J VS	69936623649	GOOD
350x40x51	01	35	3	37C 60 K VK	69210431101	GOOD
	01	32	1	38A 60 L VS3	69210432052	BETTER
350x40x127	01	35	3	37C 60 K VK	69210431889	GOOD
350x40x127	01	35	3	37C 60 J VK	69210432038	GOOD
	01	35	1	39C 60 K VK	69210432040	GOOD
350x50x127	01	45	1	SGB 46 H VXP	66253054500	BETTER
	01	35	2	38A 80 L VS3	69210431072	BETTER
	01	35	1	37C 60 K VK	69210431686	GOOD
350x63x127	01	35	1	38A 46 L VS3	69210431074	BETTER
	01	50	1	38A 60 L VS3	69210431076	BETTER
355x25x127	01	45	1	SGA 46 J VS	61463699586	BETTER
	01	45	1	SGB 60 L VX	66253050135	BETTER
	01	50	1	3SG 60 L VX	66253055895	BEST
355x25x127	01	45	1	3SG 60 K VS	69936623716	BEST
	01	45	1	38A 60 L VS	69936675901	GOOD
355x32x127	01	35	1	2NQ 60 J VS3	66253348373	BEST
	01	35	1	3SG 80 K VS	69936638294	BEST
	01	35	1	38A 60 M VS	69936639074	GOOD
	01	45	1	38A 60 L VS	69936675903	GOOD
	01	50	1	SGB 54 E VXP	69936676713	BETTER

BONDED  
ABRASIVES

SUPER  
ABRASIVES

DIAMOND  
TOOLS

CLEANING,  
POLISHING  
& MASKING

PERSONAL  
PROTECTION  
EQUIPMENT

TECHNICAL  
INFORMATION

ART. NO. With **VITRIUM** Revolutionary bond technology

DIM DxTxH (mm)	SHAPE	MOS (m/s)	PK QTY	SPECIFICATION	ART. NO.	BEST/ BETTER/ GOOD
<b>SHAPE 01</b>						
355x40x127	01	45	1	SGA 80 I VXP	61463699589	BETTER
	01	45	1	IPA 60 H VTX	66253049877	BETTER
	01	45	1	SGB 46 G VXP	66253049901	BETTER
	01	45	1	SGB 46 J VX	66253050117	BETTER
	01	45	1	3SG 60 L VX	66253055057	BEST
	01	50	1	2NQ 46 G VS3	66253348367	BEST
	01	45	1	3SG 60 K VS	69936623611	BEST
	01	35	1	38A 46 J VS	69936623753	GOOD
	01	35	1	39C 60 K VS	69936675685	GOOD
	01	45	1	38A 46 H VS	69936675906	GOOD
	01	35	1	38A 60 L VS	69936675908	GOOD
355x50x127	01	45	1	SGB 54 G VXP	66253049857	BETTER
	01	45	1	IPA 60 H VTX	66253049880	BETTER
	01	45	1	IPA 60 H VTX	66253049883	BETTER
	01	45	1	38A 60 K VS	66253049951	GOOD
	01	45	1	SGB 60 K VX	66253050138	BETTER
	01	45	1	38A 46 K VS	66253051108	GOOD
	01	45	1	3SG 46 J VX	66253055063	BEST
	01	45	1	3NQ 46 H VQN	66253262049	BEST
	01	45	2	2NQ 46 G VS3	66253348366	BEST
	01	45	1	SGB 46 J VX	69936623781	BETTER
	01	35	1	3SG 46 F VXP	69936623900	BEST
	01	45	1	38A 46 H VS	69936675912	GOOD
	01	35	1	38A 46 I VS	69936675913	GOOD
400x25x127	01	50	1	SGB 60 K VX	69936644046	BETTER
400x40x127	01	45	1	3SG 60 L VX	66243465059	BEST
	01	45	1	SGB 60 K VX	66253127873	BETTER
400x50x127	01	45	1	37C 60 K VK	69210431098	GOOD
	01	45	1	38A 60 L VS3	69210431108	BETTER
	01	45	1	38A 60 M VS3	69210431110	BETTER
400x50x203	01	50	1	38A 60 L VS3	69210431757	BETTER
406x25x127	01	45	1	SGA 80 I VXP	61463694555	BETTER
	01	45	1	3SG 60 L VX	66253055083	BEST
	01	50	1	38A 60 L VS	69936694018	GOOD
406x32x127	01	45	1	GF 60 L VX	66243469011	GOOD
	01	35	1	38A 60 L VS	66253049841	GOOD
406x40x127	01	50	1	39C 80 K VS	66243466414	GOOD
	01	45	1	SGB 60 K VX	66253049843	BETTER
	01	45	1	3SG 60 L VX	66253055086	BEST
	01	45	1	38A 60 J VS3	66253348356	BETTER

BONDED  
ABRASIVES

SUPER  
ABRASIVES

DIAMOND  
TOOLS

CLEANING,  
POLISHING  
& MASKING

PERSONAL  
PROTECTION  
EQUIPMENT

TECHNICAL  
INFORMATION

Dimensions Key: DIM: Dimensions, D: Diameter, T: Thickness, H: Hole

MOS: Maximum Operating Speed,  
PK QTY: Packaging Quantity

## STRAIGHT WHEELS

DIM DxTxH (mm)	SHAPE	MOS (m/s)	PK QTY	SPECIFICATION	ART. NO.	BEST/ BETTER/ GOOD
<b>SHAPE 01</b>						
406x50x127	01	50	1	SGA 80 I VXP	61463694556	BETTER
	01	35	1	SGA 46 K VS	61463699644	BETTER
	01	35	1	SGB 46 H VX	66243448363	BETTER
	01	45	1	5SG 46 G VXP	66243468188	BEST
	01	50	1	SGB 46 G VXP	66243468401	BETTER
	01	45	1	IPA 60 H VTX	66253049884	BETTER
	01	45	1	3SG 54 F VXP	66253054506	BEST
	01	45	1	38A 46 I VXP	66253054508	GOOD
	01	45	1	SGB 60 K VX	66253055072	BETTER
	01	50	1	3SG 46 H VX	66253055912	BEST
	01	35	1	38A 46 H VS	69936694574	GOOD
457x50x203,2	01	35	1	SGA 60 K VX	61463694560	BETTER
508x50x203,2	01	35	1	SGA 80 I VXP	61463699663	BETTER
	01	50	1	3SG 60 K VX	66253055088	BEST

## CYLINDERS

DIM DxTxH (mm)	SHAPE	MOS (m/s)	PK QTY	SPECIFICATION	ART. NO.	BEST/ BETTER/ GOOD
<b>SHAPE 02</b>						
200x100x160	02	45	1	38A 46 G VS3	66253348386	BETTER
	02	45	2	SGB 46 H VX	69936686693	BETTER
254x100x204	02	45	1	38A 46 G VS3	66253348387	BETTER

ART. NO. With **VITRIUM**  Revolutionary bond technology



## WHEELS RECESSED ONE SIDE

DIM DxTxH (mm)	P (mm)	F (mm)	SHAPE	MOS (m/s)	PK QTY	SPECIFICATION	ART. NO.	BEST/ BETTER/ GOOD
<b>SHAPE 05</b>								
200x25x50	110	10	05	35	2	32A 60 I VS	69936639342	GOOD
	110	10	05	35	2	32A 46 I VS	69936639420	GOOD
	110	10	05	35	2	3SG 60 I VS	69936639454	BEST
			05	45	2	38A 46 I VS	69936640254	GOOD
225x25x51			05	45	2	SGB 54 F VXP	69936640023	BETTER
250x32x76			05	45	1	32A 46 I VS	69936639419	GOOD
300x40x127			05	45	1	SGA 60 K VS	61463699585	BETTER
	190	12	05	50	1	38A 60 L VS	69936621532	GOOD
	190	13	05	35	1	3SG 60 K VS	69936621533	BEST
	190	13	05	35	1	38A 46 K VS	69936639643	GOOD
			05	45	1	32A 46 I VS	69936639807	GOOD
	190	13	05	35	1	3SG 54 F VXP	69936676709	BEST
			05	35	1	GF 46 F VXP	69936679817	GOOD
300x50x127	190	12	05	35	1	38A 46 F VXP	69936676708	GOOD
	190	12	05	35	1	SGB 60 L VX	69936678989	BETTER
355x40x127	215	13	05	35	1	38A 46 I VS	69936639355	GOOD
			05	45	1	3SG 60 K VS	69936640371	BEST
	215	13	05	35	1	SGB 46 F VXP	69936679012	BETTER
			05	35	1	GF 46 I VX	69936679798	GOOD
355x50x127	215	13	05	35	1	32A 46 J VS	69936639592	GOOD
	215	13	05	35	1	38A 46 J VS	69936639621	GOOD
	215	13	05	35	1	32A 46 K VS	69936639630	GOOD
	215	13	05	35	1	32A 46 I VS	69936639756	GOOD
	215	13	05	35	1	3SG 46 I VS	69936640195	BEST
	215	13	05	35	1	SGB 46 F VXP	69936640504	BETTER
	215	13	05	35	1	SGB 54 E VXP	69936640505	BETTER
			05	45	1	38A 46 I VS	69936640875	GOOD
355x50x127	215	13	05	35	1	32A 46 E VXP	69936676715	GOOD
	215	13	05	35	1	3SG 54 E VXP	69936676717	BEST
	205	9,5	05	35	1	3SG 46 F VXP	69936676719	BEST
	215	13	05	35	1	GF 46 J VX	69936679799	GOOD
	215	13	05	35	1	GF 46 I VX	69936679800	GOOD
			05	35	1	GF 54 E VXP	69936679819	GOOD

BONDED  
ABRASIVES

SUPER  
ABRASIVES

DIAMOND  
TOOLS

CLEANING,  
POLISHING  
& MASKING

PERSONAL  
PROTECTION  
EQUIPMENT

TECHNICAL  
INFORMATION

Dimensions Key: DIM: Dimensions, D: Diameter, T: Thickness, H: Hole

MOS: Maximum Operating Speed,  
PK QTY: Packaging Quantity

## WHEELS RECESSED ONE SIDE

DIM DxTxH (mm)	P (mm)	F (mm)	SHAPE	MOS (m/s)	PK QTY	SPECIFICATION	ART. NO.	BEST/ BETTER/ GOOD
<b>SHAPE 05</b>								
406x40x127			05	35	1	38A 60 M VS	66243448163	GOOD
			05	45	1	32A 60 K VS	66243448202	GOOD
			05	50	1	39C 60 J VS	66243468572	GOOD
406x50x127	215	13	05	35	1	32A 60 F VBEP	66243448133	GOOD
	215	13	05	35	1	32A 46 I VS	66243448172	GOOD
	215	13	05	35	1	38A 46 I VS	66243448178	GOOD
			05	35	1	3SG 46 I VS	66243448179	BEST
	215	13	05	35	1	32A 46 J VS	66243448205	GOOD
			05	45	1	32A 36 J VS	66243448251	GOOD
	215	13	05	35	1	3SG 54 E VXP	66243448671	BEST
	215	13	05	35	1	3SG 46 F VXP	66243448690	BEST
	215	13	05	35	1	38A 46 F VXP	66243448705	GOOD
	215	13	05	35	1	32A 46 F VXP	66243448726	GOOD
			05	45	1	SGB 46 F VXP	66243448824	BETTER
			05	45	1	3SG 54 D VXP	66243467861	BEST
	215	13	05	35	1	GF 46 I VX	66243469004	GOOD
	215	13	05	35	1	GF 46 F VXP	66243469021	GOOD
			05	45	1	GF 54 E VXP	66243469022	GOOD
508x63x203,2			05	35	1	2NQ 54 D VS3P	66253357022	BEST
			05	45	1	GF 60 K VX	66243468997	GOOD

BONDED  
ABRASIVES

SUPER  
ABRASIVES

DIAMOND  
TOOLS

CLEANING,  
POLISHING  
& MASKING

PERSONAL  
PROTECTION  
EQUIPMENT

TECHNICAL  
INFORMATION

ART. NO. With **VITRIUM**  Revolutionary bond technology

**WHEELS RECESSED BOTH SIDES**

DIM DxTxH (mm)	W (mm)	E (mm)	J (mm)	U (mm)	SHAPE	MOS (m/s)	PK QTY	SPECIFICATION	ART. NO.	BEST/ BETTER/ GOOD
 <b>SHAPE 07</b>										
300x40x75					07	45	1	32A 46 J VS	69936640287	GOOD
300x40x76					07	35	1	SGB 46 F VXP	69936679010	BETTER
					07	50	1	SGA 46 I VX	69936679011	BETTER
300x50x127					07	35	1	38A 46 I VS	69936639343	GOOD
					07	35	1	32A 46 K VS	69936639504	GOOD
					07	35	1	3SG 46 I VS	69936639644	BEST
					07	35	1	32A 46 J VS	69936640846	GOOD
					07	35	1	SGB 46 F VXP	69936676523	BETTER
					07	35	1	32A 60 E VXP	69936676711	GOOD
300x50x127					07	35	1	3SG 54 E VXP	69936676712	BEST
					07	35	1	GF 46 I VX	69936680954	GOOD
					07	45	1	GF 46 F VXP	69936680955	GOOD
300x50x76,2					07	35	1	IPA 60 H VTX	66253051621	BETTER
					07	35	1	3SG 46 H VS	69936672033	BEST
					07	35	1	38A 46 H VS	69936675893	GOOD
					07	35	1	38A 46 I VS	69936675894	GOOD
					07	35	1	5SG 46 G VXP	69936676591	BEST
					07	45	1	3SG 46 H VS	69936677015	BEST
350x50x127					07	45	1	SGB 46 G VXP	66243570780	BETTER
					07	35	1	38A 60 L VS	69936675899	GOOD
					07	35	1	3SG 46 G VXP	69936677215	BEST
355x63x127					07	45	1	SGB 46 F VXP	69936676716	BETTER
406x63x127					07	50	1	GF 46 F VXP	66243449251	GOOD
406x76x127					07	35	1	38A 46 F VBEP	66243448206	GOOD
					07	35	1	32A 46 I VS	66243448354	GOOD
					07	35	1	3SG 54 E VXP	66243448665	BEST
					07	35	1	SGB 46 F VXP	66243448691	BETTER
					07	35	1	GF 46 I VX	66243469001	GOOD
					07	35	1	GF 46 F VXP	66243469016	GOOD
406x100x152,4					07	35	1	GF 46 I VX	66243449285	GOOD
					07	35	1	GF 46 F VXP	66243449286	GOOD
406x100x152,4					07	50	1	3SG 54 E VXP	66243449287	BEST
					07	35	1	SGB 46 F VXP	66243468578	BETTER
457x80x203,2					07	45	1	GF 46 F VXP	66243469018	GOOD

BONDED  
ABRASIVES

SUPER  
ABRASIVES

DIAMOND  
TOOLS

CLEANING,  
POLISHING  
& MASKING

PERSONAL  
PROTECTION  
EQUIPMENT

TECHNICAL  
INFORMATION

**Dimensions Key:** DIM: Dimensions, P: Recess Diameter, F: Recess Depth, W: Rim Width; E: Back Thickness, J: External Flat Diameter, K: Internal Flat Diameter, U: Rim Depth

**MOS:** Maximum Operating Speed, **PK QTY:** Packaging Quantity

## SEGMENTS

DIM LxBxC (mm)	SEGMENT		SHAPE	MOS (m/s)	PK QTY	SPECIFICATION	ART. NO.	BEST/ BETTER/ GOOD
	A(mm)	R(mm)						
 <b>SHAPE 31</b>								
16x50x90	45	91	31		4	2NQ 36 H VS3	66253348492	BEST
	45	91	31		4	38A 46 G VS3	66253348493	BETTER
	45	91	31		4	2NQ 46 G VS3	66253348781	BEST
	45	91	31		4	38A 36 H VS3	66253348785	BETTER
	45	91	31		4	3NQ 46 H VQN	69083141440	BEST
16x53,5x110	47	89	31		4	38A 36 I VS	69936688485	GOOD
	47	89	31	45	1	38A 46 H VS	69936688614	GOOD
20x65x60			31		4	32A 36 I VS	69936682266	GOOD
21x59,5x121	48		31		4	38A 36 H VS3	66253348638	BETTER
	48		31		2	38A 30 H VS	69936624796	GOOD
			31		4	32A 46 H VS	69936682244	GOOD
22x60x110	54		31		4	38A 36 H VS3	66253348665	BETTER
	54		31	45	1	2NQ 36 G VS3	66253348778	BEST
25x40x300			31		1	37C 16 T V	69210431485	GOOD
			31		4	37C 36 T V	69210432327	GOOD
25x50x110	43,5		31		4	3SG 60 G VX	66253050282	BEST
	43,5		31		4	38A 46 G VS3	66253348779	BETTER
	43,5		31		4	38A 60 G VS3	66253348786	BETTER
	43,5		31		2	19A 54 I VS	69936686249	GOOD
25x65x100			31		4	32A 30 I VS	69936682494	GOOD
	56,9	205	31		4	37C 30 H V	69936688426	GOOD
			31		4	37C 36 G V	69936688530	GOOD
25x70x110	64		31		4	38A 36 I VS	69936682640	GOOD
25x70x150	64		31		4	38A 36 H VS3	66253348783	BETTER
			31		4	32A 36 H VS	69936682251	GOOD
			31		1	3SG 36 E VXP	69936688295	BEST
25x80x150			31		4	38A 36 H VBE	69210431972	GOOD
			31		4	38A 30 I VS	69936686253	GOOD
			31		4	3SG 36 E VXP	69936688321	BEST
25x80x160	80	210	31		4	3SG 30 E VXP	69936688296	BEST
25x84x120			31		2	38A 36 I VS	69936682222	GOOD

BONDED  
ABRASIVES

SUPER  
ABRASIVES

DIAMOND  
TOOLS

CLEANING,  
POLISHING  
& MASKING

PERSONAL  
PROTECTION  
EQUIPMENT

TECHNICAL  
INFORMATION

ART. NO. With **VITRIUM**  Revolutionary bond technology

DIM LxBxC (mm)	SEGMENT		SHAPE	MOS (m/s)	PK QTY	SPECIFICATION	ART. NO.	BEST/ BETTER/ GOOD
	A(mm)	R(mm)						
 <b>SHAPE 31</b>								
35x90x150			31		10	38A 24 H VBE	69210431976	GOOD
			31		4	3SG 36 E VXP	69936689099	BEST
38x103x150	84,8	228,6	31		4	38A 36 G VS3	66253348825	BETTER
38x103x180			31		4	3SG 36 H VX	66253050287	BEST
	94		31		4	38A 30 H VS3	66253348780	BETTER
	94		31		4	3NQ 36 H VQN	69083141453	BEST
			31		4	38A 36 H VS	69936686271	GOOD
	94		31	45	1	3SG 30 E VXP	69936688298	BEST
40x250x250			31		2	38A 100 J VBE	61463669913	GOOD
			31		2	38A 220 I VBE	66243481697	GOOD
			31		2	38A 80 J VBE	66253285298	GOOD
			31		2	38A 120 J VBE	69210432522	GOOD
			31	35	1	38A 180 J VBE	69210433559	GOOD
50x200x250			31		2	38A 120 J VBE	310404831	GOOD
			31		2	38A 150 J VBE	69210438573	GOOD
			31		2	38A 80 J VBE	66253054925	GOOD
			31	45	1	38A 120 J VBE	69210432322	GOOD

BONDED  
ABRASIVES

SUPER  
ABRASIVES

DIAMOND  
TOOLS

CLEANING,  
POLISHING  
& MASKING

PERSONAL  
PROTECTION  
EQUIPMENT

TECHNICAL  
INFORMATION



# EXTERNAL CYLINDRICAL GRINDING (OD)

Norton's leading technology, provides you with the best precision, form holding vitrified wheels to maximize productivity, increase grinding efficiency and improve part quality in all your external cylindrical grinding operations.

For OD Grinding, please take note of the safety instructions, about the storage and use of grinding wheels, available on page 564.

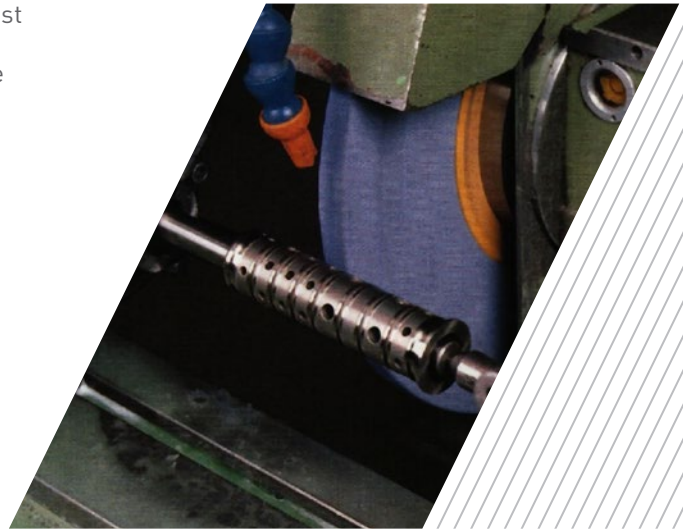

BONDED ABRASIVES

SUPER ABRASIVES

DIAMOND TOOLS

CLEANING, POLISHING & MASKING

PERSONAL PROTECTION EQUIPMENT

TECHNICAL INFORMATION

	STEELS									NON-FERROUS METALS			CERAMICS			POLYMERS	
	AEROSPACE ALLOYS: NIMONIC, INCONEL, HASTALLOY	CAST IRON	CHROME PLATE	HIGH SPEED STEEL	INOX	STEEL - SOFT (UP TO 49RC)	STEEL HARDENED (OVER 56RC)	STEEL HIGH CARBON / HIGH CHROME CONTENT	STELLITE	ALUMINIUM	TITANIUM	TUNGSTEN CARBIDE	CERAMIC (FIRE)	CERAMIC (GREEN)	METAL SPRAY	PLASTICS	RUBBER
NQ	X	X	X	X	X	X	X	X	X							X	
SG / GF	X	X		X		X	X										
19A / 57A						X											
25A / 86A / 32A						X	X										
37C		X							X						X	X	
38A	X	X	X	X		X	X	X	X				X				
39C					X					X	X	X	X	X	X		

## NORTON QUANTUM WITH VITRIUM<sup>3</sup> 5NQ

BEST +++++

INNOVATION

REVOLUTIONARY BOND TECHNOLOGY

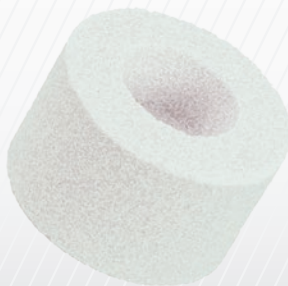

### FEATURES

- Engineered ceramic grain shape and chemistry with new revolutionary bond
- Perfect combination of sharpness and toughness

### BENEFITS

- Extreme versatility for all precision applications
- Reduced dressing frequency and cost
- High profile accuracy
- Cooler cut and high speed material removal

## NORTON QUANTUM 3NQ / 2NQ

BEST +++++



### FEATURES

- Engineered ceramic grain shape and chemistry with new bond technology
- A perfect blend between sharpness (free cutting) and toughness (life)

### BENEFITS

- Versatile in all low, medium and high force applications
- 30% to 100% higher metal removal rate
- >15% lower threshold power



## SG 3SG

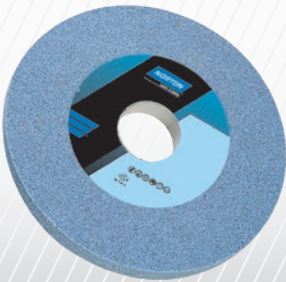

### FEATURES

- High concentration of SG ceramic aluminum oxide abrasive
- Unique, self sharpening, microcrystalline structure

### BENEFITS

- Very good cutting capability
- High removal rate & extended wheel life
- Suitable for very hard steels

BONDED ABRASIVES

SUPER ABRASIVES

## 38A WITH VITRIUM<sup>3</sup>

BETTER ++++

REVOLUTIONARY BOND TECHNOLOGY

VITRIUM<sup>3</sup>



### FEATURES

- High purity white aluminium oxide abrasives with enhanced bond adhesion
- High friability abrasive

### BENEFITS

- Even cooler & burn free cutting
- Extended wheel life
- Improved profile accuracy
- Ideal for heat sensitive applications with light to moderate feed rates



LINK TO WEBSITE AND ANIMATION

DIAMOND TOOLS

CLEANING, POLISHING & MASKING

PERSONAL PROTECTION EQUIPMENT

TECHNICAL INFORMATION

## SG SGA / SGB



### FEATURES

- Medium concentration of SG ceramic aluminum oxide
- Harder & sharper than conventional abrasive grains

### BENEFITS

- Good cutting capability
- Suitable for low to medium power machines
- Very versatile on a wide variety of steels

## 38A



### FEATURES

- High purity white aluminium oxide abrasive
- Friable

### BENEFITS

- Cool & burn free cutting
- Ideal for heat-sensitive applications with light to moderate feed rates

GOOD +++

## 19A



### FEATURES

- A blend of A & 38A abrasives
- Primarily used in saw grinding applications

### BENEFITS

- Very versatile. For use on a wide variety of steels
- Good yield, good removal rate
- Good balance between cut rate & form holding ability

## 39C

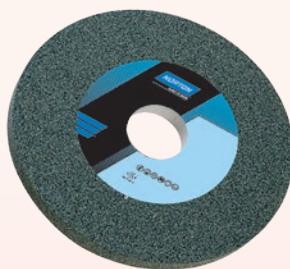

### FEATURES

- Highest purity green silicon carbide abrasive
- Harder & more friable than aluminium oxide abrasive

### BENEFITS

- Ideal for precision grinding & sharpening applications on metal carbide

BONDED ABRASIVES

SUPER ABRASIVES

DIAMOND TOOLS

CLEANING, POLISHING & MASKING

PERSONAL PROTECTION EQUIPMENT

TECHNICAL INFORMATION

37C



**FEATURES**

- High purity black silicon carbide abrasive
- Harder & more friable than aluminum oxide abrasive

**BENEFITS**

- Suitable for roughing operations in coarse grit & resinoid wheels
- Ideal for grinding & sharpening applications on metal carbide & non-ferrous metals

**STRAIGHT WHEELS**

DIM DxTxH (mm)	SHAPE	MOS (m/s)	PK QTY	SPECIFICATION	ART. NO.	BEST/ BETTER/ GOOD
<div style="display: flex; align-items: center;"> <div style="width: 15px; height: 10px; background-color: black; margin-right: 5px;"></div> <div style="width: 15px; height: 10px; background-color: black; margin-right: 5px;"></div> <div>SHAPE 01</div> </div>						
300x25x127	01	50	1	SGA 60 K VX	61463693967	BETTER
	01	50	1	SGA 80 L VX	61463693973	BETTER
	01	45	1	SGA 46 K VS	61463699584	BETTER
	01	45	1	38A 60 K VS	66253050105	GOOD
	01	45	1	SGB 60 K VX	66253050132	BETTER
	01	45	1	3SG 46 K VX	66253055050	BEST
	01	45	1	3NQ 60 K VQN	66253262040	BEST
	01	63	2	2NQ 60 J VS3	66253348372	BEST
	01	63	2	38A 60 K VS3	66253354042	BETTER
	01	45	1	38A 46 K VS3	66253354043	BETTER
	01	35	1	38A 80 L VS	69936623648	GOOD
	01	45	1	38A 46 J VS	69936623662	GOOD
	01	50	1	39C 60 K VS	69936623687	GOOD
300x25x127	01	45	1	19A 60 M VS	69936623719	GOOD
	01	35	1	39C 80 J VS	69936640343	GOOD
	01	45	1	39C 120 K VS	69936675646	GOOD

**Dimensions Key:** DIM: Dimensions, D: Diameter, T: Thickness, H: Hole

MOS: Maximum Operating Speed,  
PK QTY: Packaging Quantity

ART. NO. With **VITRIUM** Revolutionary bond technology

BONDED ABRASIVES

SUPER ABRASIVES

DIAMOND TOOLS

CLEANING, POLISHING & MASKING

PERSONAL PROTECTION EQUIPMENT

TECHNICAL INFORMATION

## STRAIGHT WHEELS

DIM DxTxH (mm)	SHAPE	MOS (m/s)	PK QTY	SPECIFICATION	ART. NO.	BEST/ BETTER/ GOOD
<b>SHAPE 01</b>						
300x32x127	01	45	1	3SG 60 K VX	66253055872	BEST
	01	45	1	38A 46 H VS	69936675883	GOOD
	01	45	1	38A 60 L VS	69936675884	GOOD
	01	45	1	SGB 60 K VX	69936676386	BETTER
	01	35	1	GF 46 I VX	69936679795	GOOD
300x32x76,2	01	45	1	38A 46 H VS	69936675880	GOOD
300x40x76	01	35	1	38A 60 K VS	66253049953	GOOD
300x40x127	01	45	1	SGB 60 K VX	66253050179	BETTER
	01	45	1	3SG 60 K VX	66253055053	BEST
	01	45	1	3SG 46 H VX	66253055893	BEST
	01	35	1	37C 60 K VK	69210431073	GOOD
	01	45	1	39C 80 K VS	69936675649	GOOD
	01	35	1	39C 60 K VS	69936675684	GOOD
	01	35	1	38A 46 H VS	69936675888	GOOD
	01	35	1	38A 60 L VS	69936675891	GOOD
300x50x127	01	35	1	GF 60 K VX	69936680686	GOOD
350x40x51	01	35	3	38A 46 J VS	69936623649	GOOD
	01	32	3	37C 60 K VK	69210431101	GOOD
350x40x127	01	32	3	38A 60 L VS3	69210432052	BETTER
	01	35	3	37C 60 K VK	69210431889	GOOD
	01	35	3	37C 60 J VK	69210432038	GOOD
350x50x127	01	35	1	39C 60 K VK	69210432040	GOOD
	01	35	2	38A 80 L VS3	69210431072	BETTER
350x63x127	01	35	1	37C 60 K VK	69210431686	GOOD
	01	35	1	38A 46 L VS3	69210431074	BETTER
355x25x127	01	50	1	38A 60 L VS3	69210431076	BETTER
	01	45	1	SGA 46 J VS	61463699586	BETTER
	01	45	1	SGB 60 L VX	66253050135	BETTER
	01	50	1	3SG 60 L VX	66253055895	BEST
	01	45	1	3SG 60 K VS	69936623716	BEST
355x32x127	01	45	1	38A 60 L VS	69936675901	GOOD
	01	35	1	2NQ 60 J VS3	66253348373	BEST
	01	35	1	3SG 80 K VS	69936638294	BEST
355x32x127	01	35	1	38A 60 M VS	69936639074	GOOD
355x32x127	01	45	1	38A 60 L VS	69936675903	GOOD

BONDED  
ABRASIVES

SUPER  
ABRASIVES

DIAMOND  
TOOLS

CLEANING,  
POLISHING  
& MASKING

PERSONAL  
PROTECTION  
EQUIPMENT

TECHNICAL  
INFORMATION

ART. NO. With **VITRIUM** Revolutionary bond technology



DIM DxTxH (mm)	SHAPE	MOS (m/s)	PK QTY	SPECIFICATION	ART. NO.	BEST/ BETTER/ GOOD
<b>SHAPE 01</b>						
355x40x127	01	45	1	SGB 46 J VX	66253050117	BETTER
	01	45	1	3SG 60 L VX	66253055057	BEST
	01	50	1	2NQ 46 G VS3	66253348367	BEST
	01	45	1	3SG 60 K VS	69936623611	BEST
	01	35	1	38A 46 J VS	69936623753	GOOD
	01	35	1	39C 60 K VS	69936675685	GOOD
	01	45	1	38A 46 H VS	69936675906	GOOD
	01	35	1	38A 60 L VS	69936675908	GOOD
355x50x127	01	45	1	38A 60 K VS	66253049951	GOOD
	01	45	1	SGB 60 K VX	66253050138	BETTER
	01	45	1	38A 46 K VS	66253051108	GOOD
	01	45	1	3SG 46 J VX	66253055063	BEST
	01	45	1	3NQ 46 H VQN	66253262049	BEST
	01	45	2	2NQ 46 G VS3	66253348366	BEST
	01	45	1	SGB 46 J VX	69936623781	BETTER
	01	45	1	38A 46 H VS	69936675912	GOOD
400x25x127	01	35	1	38A 46 I VS	69936675913	GOOD
400x40x127	01	50	1	SGB 60 K VX	69936644046	BETTER
	01	45	1	3SG 60 L VX	66243465059	BEST
400x50x127	01	45	1	SGB 60 K VX	66253127873	BETTER
	01	45	1	37C 60 K VK	69210431098	GOOD
	01	45	1	38A 60 L VS3	69210431108	BETTER
400x50x203	01	45	1	38A 60 M VS3	69210431110	BETTER
	01	50	1	38A 60 L VS3	69210431757	BETTER
	01	45	1	3SG 60 L VX	66253055083	BEST
406x25x127	01	50	1	38A 60 L VS	69936694018	GOOD
406x32x127	01	45	1	GF 60 L VX	66243469011	GOOD
	01	35	1	38A 60 L VS	66253049841	GOOD
406x40x127	01	50	1	39C 80 K VS	66243466414	GOOD
457x50x127	01	50	1	38A 60 L VS	66243466558	GOOD
457x50x203,2	01	35	1	SGA 60 K VX	61463694560	BETTER
500x50x203	01	45	1	38A 60 L VS3	69210431122	BETTER
500x63x203	01	50	1	38A 60 L VS3	69210432055	BETTER
508x50x203,2	01	35	1	SGA 80 I VXP	61463699663	BETTER
	01	45	1	38A 60 L VS	66243466565	GOOD
600x90x305	01	45	1	37C 70 K VK	66253146863	GOOD
610x170x304,8	01	50	1	39C 120 K VS	66253366323	GOOD

Dimensions Key: DIM: Dimensions, D: Diameter, T: Thickness, H: Hole

MOS: Maximum Operating Speed,  
PK QTY: Packaging Quantity

BONDED  
ABRASIVES

SUPER  
ABRASIVES

DIAMOND  
TOOLS

CLEANING,  
POLISHING  
& MASKING

PERSONAL  
PROTECTION  
EQUIPMENT

TECHNICAL  
INFORMATION

## WHEELS RECESSED ONE SIDE

DIM DxTxH (mm)	P (mm)	F (mm)	SHAPE	MOS (m/s)	PK QTY	SPECIFICATION	ART. NO.	BEST/ BETTER/ GOOD
<b>SHAPE 05</b>								
300x40x127			05	45	1	SGA 60 K VS	61463699585	BETTER
	190	12	05	50	1	38A 60 L VS	69936621532	GOOD
	190	13	05	35	1	3SG 60 K VS	69936621533	BEST
	190	13	05	35	1	38A 46 K VS	69936639643	GOOD
			05	45	1	32A 46 I VS	69936639807	GOOD
300x50x127	190	12	05	35	1	SGB 60 L VX	69936678989	BETTER
355x40x127	215	13	05	35	1	38A 46 I VS	69936639355	GOOD
			05	45	1	3SG 60 K VS	69936640371	BEST
			05	35	1	GF 46 I VX	69936679798	GOOD
355x50x127	215	13	05	35	1	32A 46 J VS	69936639592	GOOD
	215	13	05	35	1	38A 46 J VS	69936639621	GOOD
	215	13	05	35	1	32A 46 K VS	69936639630	GOOD
	215	13	05	35	1	32A 46 I VS	69936639756	GOOD
	215	13	05	35	1	3SG 46 I VS	69936640195	BEST
			05	45	1	38A 46 I VS	69936640875	GOOD
	215	13	05	35	1	GF 46 J VX	69936679799	GOOD
	215	13	05	35	1	GF 46 I VX	69936679800	GOOD
406x40x127			05	35	1	38A 60 M VS	66243448163	GOOD
			05	45	1	32A 60 K VS	66243448202	GOOD
			05	50	1	39C 60 J VS	66243468572	GOOD
406x50x127			05	50	1	GF 60 L VX	66243468990	GOOD
508x63x203,2			05	45	1	GF 60 K VX	66243468997	GOOD

## WHEELS RECESSED BOTH SIDES

DIM DxTxH (mm)	W (mm)	E (mm)	J (mm)	U (mm)	SHAPE	MOS (m/s)	PK QTY	SPECIFICATION	ART. NO.	BEST/ BETTER/ GOOD
<b>SHAPE 07</b>										
300x40x76					07	50	1	SGA 46 I VX	69936679011	BETTER
300x50x127					07	35		38A 46 I VS	69936639343	GOOD
					07	35		32A 46 K VS	69936639504	GOOD
					07	35		3SG 46 I VS	69936639644	BEST
					07	35		32A 46 J VS	69936640846	GOOD
					07	35		GF 46 I VX	69936680954	GOOD
					07	35	1	3SG 46 H VS	69936672033	BEST
300x50x76,2					07	35	1	38A 46 H VS	69936675893	GOOD
					07	35	1	38A 46 I VS	69936675894	GOOD
					07	45	1	3SG 46 H VS	69936677015	BEST
355x50x127					07	35	1	38A 60 L VS	69936675899	GOOD

ART. NO. With **VITRIUM** Revolutionary bond technology

## WHEELS RELIEVED ONE SIDE

DIM DxTxH (mm)	W (mm)	E (mm)	J (mm)	U (mm)	SHAPE	MOS (m/s)	PK QTY	SPECIFICATION	ART. NO.	BEST/ BETTER/ GOOD
 <b>SHAPE 20</b>										
300x32x127					20	45	1	38A 60 M VS	69936682634	GOOD
300x40x127					20	35	1	38A 60 M VS	69936682310	GOOD
					20	35	1	GF 60 M VX	69936689193	GOOD
355x32x127					20	50	1	SGB 60 L VX	69936688869	BETTER
355x40x127					20	35	1	38A 60 M VS	69936682253	GOOD
					20	50	1	38A 60 O VS	69936682695	GOOD
					20	50	1	SGB 60 L VX	69936688870	BETTER
355x50x127					20	50	1	GF 60 L VX	69936689195	GOOD
					20	50	1	38A 60 M VS	69936682268	GOOD
406x40x127					20	35	1	38A 60 N VS	66243448167	GOOD
					20	45	1	GF 60 K VX	66243469015	GOOD
406x50x127					20	32	1	38A 60 M VS	66243448116	GOOD
					20	35	1	38A 60 K VS	66243448201	GOOD
					20	35	1	3SG 60 K VS	66243448204	BEST
					20	50	1	GF 60 L VX	66243468989	GOOD
					20	35	1	GF 60 K VX	66243468991	GOOD
406x63x127					20	35	1	2NQ 60 J VS3	66253356830	BEST
					20	35	1	GF 60 L VX	66243468993	GOOD
457x50x127					20	45	1	38A 60 M VS	66243448676	GOOD
					20	50	1	GF 60 L VX	66243468995	GOOD
457x63x127					20	35	1	GF 60 L VX	66243468996	GOOD
508x60x203,2					20	50	1	SGB 60 K VX	66243468575	BETTER
508x80x203,2					20	45	1	GF 60 K VX	66243468998	GOOD

**Dimensions Key:** DIM: Dimensions, P: Recess Diameter, F: Recess Depth, W: Rim Width; E: Back Thickness, J: External Flat Diameter, K: Internal Flat Diameter, U: Rim Depth

MOS: Maximum Operating Speed, PK QTY: Packaging Quantity

BONDED  
ABRASIVES

SUPER  
ABRASIVES

DIAMOND  
TOOLS

CLEANING,  
POLISHING  
& MASKING

PERSONAL  
PROTECTION  
EQUIPMENT

TECHNICAL  
INFORMATION

# INTERNAL CYLINDRICAL GRINDING (ID)

Fruit of historical and technical expertise, Norton's bond and abrasive grain formulations are optimized to best suit the technical request of your ID grinding operations: Perfect geometry (roundness, conicity of the part) and good surface finish.

For ID Grinding, please take note of the safety instructions, about the storage and use of grinding wheels, available on page 564.

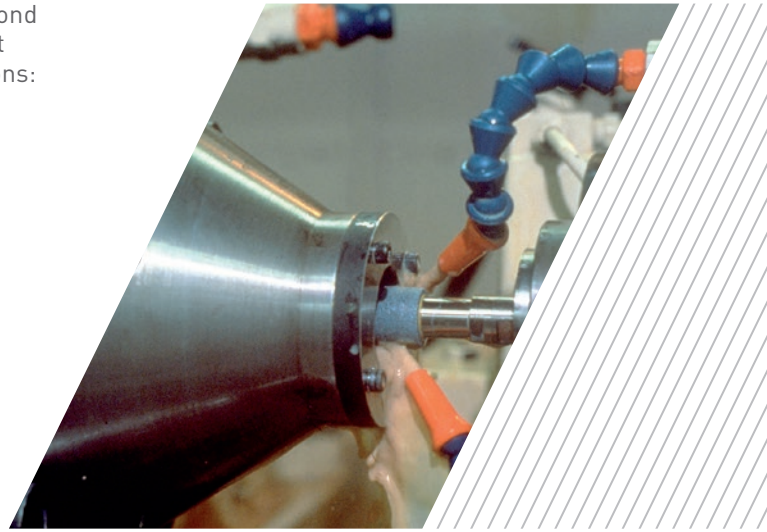

BONDED  
ABRASIVES

SUPER  
ABRASIVES

DIAMOND  
TOOLS

CLEANING,  
POLISHING  
& MASKING

PERSONAL  
PROTECTION  
EQUIPMENT

TECHNICAL  
INFORMATION

	STEELS									NON-FERROUS METALS			CERAMICS			POLYMERS	
	AEROSPACE ALLOYS: NIMONIC, INCONEL, HASTALLOY	CAST IRON	CHROME PLATE	HIGH SPEED STEEL	INOX	STEEL - SOFT (UP TO 45RC)	STEEL HARDENED (OVER 54RC)	STEEL-HIGH CARBON / HIGH CHROME CONTENT	STELLITE	ALUMINIUM	TITANIUM	TUNGSTEN CARBIDE	CERAMIC (FIRED)	CERAMIC (GREEN)	METAL SPRAY	PLASTICS	RUBBER
NQ	x	x	x	x	x	x	x	x	x							x	
SG / GF	x	x		x		x	x										
25A / 86A / 32A						x	x										
37C		x							x						x	x	
38A	x	x	x	x		x	x	x	x				x				
39C					x					x	x	x	x	x	x		

## NORTON QUANTUM WITH VITRIUM<sup>3</sup> 5NQ

BEST +++++

INNOVATION

### REVOLUTIONARY BOND TECHNOLOGY

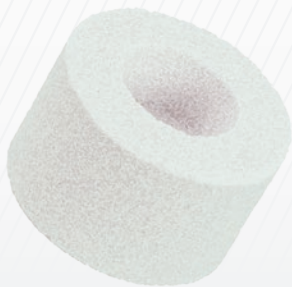

#### FEATURES

- Engineered ceramic grain shape and chemistry with new revolutionary bond
- Perfect combination of sharpness and toughness

#### BENEFITS

- Extreme versatility for all precision applications
- Reduced dressing frequency and cost
- High profile accuracy
- Cooler cut and high speed material removal

## NORTON QUANTUM 5NQ / 3NQ

BEST +++++



### FEATURES

- Engineered ceramic grain shape and chemistry with new bond technology
- A perfect blend between sharpness (free cutting) and toughness (life)

### BENEFITS

- Versatile in all low, medium and high force applications
- 30% to 100% higher metal removal rate
- >15% lower threshold power



## SG 5SG

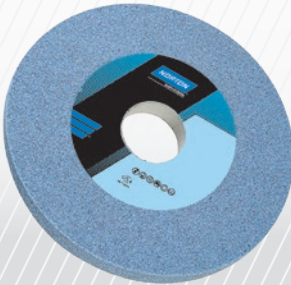

### FEATURES

- Very high concentration of SG ceramic aluminium oxide abrasive

### BENEFITS

- Ultimate cutting capability
- High removal rate & extended wheel life
- Perfect for technical applications where grinding parameters can be adjusted to optimise performance

## SG 3SG

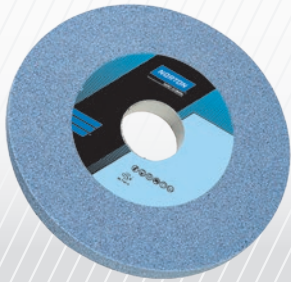

### FEATURES

- High concentration of SG ceramic aluminum oxide abrasive
- Unique, self sharpening, microcrystalline structure

### BENEFITS

- Very good cutting capability
- High removal rate & extended wheel life
- Suitable for very hard steels

## 38A WITH VITRIUM<sup>3</sup>

BETTER ++++

REVOLUTIONARY BOND TECHNOLOGY

VITRIUM<sup>3</sup>



### FEATURES

- High purity white aluminium oxide abrasives with enhanced bond adhesion
- High friability abrasive

### BENEFITS

- Even cooler & burn free cutting
- Extended wheel life
- Improved profile accuracy
- Ideal for heat sensitive applications with light to moderate feed rates

BONDED  
ABRASIVES

SUPER  
ABRASIVES

DIAMOND  
TOOLS

CLEANING,  
POLISHING  
& MASKING

PERSONAL  
PROTECTION  
EQUIPMENT

TECHNICAL  
INFORMATION



## SG SGB

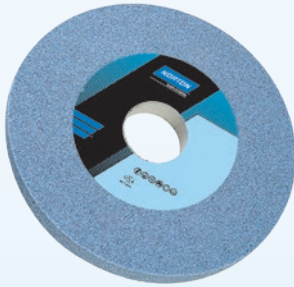

### FEATURES

- Medium concentration of SG ceramic aluminum oxide
- Harder & sharper than conventional abrasive grains

### BENEFITS

- Good cutting capability
- Suitable for low to medium power machines
- Very versatile on a wide variety of steels

## 38A



### FEATURES

- High purity white aluminium oxide abrasive
- Friable

### BENEFITS

- Cool & burn free cutting
- Ideal for heat-sensitive applications with light to moderate feed rates

GOOD +++

## 39C

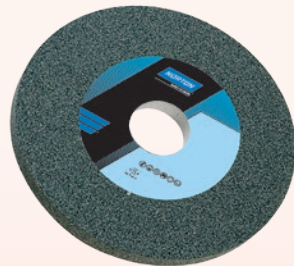

### FEATURES

- Highest purity green silicon carbide abrasive
- Harder & more friable than aluminium oxide abrasive

### BENEFITS

- Ideal for precision grinding & sharpening applications on metal carbide

## 37C



### FEATURES

- High purity black silicon carbide abrasive
- Harder & more friable than aluminum oxide abrasive

### BENEFITS

- Suitable for roughing operations in coarse grit & resinoid wheels
- Ideal for grinding & sharpening applications on metal carbide & non-ferrous metals

ART. NO. With **VITRIUM**  Revolutionary bond technology

352 BONDED ABRASIVES

BONDED ABRASIVES

SUPER ABRASIVES

DIAMOND TOOLS

CLEANING, POLISHING & MASKING

PERSONAL PROTECTION EQUIPMENT

TECHNICAL INFORMATION

## STRAIGHT WHEELS

DIM DxTxH (mm)	SHAPE	MOS (m/s)	PK QTY	SPECIFICATION	ART. NO.	BEST/ BETTER/ GOOD
<b>SHAPE 01</b>						
10x10x3,18	01	35	10	SGB 60 J VS3	66253355175	BEST
13x13x4	01	63	10	5NQ 80 K VS3	66253348357	BEST
13x13x4,76	01	63	10	SGB 60 J VS3	66253355176	BEST
16x16x6	01	35	10	5NQ 80 J VQN	66253244881	BEST
	01	35	10	3NQ 60 K VS3	66253348360	BEST
20x20x6	01	35	10	3NQ 60 L VQN	66253261903	BEST
	01	35	10	38A 60 K VS3	66253348355	BETTER
20x20x6,35	01	63	10	SGB 60 J VS3	66253355179	BEST
63x10x20	01	45	10	38A 60 N VS	66253050376	GOOD
70x7,1x17	01	45	10	3NQ 60 L VS3	66253348329	BEST
76x25x12,7	01	32	10	39C 80 IV	66253052726	GOOD
	01	45	10	37C 80 J VS	69936639604	GOOD

## WHEELS RECESSED ONE SIDE

DIM DxTxH (mm)	P (mm)	F (mm)	SHAPE	MOS (m/s)	PK QTY	SPECIFICATION	ART. NO.	BEST/ BETTER/ GOOD
<b>SHAPE 05</b>								
13x13x4,76	6	6	05	45	10	SGB 60 J VS3	66253355177	BEST
16x16x6	10	8	05	35	10	5NQ 60 K VS3	66253348333	BEST
20x20x6	13	10	05	45	10	5NQ 80 J VQN	66253244883	BEST
	13	10	05	45	10	5NQ 60 K VS3	66253348335	BEST
	13	10	05	35	10	SGB 60 K VX	69936681793	BETTER
20x20x6,35	10	10	05	63	10	5NQ 60 K VQN	66253244884	BEST
	10	10	05	35	10	SGB 60 J VS3	66253355181	BEST
			05		4	38A 60 L VS	69936621542	GOOD
25x25x8	13	10	05	35	10	5NQ 80 J VQN	66253244887	BEST
	13	12	05	35	10	5NQ 60 K VS3	66253348317	BEST
	13	10	05	45	10	SGB 60 K VX	69936681795	BETTER
25x25x6,35	13	12	05	45	10	5NQ 80 IVQN	66253244885	BEST
	13	12	05	63	10	38A 60 K VS3	66253348349	BETTER
	13	12	05		10	SGB 60 J VS3	66253355182	BEST
32x25x8	13	10	05	35	10	5NQ 60 J VQN	66253244888	BEST
32x32x8			05	35	10	5SG 60 K VS	69936639439	BEST
32x32x10			05	35	10	32A 60 K VS	69936639534	GOOD
32x32x10			05	45	10	5SG 60 K VS	69936639605	BEST

Dimensions Key: DIM: Dimensions, P: Recess Diameter, F: Recess Depth

MOS: Maximum Operating Speed,  
PK QTY: Packaging Quantity

## WHEELS RECESSED ONE SIDE

DIM DxTxH (mm)	P (mm)	F (mm)	SHAPE	MOS (m/s)	PK QTY	SPECIFICATION	ART. NO.	BEST/ BETTER/ GOOD
 <b>SHAPE 05</b>								
32x32x10	16	16	05	45	10	SGB 60 J VX	69936676291	BETTER
32x32x9,53	16	16	05	63	10	5NQ 80 I VQN	66253244898	BEST
	16	16	05		10	SGB 60 J VS3	66253355183	BEST
40x25x10	16	12	05	35	15	5NQ 80 K VQN	66253244890	BEST
			05	45	10	5SG 60 K VS	69936639834	BEST
40x25x9,53	20	12	05	63	10	5NQ 60 K VQN	66253244889	BEST
	20	12	05	45	10	SGB 60 J VS3	66253355184	BEST
40x32x10	20	16	05	35	10	5NQ 60 L VQN	66253244891	BEST
40x40x10	16	20	05	63	10	5NQ 60 J VS3	66253348334	BEST
40x40x12,7	20	20	05		20	SGB 60 J VS3	66253355185	BEST
50x25x10			05	32	10	5SG 60 K VS	69936640900	BEST
50x40x16	25	20	05	35	5	5NQ 60 J VS3	66253348348	BEST
			05	45	10	32A 60 K VS	69936640179	GOOD
50x40x12,7	25	20	05	63	10	5NQ 60 K VQN	66253244892	BEST
	25	20	05	63	10	SGB 60 J VS3	66253355186	BEST
63x40x12,7	32	20	05	63	10	5NQ 80 I VQN	66253244895	BEST
	32	20	05	45	10	SGB 60 J VS3	66253355187	BEST
	32	20	05	35	10	38A 60 L VS	69936621565	GOOD
64x32x20			05	35	10	5SG 54 K VS	69936639393	BEST
64x40x20			05	35	10	32A 46 M VS	69936640984	GOOD
76x32x20	42	16	05	35	10	5NQ 60 J VQN	66253244896	BEST
			05	35	5	32A 60 K VS	69936640253	GOOD
			05	45	10	5SG 54 K VS	69936640320	BEST
100x40x32			05	45	2	32A 60 K VS	69936678998	GOOD

**Dimensions Key:** DIM: Dimensions, P: Recess Diameter, F: Recess Depth

MOS: Maximum Operating Speed,  
PK QTY: Packaging Quantity

ART. NO. With **VITRIUM** Revolutionary bond technology

# BENCH AND PEDESTAL WHEELS

The Norton bench and pedestal wheels line consists of all wheel diameters and arbor sizes, abrasive types and grit sizes. Our offering answers all metal removal, deburring, shaping and sharpening needs: white aluminum oxide for high-speed tool steels, brown aluminum oxide for carbon steel, and silicon carbide for non-ferrous metals and carbide tooling.

For bench and pedestal grinding, please take note of the safety instructions, about the storage and use of grinding wheels, available on page 564.



	STEELS									NON-FERROUS METALS		
	AEROSPACE ALLOYS: NIMONIC, INCONEL, HASTALLOY	CAST IRON	CHROME PLATE	HIGH SPEED STEEL	INOX	STEEL - SOFT (UP TO 45RC)	STEEL HARDENED (OVER 54RC)	STEEL-HIGH CARBON / HIGH CHROME CONTENT	STELLITE	ALUMINIUM	TITANIUM	TUNGSTEN CARBIDE
38A	X	X	X	X		X	X	X	X			
39C					X					X	X	X
A						X	X					

## STARLINE BROWN ALUMINIUM OXIDE

**GOOD +++**



For steel removal, shaping and deburring.

### FEATURES

- High quality aluminium oxide in a premium vitrified bond
- Precision engineered grit sizes and hardness

### BENEFITS

- Maximised cut rate finish and wheel life



BONDED ABRASIVES

SUPER ABRASIVES

DIAMOND TOOLS

CLEANING, POLISHING & MASKING

PERSONAL PROTECTION EQUIPMENT

TECHNICAL INFORMATION

## STARLINE WHITE ALUMINIUM OXIDE

GOOD +++



For light material removal and sharpening of high speed tool steels.

### FEATURES

- White aluminium oxide in a premium vitrified bond
- Precision engineered grit sizes and hardness

### BENEFITS

- Maximised cut rate and cool grinding action on hardened or high-speed tool steels

## STARLINE GREEN SILICON CARBIDE



For all general purpose bench and pedestal applications on non-ferrous materials and carbide tools.

### FEATURES

- Sharp green silicon carbide
- Precision engineered grit sizes and hardness

### BENEFITS

- Maximised cut rate and finish on non-ferrous metals

A



### FEATURES

- Regular brown aluminium oxide abrasive
- Unique, self sharpening, microcrystalline structure

### BENEFITS

- Very tough, suitable for grinding most types of steel & soft iron
- Good cost/performance compromise
- Hard wearing wheels for general purpose cylindrical off-hand bench & pedestal grinding applications

39C



### FEATURES

- Highest purity green silicon carbide abrasive
- Harder & more friable than aluminium oxide abrasive

### BENEFITS

- Ideal for precision grinding & sharpening applications on metal carbide

ART. NO. With **VITRIUM** Revolutionary bond technology





# 38A



## FEATURES

- High purity white aluminium oxide abrasive
- Friable

## BENEFITS

- Cool & burn free cutting
- Ideal for heat-sensitive applications with light to moderate feed rates

## STARLINE - BROWN ALUMINIUM OXIDE

DIM DxTxH (mm)	SHAPE	MOS (m/s)	PK QTY	SPECIFICATION	ART. NO.	BEST/ BETTER/ GOOD
<b>■ ■ ■ SHAPE 01</b>						
125x20x32	01	45	2	A 46 N VS	66253289859	GOOD
125x20x32	01	45	2	A 60 N VS	66253289860	GOOD
150x20x32	01	45	2	A 46 N VS	66253289863	GOOD
150x20x32	01	45	2	A 60 N VS	66253290208	GOOD
	01	45	2	A 36 O VS	66253338141	GOOD
150x25x32	01	45	2	A 60 N VS	66253290209	GOOD
180x20x32	01	45	2	A 46 N VS	66253338021	GOOD
	01	45	2	A 60 N VS	66253338022	GOOD
200x20x32	01	45	2	A 46 N VS	66253338023	GOOD
	01	45	2	A 60 N VS	66253338024	GOOD
	01	45	2	A 36 O VS	66253338192	GOOD
200x25x32	01	45	2	A 60 N VS	66253195830	GOOD
	01	45	2	A 36 O VS	66253338025	GOOD
	01	45	2	A 46 N VS	66253338026	GOOD
250x32x32	01	45	1	A 46 N VS	66253289885	GOOD
	01	45	1	A 36 O VS	66253289887	GOOD
	01	45	1	A 60 N VS	66253338027	GOOD
300x32x32	01	45	1	A 36 O VS	66253289888	GOOD
	01	45	1	A 46 N VS	66253338029	GOOD
	01	45	1	A 60 N VS	66253338188	GOOD
300x40x127	01	45	1	A 46 N VS	66253289892	GOOD
	01	45	1	A 36 O VS	66253338031	GOOD
	01	45	1	A 60 N VS	66253338032	GOOD
350x50x127	01	45	1	A 46 N VS	66253338037	GOOD
	01	45	1	A 60 N VS	66253338038	GOOD
	01	45	1	A 36 O VS	66253338102	GOOD

**Dimensions Key:** DIM: Dimensions, D: Diameter, T: Thickness, H: Hole

**MOS:** Maximum Operating Speed,  
**PK QTY:** Packaging Quantity

All wheels with diameters 100mm-200mm and a 32mm bore are supplied with plastic bushes to reduce the bore size to 20mm. For a full range of plastic bushes please refer to the Application Section.

BONDED  
ABRASIVES

SUPER  
ABRASIVES

DIAMOND  
TOOLS

CLEANING,  
POLISHING  
& MASKING

PERSONAL  
PROTECTION  
EQUIPMENT

TECHNICAL  
INFORMATION

## STARLINE - WHITE ALUMINIUM OXIDE

DIM DxTxH (mm)	SHAPE	MOS (m/s)	PK QTY	SPECIFICATION	ART. NO.	BEST/ BETTER/ GOOD
<b>SHAPE 01</b>						
125x20x32	01	45	2	38A 46 N VS	66253289920	GOOD
	01	45	2	38A 60 N VS	66253338189	GOOD
150x20x32	01	45	2	38A 46 N VS	66253289922	GOOD
	01	45	2	38A 60 N VS	66253338090	GOOD
150x25x32	01	45	2	38A 60 N VS	66253338092	GOOD
180x20x32	01	45	2	38A 46 N VS	66253338093	GOOD
	01	45	2	38A 60 N VS	66253338094	GOOD
200x20x32	01	45	2	38A 46 N VS	66253338096	GOOD
	01	45	2	38A 60 N VS	66253338099	GOOD
200x25x32	01	45	2	38A 60 N VS	66253338065	GOOD
	01	45	2	38A 80 N VS	66253338066	GOOD
	01	45	2	38A 46 N VS	66253338142	GOOD
250x32x32	01	45	1	38A 46 N VS	66253338067	GOOD
	01	45	1	38A 60 N VS	66253338068	GOOD
300x32x32	01	45	1	38A 60 N VS	66253338069	GOOD
	01	45	1	38A 46 N VS	66253381592	GOOD
300x32x127	01	45	1	38A 46 N VS	66253338070	GOOD
350x50x127	01	45	1	38A 46 N VS	66253338072	GOOD
	01	45	1	38A 60 N VS	66253338073	GOOD

BONDED  
ABRASIVES

SUPER  
ABRASIVES

DIAMOND  
TOOLS

CLEANING,  
POLISHING  
& MASKING

PERSONAL  
PROTECTION  
EQUIPMENT

TECHNICAL  
INFORMATION

ART. NO. With **VITRIUM**  Revolutionary bond technology

## STARLINE - GREEN SILICON CARBIDE

DIM DxTxH (mm)	SHAPE	MOS (m/s)	PK QTY	SPECIFICATION	ART. NO.	BEST/ BETTER/ GOOD
<b>SHAPE 01</b>						
125x20x32	01	45	2	39C 60 K VS	66253338039	GOOD
	01	45	2	39C 80 K VS	66253338040	GOOD
150x20x32	01	45	2	38A 46 N VS	66253289922	GOOD
	01	45	2	39C 60 K VS	66253338041	GOOD
	01	45	2	39C 80 K VS	66253338042	GOOD
	01	45	2	39C 120 K VS	66253338191	GOOD
150x25x32	01	45	2	39C 60 K VS	66253338044	GOOD
180x20x32	01	45	2	39C 60 K VS	66253338045	GOOD
	01	45	2	39C 80 K VS	66253338050	GOOD
	01	45	2	38A 46 N VS	66253338093	GOOD
	01	45	2	39C 120 K VS	66253338184	GOOD
200x20x32	01	45	2	39C 46 K VS	66253338051	GOOD
	01	45	2	39C 60 K VS	66253338052	GOOD
	01	45	2	39C 80 K VS	66253338053	GOOD
	01	45	2	38A 46 N VS	66253338096	GOOD
	01	45	2	39C 120 K VS	66253338185	GOOD
200x25x32	01	45	2	39C 46 K VS	66253338054	GOOD
	01	45	2	39C 60 K VS	66253338055	GOOD
	01	45	2	39C 80 K VS	66253338056	GOOD
	01	45	2	38A 46 N VS	66253338142	GOOD
250x32x32	01	45	2	39C 46 K VS	66253338057	GOOD
	01	45	1	39C 60 K VS	66253338059	GOOD
	01	45	1	39C 80 K VS	66253338060	GOOD
	01	45	1	38A 46 N VS	66253338067	GOOD
300x32x32	01	45	1	39C 60 K VS	66253338074	GOOD
	01	45	1	39C 80 K VS	66253338075	GOOD
	01	45	1	38A 46 N VS	66253381592	GOOD
300x32x127	01	45	1	38A 46 N VS	66253338070	GOOD
300x40x127	01	45	1	39C 60 K VS	66253338077	GOOD
	01	45	1	39C 80 K VS	66253338078	GOOD
350x50x127	01	45	1	38A 46 N VS	66253338072	GOOD
	01	45	1	39C 46 K VS	66253338079	GOOD
	01	45	1	39C 60 K VS	66253338080	GOOD

**Dimensions Key:** DIM: Dimensions, D: Diameter, T: Thickness, H: Hole

**MOS:** Maximum Operating Speed,  
**PK QTY:** Packaging Quantity

BONDED  
ABRASIVES

SUPER  
ABRASIVES

DIAMOND  
TOOLS

CLEANING,  
POLISHING  
& MASKING

PERSONAL  
PROTECTION  
EQUIPMENT

TECHNICAL  
INFORMATION

## A - BROWN ALUMINIUM OXIDE

DIM DxTxH (mm)	SHAPE	MOS (m/s)	PK QTY	SPECIFICATION	ART. NO.	BEST/ BETTER/ GOOD
<b>SHAPE 01</b>						
125x16x20	01	35	5	A 60 K VBE	69210431641	GOOD
125x16x12,7	01	33	5	A 60 M VBE	69210434193	GOOD
125x20x20	01	35	4	A 60 M VBE	69210431647	GOOD
	01	45	2	A 46 O VS	69936640093	GOOD
125x20x32	01	45	2	A 60 N VS	69936666909	GOOD
	01	45	2	A 46 N VS	69936675558	GOOD
150x8x20	01	35	2	A 60 N VBE	69210431708	GOOD
150x10x20	01	35	2	A 60 N VBE	69210431698	GOOD
150x16x20	01	35	2	A 60 K VBE	69210431665	GOOD
150x16x32	01	45	2	A 46 N VS	69936675560	GOOD
150x16x12,7	01	45	2	A 60 M VBE	69083134410	GOOD
150x20x20	01	35	5	A 60 M VBE	69210431497	GOOD
	01	35	4	A 36 O VBE	69210434199	GOOD
150x20x32	01	45	2	A 36 P VS	69936638515	GOOD
	01	45	2	A 36 P VS	69936641366	GOOD
	01	45	2	A 60 N VS	69936641368	GOOD
150x20x12,7	01	35	5	A 60 M VBE	69210434201	GOOD
150x20x31,75	01	35	5	A 60 I VS	69936623302	GOOD
	01	35	2	A 46 N VS	69936623469	GOOD
	01	35	2	A 60 N VS	69936623470	GOOD
150x25x32	01	35	2	A 46 N VS	69936641370	GOOD
	01	45	2	A 60 N VS	69936641371	GOOD
	01	45	2	A 36 P VS	69936666914	GOOD
180x20x32	01	35	2	A 46 N VS	69936641372	GOOD
180x25x32	01	45	2	A 46 N VS	69936675564	GOOD
200x8x32	01	35	5	A 60 N VBE	69210431736	GOOD
200x10x32	01	35	5	A 60 N VBE	69210431740	GOOD
200x20x32	01	35	5	A 60 M VBE	69210431616	GOOD
	01	45	2	A 46 N VS	69936641375	GOOD
	01	45	2	A 60 N VS	69936666929	GOOD
	01	35	2	A 30 P VS	69936675566	GOOD
200x20x31,75	01	35	2	A 60 N VS	69936623591	GOOD
	01	50	2	A 46 N VS	69936623592	GOOD
200x25x32	01	45	2	A 36 Q VS	66253050267	GOOD
	01	45	2	A 46 M VS	66253050271	GOOD
	01	45	2	A 30 P VS	69936641382	GOOD
	01	45	2	A 36 P VS	69936641383	GOOD
200x25x32	01	35	2	A 24 R VS	69936676374	GOOD
200x25x31,75	01	35	2	A 36 P VS	69936623910	GOOD
	01	35	2	A 46 N VS	69936623911	GOOD
	01	35	2	A 60 N VS	69936623913	GOOD
200x25x76,2	01	45	2	A 46 N VS	69936675568	GOOD

ART. NO. With **VITRIUM** Revolutionary bond technology

## A - BROWN ALUMINIUM OXIDE

DIM DxTxH (mm)	SHAPE	MOS (m/s)	PK QTY	SPECIFICATION	ART. NO.	BEST/ BETTER/ GOOD
<b>SHAPE 01</b>						
200x32x32	01	35	5	A 60 M VBE	69210431655	GOOD
	01	45	2	A 36 P VBE	69210434317	GOOD
	01	45	2	A 46 N VS	69936640814	GOOD
	01	45	2	A 36 P VS	69936666932	GOOD
	01	45	2	A 60 N VS	69936690246	GOOD
250x8x32	01	63	6	A 60 N VBE	69210431587	GOOD
250x10x32	01	35	5	A 60 N VBE	69210431590	GOOD
250x25x32	01	35	1	A 60 K VBE	69210431552	GOOD
	01	45	1	A 46 N VS	69936641386	GOOD
250x25x31,75	01	35	1	A 36 O VS	69936623907	GOOD
	01	35	1	A 46 N VS	69936623914	GOOD
	01	50	1	A 60 N VS	69936623918	GOOD
250x32x32	01	45	1	A 60 M VS	69936642130	GOOD
	01	45	1	A 24 Q VS	69936666942	GOOD
	01	45	1	A 36 P VS	69936666943	GOOD
250x40x51	01	35	3	A 60 K VBE	69210431546	GOOD
300x32x32	01	35	1	A 36 O VS	69936675575	GOOD
	01	35	1	A 46 N VS	69936675576	GOOD
300x32x127	01	45	1	A 24 Q VS	69936675579	GOOD
	01	45	1	A 36 O VS	69936675580	GOOD
	01	45	1	A 46 N VS	69936675581	GOOD
300x40x32	01	45	1	A 46 N VS	69936639682	GOOD
	01	45	1	A 60 M VS	69936640221	GOOD
300x40x51	01	35	3	A 60 K VBE	69210431562	GOOD
300x40x127	01	45	1	A 24 Q VS	69936675583	GOOD
	01	45	1	A 36 O VS	69936675584	GOOD
	01	45	1	A 46 N VS	69936675585	GOOD
300x40x31,75	01	35	1	A 36 O VS	69936623686	GOOD
	01	35	1	A 46 N VS	69936623703	GOOD
300x40x31,75	01	45	1	A 60 N VS	69936623724	GOOD
300x50x32	01	45	1	A 60 N VS	66243570484	GOOD
	01	45	1	A 36 O VS	69936681823	GOOD
350x40x127	01	35	3	A 60 K VBE	69210431569	GOOD
355x40x127	01	45	1	A 24 Q VS	69936675586	GOOD
	01	45	1	A 46 N VS	69936675587	GOOD
355x50x127	01	45	1	A 24 Q VS	69936675588	GOOD
	01	35	1	A 36 O VS	69936675589	GOOD
355x50x31,75	01	35	1	A 60 N VS	69936623742	GOOD
406x50x50	01	50	1	A 24 Q VS	66243448177	GOOD
406x50x127	01	45	1	A 24 Q VS	66243467496	GOOD
	01	35	1	A 36 O VS	66243467497	GOOD

BONDED  
ABRASIVES

SUPER  
ABRASIVES

DIAMOND  
TOOLS

CLEANING,  
POLISHING  
& MASKING

PERSONAL  
PROTECTION  
EQUIPMENT



TECHNICAL  
INFORMATION

Dimensions Key: DIM: Dimensions, D: Diameter, T: Thickness, H: Hole

MOS: Maximum Operating Speed,  
PK QTY: Packaging Quantity



## 38A - WHITE ALUMINIUM OXIDE

DIM DxTxH (mm)	SHAPE	MOS (m/s)	PK QTY	SPECIFICATION	ART. NO.	BEST/ BETTER/ GOOD
	 SHAPE 01					
	 SHAPE 05					
125x16x32	01	45	2	38A 60 M VS	66253050237	GOOD
125x20x20	01	35	5	38A 60 K VBE	69210431173	GOOD
125x20x32	01	32	4	38A 60 L VS	69936675736	GOOD
150x20x20	01	35	4	38A 46 M VS	69936639373	GOOD
150x20x32	01	45	2	38A 60 N VS	69936641392	GOOD
150x25x20	01	35	4	38A 60 M VS	69936639805	GOOD
180x20x32	01	45	2	38A 60 L VS	69936641395	GOOD
180x20x31,75	01	35	2	38A 46 L VS	69936623312	GOOD
	01	35	2	38A 60 L VS	69936623472	GOOD
180x25x32	01	63	2	38A 60 L VS	69936675812	GOOD
180x25x31,75	05	63	2	38A 60 K VS3	66253354035	BETTER
	05	50	2	38A 46 K VS3	66253354036	BETTER
	05	35	2	38A 60 L VS	69936621526	GOOD
200x20x32	01	45	2	38A 46 K VS	66253051075	GOOD
	01	45	2	38A 60 K VS	66253051077	GOOD
	01	45	2	38A 80 K VS	66253051080	GOOD
	01	45	2	38A 46 K VS	69936640300	GOOD
	01	35	2	38A 46 N VS	69936641400	GOOD
	01	45	2	38A 60 L VS	69936641402	GOOD
200x20x32	01	45	2	38A 60 N VS	69936667154	GOOD
200x20x31,75	01	63	2	38A 60 K VS3	66253354038	BETTER
	01	35	2	38A 46 K VS3	66253354039	BETTER
200x20x50,8	01	45	2	38A 60 K VS	66253049967	GOOD
200x20x50,8	01	45	2	38A 46 J VS	69936675832	GOOD
200x25x20	01	35	4	38A 60 K VBE	69210432867	GOOD
	01	35	2	38A 60 M VS	69936641405	GOOD
200x25x32	01	45	2	38A 60 M VS	66253051079	GOOD
	01	45	2	38A 80 K VS	66253051082	GOOD
	01	35	4	38A 46 L VS	69936627127	GOOD
	01	45	2	38A 60 M VS	69936639846	GOOD
	01	45	2	38A 46 N VS	69936641406	GOOD
	01	45	2	38A 60 L VS	69936641407	GOOD
	01	45	2	38A 80 N VS	69936675847	GOOD
200x25x31,75	01	35	2	38A 60 L VS	69936623794	GOOD
200x25x76,2	01	35	2	38A 46 N VS	69936675841	GOOD
	01	45	2	38A 60 N VS	69936675846	GOOD
200x32x32	01	35	5	38A 46 M VS	66253052712	GOOD
	01	45	2	38A 60 L VS	69936675855	GOOD
200x32x76,2	01	35	2	38A 46 N VS	69936675849	GOOD

BONDED ABRASIVES

SUPER ABRASIVES

DIAMOND TOOLS

CLEANING, POLISHING & MASKING

PERSONAL PROTECTION EQUIPMENT

TECHNICAL INFORMATION

ART. NO. With **VITRIUM**  Revolutionary bond technology

## 38A - WHITE ALUMINIUM OXIDE

DIM DxTxH (mm)	SHAPE	MOS (m/s)	PK QTY	SPECIFICATION	ART. NO.	BEST/ BETTER/ GOOD
<b>SHAPE 01</b>						
250x20x32	01	35	5	38A 60 L VS3	69210431009	BETTER
250x25x32	01	45	1	38A 60 L VS	66253049927	GOOD
	01	35	5	38A 46 L VS3	69210431034	BETTER
	01	45	1	38A 60 M VS	69936639356	GOOD
	01	35	3	38A 60 N VS	69936667158	GOOD
	01	45	1	38A 60 K VS	66253051100	GOOD
300x32x32	01	45	1	38A 60 N VS	69936639618	GOOD

**Dimensions Key:** DIM: Dimensions, D: Diameter, T: Thickness, H: Hole

MOS: Maximum Operating Speed,  
PK QTY: Packaging Quantity

BONDED  
ABRASIVES

SUPER  
ABRASIVES

DIAMOND  
TOOLS

CLEANING,  
POLISHING  
& MASKING

PERSONAL  
PROTECTION  
EQUIPMENT

TECHNICAL  
INFORMATION

## 39C - GREEN SILICON CARBIDE

DIM DxTxH (mm)	SHAPE	MOS (m/s)	PK QTY	SPECIFICATION	ART. NO.	BEST/ BETTER/ GOOD
<b>■ ■ ■ SHAPE 01</b>						
125x16x32	01	33	5	39C 80 L VS	66253050393	GOOD
125x20x20	01	35	4	39C 80 K VS	69936639669	GOOD
125x20x32	01	45	2	39C 80 L VS	69936667443	GOOD
150x16x20	01	35	2	39C 80 K VS	69936641095	GOOD
150x20x20	01	35	5	39C 60 K VK	69210431294	GOOD
	01	35	5	39C 60 J VK	69210432298	GOOD
	01	35	4	39C 100 J VS	69936640003	GOOD
	01	35	4	39C 80 K VS	69936641410	GOOD
150x20x32	01	45	2	39C 60 K VS	69936641411	GOOD
	01	45	2	39C 80 L VS	69936641413	GOOD
	01	35	2	39C 120 K VS	69936641414	GOOD
150x20x31,75	01	35	5	39C 100 K VS	69936623221	GOOD
	01	35	4	39C 60 K VS	69936623474	GOOD
150x25x20	01	45	2	39C 80 K VS	69936641429	GOOD
150x25x32	01	45	2	39C 80 K VS	66253050278	GOOD
	01	45	2	39C 60 K VS	69936675661	GOOD
	01	35	2	39C 120 K VS	69936675664	GOOD
175x20x32	01	45	2	39C 60 J VK	69210434205	GOOD
180x20x32	01	45	2	39C 60 K VS	69936641415	GOOD
	01	45	2	39C 120 K VS	69936675666	GOOD
	01	50	2	39C 80 L VS	69936676582	GOOD
180x20x31,75	01	50	2	39C 60 K VS	69936623477	GOOD
180x25x32	01	45	2	39C 80 L VS	69936667101	GOOD
	01	45	2	39C 60 K VS	69936675667	GOOD
200x20x20	01	45	2	39C 100 J VS	69936639897	GOOD
	01	45	2	39C 80 M VS	69936640220	GOOD
	01	35	4	39C 80 K VS	69936641417	GOOD
200x20x32	01	45	5	39C 60 K VK	69210431384	GOOD
	01	35	5	39C 80 K VK	69210431685	GOOD
	01	35	2	39C 60 K VS	69936641418	GOOD
	01	45	2	39C 80 L VS	69936641420	GOOD
	01	45	2	39C 120 K VS	69936641421	GOOD
	01	45	2	39C 80 K VS	69936676351	GOOD
200x20x51	01	35	2	39C 60 K VS	69936640176	GOOD
200x25x20	01	45	2	39C 80 K VS	69936641422	GOOD

BONDED  
ABRASIVES

SUPER  
ABRASIVES

DIAMOND  
TOOLS

CLEANING,  
POLISHING  
& MASKING

PERSONAL  
PROTECTION  
EQUIPMENT

TECHNICAL  
INFORMATION

ART. NO. With **VITRIUM**  Revolutionary bond technology

## 39C - GREEN SILICON CARBIDE

DIM DxTxH (mm)	SHAPE	MOS (m/s)	PK QTY	SPECIFICATION	ART. NO.	BEST/ BETTER/ GOOD
	SHAPE 01					
	SHAPE 05					
200x25x32	01	45	2	39C 80 K VS	66253050276	GOOD
	01	35	5	39C 60 K VK	69210431399	GOOD
	01	35	2	39C 60 K VS	69936641424	GOOD
	01	45	2	39C 80 L VS	69936641427	GOOD
	01	45	2	39C 120 K VS	69936641428	GOOD
	01	35	2	39C 46 L VS	69936675639	GOOD
200x25x31,75	01	35	2	39C 100 K VS	69936623599	GOOD
	01	35	2	39C 60 K VS	69936623912	GOOD
200x32x32	01	45	2	39C 60 K VS	69936640293	GOOD
	01	45	2	39C 80 K VS	69936667106	GOOD
	01	45	2	39C 120 K VS	69936675677	GOOD
200x40x20	05	45	2	39C 80 J VS	69936640285	GOOD
230x25x32	01	45	2	39C 80 K VS	69936639374	GOOD
250x25x32	01	35	5	39C 60 K VK	69210431068	GOOD
	01	35	5	39C 80 L VS	69936675679	GOOD
250x25x31,75	01	35	1	39C 60 K VS	69936623664	GOOD
250x32x32	01	45	1	39C 60 K VS	69936639837	GOOD
	01	45	1	39C 80 K VS	69936640845	GOOD
300x32x32	01	35	3	39C 60 K VK	69210431036	GOOD
300x40x32	01	45	1	39C 60 K VS	69936639362	GOOD
	01	35	3	39C 80 K VS	69936676387	GOOD
300x40x31,75	01	35	1	39C 60 L VS	69936623682	GOOD

**Dimensions Key:** DIM: Dimensions, D: Diameter, T: Thickness, H: Hole

**MOS:** Maximum Operating Speed,  
**PK QTY:** Packaging Quantity

BONDED  
ABRASIVES

SUPER  
ABRASIVES

DIAMOND  
TOOLS

CLEANING,  
POLISHING  
& MASKING

PERSONAL  
PROTECTION  
EQUIPMENT

TECHNICAL  
INFORMATION

# MOUNTED POINTS & WHEELS

Norton Quantum (NQ) vitrified mounted points are the best, versatile choice for high volume Foundry and Aerospace operations. The unique, engineered ceramic grain shape in combination with the chemistry of the proven bond technology can provide 33%+ longer life versus competitive ceramic products with 30%+ higher metal removal rates. With minimal loading and heat build-up they are ideal for grinding Inconel and similar alloy turbine blade components, e.g. to attain final geometry and to create a uniform finish. Less pressure is needed to get optimum performance so... **Let the Norton Quantum grain do the work!**

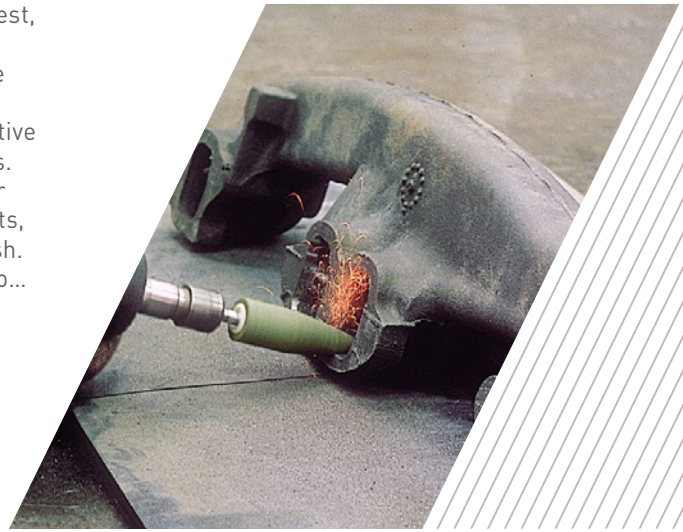

## APPLICATIONS & MARKETS

- Deburring
- Blending
- Finishing

BONDED  
ABRASIVES

SUPER  
ABRASIVES

DIAMOND  
TOOLS

CLEANING,  
POLISHING  
& MASKING

PERSONAL  
PROTECTION  
EQUIPMENT

TECHNICAL  
INFORMATION

## NORTON QUANTUM NQ

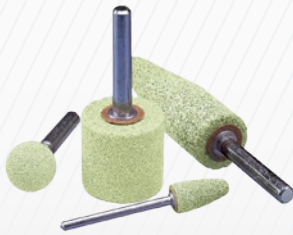

### FEATURES

- Unique, engineered ceramic grain shape and chemistry with proven bond technology

BEST +++++



### BENEFITS

- Ideal for high-volume foundry operations – grinding Inconel and similar alloy turbine blade components
- Minimal loading and heat build-up
- 33%+ longer life vs. competitive ceramic products
- 30%+ higher metal removal rates
- Versatile, optimized for all low, medium and high force applications
- Exceptional productivity and life

## 86A

GOOD +++



### FEATURES

- Highly refined pink aluminium oxide abrasive
- Tougher than pure white aluminium oxide abrasive
- Good profile holding
- Contains a small portion of chromium oxide abrasive

### BENEFITS

- Very versatile
- Reduced dress frequency
- Better part geometry



## MOUNTED POINTS SHAPE A

SHAPE	DIM DIAxL (mm)	SPINDLE DIAxL (mm)	MOS (RPM)	PK QTY	BEST		GOOD	
A1	20x65	6x40	15000	10	3NQ 80-OVQN	61463688951	86A 36 PVS	66253055235
	20x65	6x40	15000	10			86A 60 PVS	66253055218
A3	22x70	6x40	14000	10			86A 30 PVS	66253055021
	22x70	6x40	14000	10			86A 60 PVS	66253055212
A5	20x28	6x40	30000	10	3NQ 80-OVQN	61463688954	86A 60 PVS	66253055094
A7	30x50	6x40	13000	10			86A 30 PVS	66253055022
A8	20x50	6x40	18000	10			86A 36 PVS	66253055308
A9	30x50	6x40	13000	10			86A 30 PVS	66253055395
A10	22x70	6x40	14000	10			86A 36 PVS	66253055237
A11	21x45	6x40	18000	10	3NQ 80-OVQN	61463620969	86A 30 PVS	66253055307
	21x45	6x40	18000	10			86A 36 PVS	66253055095
	21x45	6x40	18000	10			86A 60 PVS	66253055214
A12	18x30	6x40	30000	10			86A 60 PVS	66253055096
A15	6x25	6x40	30000	10			86A 90 PVS	66253055126
A19	30x50	6x40	13000	10			86A 60 PVS	66253054961
A21	25x25	6x40	25000	10	3NQ 80-OVQN	61463688956		
A23	20x25	6x40	25000	10	3NQ 80-OVQN	61463689937		
A24	6x20	6x40	41000	10			86A 60 PVS	66253055127
A25	25x25	6x40	25000	10			86A 60 PVS	66253055128
A26	16x16	6x40	54000	10	3NQ 80-OVQN	61463688957	86A 46 PVS	66253055204
A36	40x10	6x40	25000	10	3NQ 80-OVQN	61463688960	86A 60 PVS	66253055129
A37	30x6	6x40	30000	10			86A 90 PVS	66253055313
A38	25x25	6x40	25000	10			86A 60 PVS	66253054946
A39	20x20	6x41	25000	10	3NQ 80-OVQN	61463689938		

## MOUNTED POINTS SHAPE B

SHAPE	DIM DIAxL (mm)	SPINDLE DIAxL (mm)	MOS (RPM)	PK QTY	BEST		GOOD	
B44	6x10	3x40	61000	10			86A 90 PVS	66253055183
B52	10x20	3x40	41000	10	3NQ 80-OVQN	61463688963	86A 90 PVS	66253055232
B53	6x16	3x40	54000	10			86A 90 PVS	66253055305
B54	6x13	3x40	54000	10			86A 90 PVS	66253055139
B81	20x4	3x40	47000	10			86A 90 PVS	66253055140
B91	13x16	3x40	58000	10			86A 90 PVS	66253055199
B97	3x10	3x40	90000	10	3NQ 80-OVQN	61463688964	86A 90 PVS	66253055141
B121	13x13	3x40	58000	10			86A 90 PVS	66253055143
B122	10x3	3x40	58000	10	3NQ 80-OVQN	61463688965		
B123	5x5	3x40	73000	10			86A 90 PVS	66253055207
B131	13x13	3x40	58000	10	3NQ 80-OVQN	61463689939		

**Dimensions Key:** DIM = Dimensions, DIA = Diameter, L = Length

BONDED ABRASIVES

SUPER ABRASIVES

DIAMOND TOOLS

CLEANING, POLISHING & MASKING

PERSONAL PROTECTION EQUIPMENT

TECHNICAL INFORMATION

## SHAPE A KEY

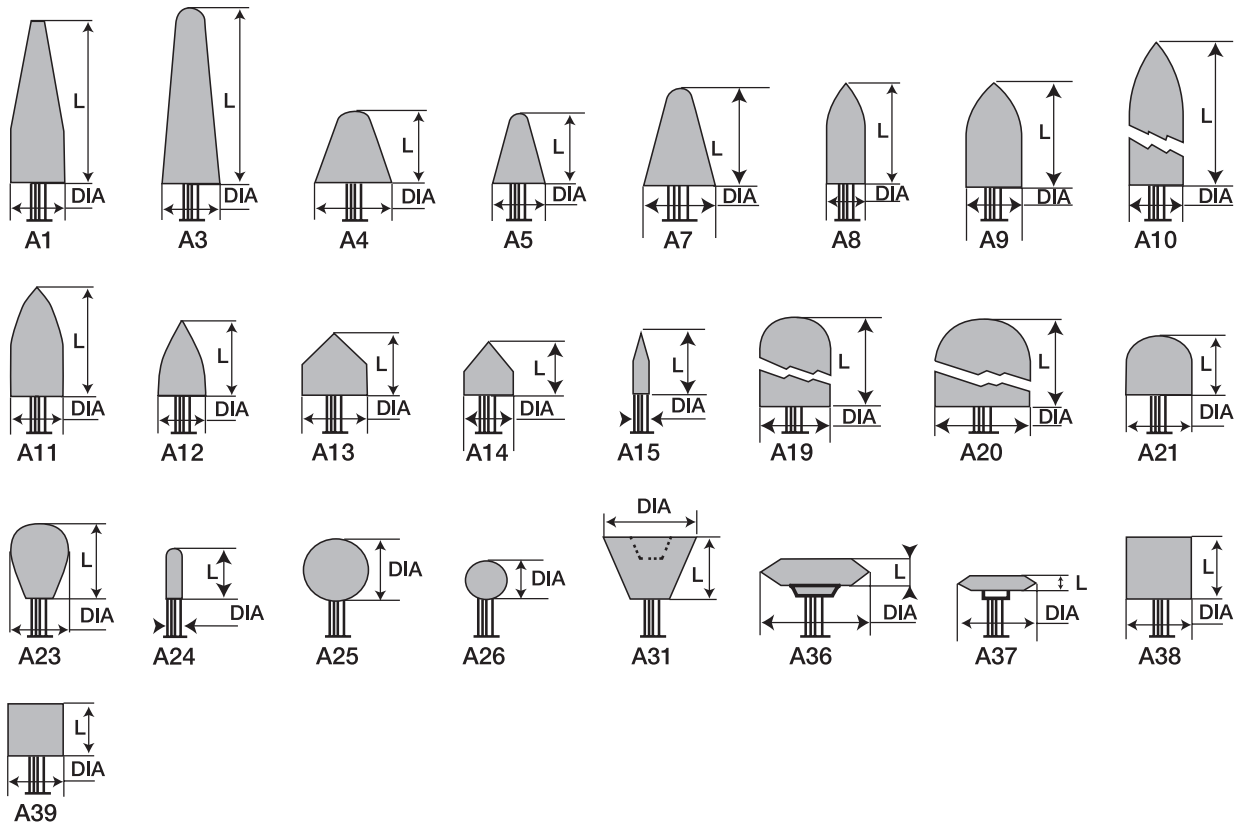

## SHAPE B KEY

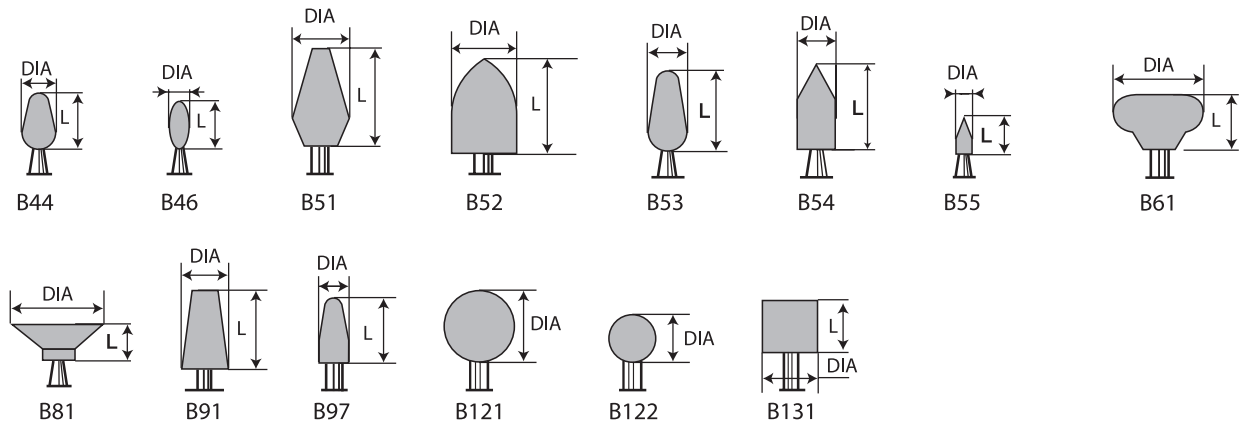

## SHAPE C KEY

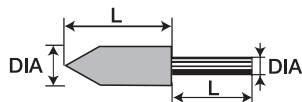

## SHAPE W KEY

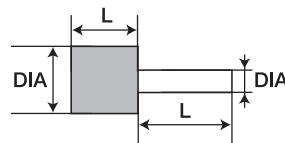

## MOUNTED WHEELS

SHAPE	DIM DIAxL (mm)	SPINDLE DIAxL (mm)	MOS (RPM)	PK QTY	BEST		GOOD	
W144	3x6	3x40	90000	10			86A 90 PVS	66253055147
W149	4x6	3x40	80000	10			86A 90 PVS	66253055150
W153	5x10	3x40	73000	10			86A 90 PVS	66253055160
W154	5x13	3x40	70000	10	3NQ 80-OVQN	61463688966	86A 90 PVS	66253055162
W162	6x10	3x40	61000	10			86A 60 PVS	66253055166
	6x10	3x40	61000	10			86A 90 PVS	66253055206
W163	6x13	6x40	54000	10			86A 60 PVS	66253055210
	6x13	3x40	54000	10			86A 90 PVS	66253055167
W164	6x20	3x40	41000	10	3NQ 80-OVQN	61463688967		
W169	8x10	3x40	61000	10			86A 60 PVS	66253055398
W170	8x13	6x40	54000	10			86A 60 PVS	66253055248
W171	8x20	3x40	41000	10			86A 60 PVS	66253055171
W175	10x10	3x40	61000	10			86A 90 PVS	66253055173
W176	10x13	6x40	54000	10			86A 60 PVS	66253055315
W177	10x20	6x40	41000	10			86A 60 PVS	66253055092
W179	10x32	6x40	25000	10			86A 60 PVS	66253055223
W185	13x13	6x40	58000	10	3NQ 80-OVQN	61463688969		
W188	13x40	6x40	20000	10			86A 90 PVS	66253055131
W195	16x20	6x40	47000	10			86A 60 PVS	66253055091
W196	16x25	6x40	35000	10			86A 90 PVS	66253054973
W204	20x20	6x40	42000	10			86A 60 PVS	66253055134
W205	20x25	6x40	32000	10			86A 36 PVS	66253054948
	20x25	6x40	32000	10			86A 60 PVS	66253055135
W206	20x32	6x40	30000	10			86A 60 PVS	66253055013
W215	25x3	3x40	38000	10	3NQ 80-OVQN	61463688973		
W220	25x25	6x40	25000	10			86A 36 PVS	66253055231
	25x25	6x40	25000	10			86A 60 PVS	66253055136
W221	25x40	6x40	19000	10			86A 36 PVS	66253055016
W230	32x32	6x40	17000	10			86A 36 PVS	66253055221
	32x32	6x40	17000	10			86A 60 PVS	66253055138
W232	32x50	6x40	11000	10			86A 60 PVS	66253055300
W236	40x13	6x40	25000	10			86A 60 PVS	66253055304
W238	40x40	6x40	12000	10			86A 36 PVS	66253055019
	40x40	6x40	12000	10			86A 60 PVS	66253055065

**Dimensions Key:** DIM = Dimensions, DIA = Diameter, L = Length

BONDED ABRASIVES

SUPER ABRASIVES

DIAMOND TOOLS

CLEANING, POLISHING & MASKING

PERSONAL PROTECTION EQUIPMENT

TECHNICAL INFORMATION

## MOUNTED POINT KITS

TYPE	STYLE	STYLE	KIT CONTENTS PER SHAPE	ART. NO.
Norton Quantum A Assorted	6mm spindle dia	1 pc each in card headed plastic bag	A1, A5, A11, A21, A23, A26, A36, A39, W242 Norton Quantum (and BF3 W220 A80-HBF3 - for polishing scratches from NQ)	61463692247
Norton Quantum B Assorted	3mm spindle dia	1 pc each in card headed plastic bag	B42, B52, B97, B122, B131, W154, W164, W185, W215 Norton Quantum (and BF3 W163 A80-HBF3 - for polishing scratches from NQ)	61463692248
NZ	6mm spindle dia	1 pc each in card headed plastic bag	A1, A3, A5, A11, W220, NZ24	66253145961

BONDED ABRASIVES

SUPER ABRASIVES

DIAMOND TOOLS

CLEANING, POLISHING & MASKING

PERSONAL PROTECTION EQUIPMENT

TECHNICAL INFORMATION



### SPEC CHECK

- Use 36 grit & coarser for rough grinding
- Use 60 grit for imparting fine finishes or when grinding on narrow surfaces



# DRESSING STICKS

Regular use of properly selected dressing sticks will help you achieve maximum performance from your vitrified wheels.

## APPLICATIONS & MARKETS

- Truing, cleaning & dressing Diamond, CBN & conventional abrasive wheels



## NORBIDE

**BEST +++++**



### FEATURES

- Manufactured from sintered boron carbide
- Extremely hard & very dense

### BENEFITS

- Excellent chemical & wear resistance
- Long product life, reduced maintenance & less downtime
- Suitable also for dressing tool & cutter wheels 200mm & smaller, especially cup & dish shapes

## 39C

**BETTER ++++**



### FEATURES

- Highest purity green silicon carbide abrasive
- Harder & more friable than aluminium oxide abrasive

### BENEFITS

- Ideal for dressing conventional vitrified grinding wheels
- Outperforms 37C for better cutting efficiency & longer life

BONDED ABRASIVES

SUPER ABRASIVES

DIAMOND TOOLS

CLEANING, POLISHING & MASKING

PERSONAL PROTECTION EQUIPMENT

TECHNICAL INFORMATION



# 38A

GOOD +++



### FEATURES

- High purity white aluminium oxide abrasive
- Friable abrasive

### BENEFITS

- Ideal for dressing CBN Super Abrasive wheels

# 37C





### FEATURES

- High purity black silicon carbide abrasive
- Harder & more friable than aluminium oxide abrasive



### BENEFITS

- Ideal for dressing conventional vitrified grinding wheels

## DRESSING STICKS FOR SUPER ABRASIVE GRINDING WHEELS

DIM (mm)	PK QTY	GOOD	
<b>RECTANGULAR</b>			
WxHxL 			
13x25x150	10	38A 150 HVBE	61463605565
	10	38A 220 HVBE	61463605066
	10	38A 320 HVBE	69936684889
<b>SQUARE</b>			
WxHxL 			
13x13x150	10	37C 80 MV	69936685063
	10	38A 220 HVS	69936682631
	10	38A 150 IVBE	69936682314
	10	37C 320 HV	66243453547
20x20x150	10	38A 150 HVBE	69936685064
	10	38A 220 IVBE	61463603606

## DRESSING STICKS FOR BONDED ABRASIVE GRINDING WHEELS

DIM (mm)	PK QTY	GOOD	
<b>RECTANGULAR</b> 			
WxHxL			
5x12,7x76,2	1	NORBIDE	61463610148
25x50x200	10	37C 24 TV	69936685072
<b>SQUARE</b> 			
WxHxL			
25x25x150	10	37C 30 UV	69936624620
<b>ROUND</b> 			
DIAxL			
25,4x203,2	10	37C 30 TV	61463625024

## GENERAL PURPOSE DRESSING STICKS

DIM (mm)	PK QTY	GOOD	
<b>RECTANGULAR</b> 			
WxHxL			
13x25x150	10	38A 220 KV	66243460886
25x50x200	10	39C 60 KV	69936685066

**Dimensions Key:** DIM = Dimensions, DIA = Diameter, W = Width, H = Height, L = Length



### SPEC CHECK

- Use 38A dressing sticks to dress CBN wheels
- Use 37C dressing sticks to dress Diamond wheels.

BONDED ABRASIVES

SUPER ABRASIVES

DIAMOND TOOLS

CLEANING, POLISHING & MASKING

PERSONAL PROTECTION EQUIPMENT

TECHNICAL INFORMATION

# BENCH & COMBINATION OIL STONES

Since 1823, Norton has been the leading supplier of benchstones, files, slips and rubbing bricks. Our comprehensive line of sharpening and finishing stones delivers superior performance solutions.

## APPLICATIONS & MARKETS

- Chisels
- Wood lathe cutters
- Knives
- Plane blades
- Precision tools & delicate instruments



BONDED  
ABRASIVES

SUPER  
ABRASIVES

DIAMOND  
TOOLS

CLEANING,  
POLISHING  
& MASKING

PERSONAL  
PROTECTION  
EQUIPMENT

TECHNICAL  
INFORMATION

## CRYSTOLON

GOOD +++

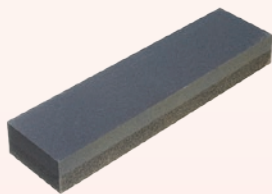

### FEATURES

- Premium silicon carbide abrasive
- Pre-filled with oil

### BENEFITS

- Fast cutting stone; ideal for general sharpening of cutting tools
- Fast stock removal for quick edge shaping with minimal loading
- Saves time by eliminating the need for pre-soaking prior to use

## INDIA



### FEATURES

- Smooth cutting aluminium oxide abrasive
- Norton's trademark for a fine finish
- Pre-filled with oil

### BENEFITS

- Long lasting cutting edge
- Ideal for cleaning, deburring & good quality finishes
- Saves time by eliminating the need for pre-soaking prior to use

## ARKANSAS



### FEATURES

- Natural premium Novaculite quarried in Arkansas & available in soft & hard
- Dense construction

### BENEFITS

- Sharpest possible razor edges
- Near mirror finishes
- Use for finer honing after India stone
- Absorbs oil at a slower rate, hence does not require pre-filling

## PRODUCT SELECTION

APPLICATION	COARSE / MEDIUM SHARPENING	FINE STONING
Carbide tool	Medium & coarse Crystolon Bench	Fine Crystolon Bench
	Coarse/fine Crystolon Combination	Coarse/fine Crystolon Combination
Steel tool	Medium & coarse India Bench	Fine India Bench
	Coarse/fine India Combination	Coarse/fine India Combination

## BENCH & COMBINATION OIL STONES

DIM (mm)    TYPE    PK QTY

GOOD

**BENCH STONES**  
LxWxH



102x25x6	MB14	5	Medium India	61463685575
	FB14	5	Fine India	61463685570
102x25x10	HB14	5	Hard Arkansas	61463687555
	SB14	5	Soft Arkansas	61463687565
102x25x13	CB24	5	Coarse India	61463685595
	MB24	5	Medium India	61463685590
	MJB24	5	Medium Crystolon	61463685480
	FB24	5	Fine India	61463685585
102x44x13	MB124	5	Medium India	61463626048
152x38x13	MB26	5	Medium India	61463626034
152x51x19	HB6	5	Hard Arkansas	61463685660
	UPB6	10	Medium India	61463690694
152x51x25	CB6	5	Coarse India	61463685620
	MB6	5	Medium India	61463685615
	MJB6	5	Medium Crystolon	61463685505
	FB6	5	Fine India	61463685610
	FJB6	5	Fine Crystolon	61463685500
203x51x25	CB8	5	Coarse India	61463685635
	UPB8	5	Medium India	61463685755
	MB8	5	Medium India	61463685630
	FB8	5	Fine India	61463685625

**Dimensions Key:** DIM = Dimensions, L = Length, W = Width, H = Height

BONDED ABRASIVES

SUPER ABRASIVES

DIAMOND TOOLS

CLEANING, POLISHING & MASKING

PERSONAL PROTECTION EQUIPMENT

TECHNICAL INFORMATION

**COMBINATION OIL STONES**

LxWxH



102x25x13	IB24	5	Coarse/Fine India	61463626001
102x44x16	JB134	5	Coarse/Fine Crystolon	61463685440
	IB134	5	Coarse/Fine India	61463685550
127x51x19	JB45	5	Coarse/Fine Crystolon	61463685445
	IB45	5	Coarse/Fine India	61463685555
152x51x25	JB6	5	Coarse/Fine Crystolon	61463685450
	IB6	5	Coarse/Fine India	61463685560
152x64x25	IB20	5	Coarse/Fine India	61463626103
178x51x25	IB7	5	Coarse/Fine India	61463690647
203x51x25	JB8	5	Coarse/Fine Crystolon	61463685455
	IB8	5	Coarse/Fine India	61463625078

**Dimensions Key:** DIM = Dimensions, L = Length, W = Width, H = Height





# ABRASIVE & PRECISION FILES

Norton abrasive files hold their shape while imparting the finest, most uniform finish on precision machine parts, and in tool and die making.

## APPLICATIONS & MARKETS

- Deburring
- Chamfering
- RADIUSING



## CRYSTOLON

GOOD +++

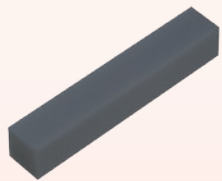

### FEATURES

- Premium silicon carbide abrasive

### BENEFITS

- Fast cutting
- Ideal for general sharpening

## INDIA



### FEATURES

- Smooth cutting aluminium oxide abrasive

### BENEFITS

- Ideal when a close tolerance is more important than the speed of cut

## ARKANSAS



### FEATURES

- Hard Novaculite abrasive quarried in Arkansas

### BENEFITS

- Produces the finest edge possible while maintaining tolerances unequalled by any other abrasive
- Produces a highly polished finish

BONDED  
ABRASIVES

SUPER  
ABRASIVES

DIAMOND  
TOOLS

CLEANING,  
POLISHING  
& MASKING

PERSONAL  
PROTECTION  
EQUIPMENT

TECHNICAL  
INFORMATION

## PRODUCT SELECTION

APPLICATION	COARSE / MEDIUM SHARPENING	FINE STONING	FINISH HONING
Carbide tool	Medium Crystolon square		
Centre punches	Medium India triangle	Fine India triangle	
Countersinks	Coarse/medium India triangle	Fine India triangle	Hard Arkansas triangle
Form cutter	Coarse/medium India knife blade	Fine India knife blade	Hard Arkansas knife blade
Keyways	Coarse/medium India square	Fine India square	Hard Arkansas square
Lathe bits		Fine India square	Hard Arkansas square
Machine knife stone	Coarse Crystolon machine knife		
Magnetic chucks		India round	
Pointed	Medium India pointed		Hard Arkansas pointed
Precision machine knife	Medium India half round	Fine India half round	
Radius tools	Medium India round	Fine India round	Hard Arkansas round
Router bits		Fine India square	
Silversmith	Medium India Silversmith	Fine India Silversmith	
Tap threads		Fine India triangle	

## ABRASIVE FILES

DIM  
(mm)

TYPE

PK  
QTY

GOOD

### ROUND

LxDIA



76x6	HF813	5	Hard Arkansas	61463686800
102x3	FF212	5	Fine India	61463626076
102x6	MF214	5	Medium India	61463686475
	FF214	5	Fine India	61463686470
102x10	MF234	5	Medium India	61463686490
	FF234	5	Fine India	61463686485
102x13	MF244	5	Medium India	61463686505
	FF244	5	Fine India	61463686500
152x10	FF236	5	Fine India	61463626106
152x13	MF246	5	Medium India	61463686520
	FF246	5	Fine India	61463686515
152x16	MF256	5	Medium India	61463686535
	FF256	5	Fine India	61463686530
152x19	MF266	5	Medium India	61463686550

### HALF ROUND

LxH



102x10	MF334	5	Medium India	61463686385
102x13	MF344	5	Medium India	61463686400
	FF344	5	Fine India	61463686395

### SQUARE

LxH



76x6	HF13	5	Hard Arkansas	61463686590
76x10	HF33	5	Hard Arkansas	61463686595
76x13	HF43	5	Hard Arkansas	61463686600
102x6	FF14	5	Fine India	61463686065
	MF14	5	Medium India	61463686070
102x8	MF24	5	Medium India	61463626072
102x10	FF34	5	Fine India	61463686080
	MF34	5	Medium India	61463686085
	CF34	5	Coarse India	61463686090
102x13	CF44	5	Coarse India	61463686105
	FF44	5	Fine India	61463686095
	MF44	5	Medium India	61463686100
152x10	FF36	5	Fine India	61463626037
	MF36	5	Medium India	61463626038
152x13	FF46	5	Fine India	61463686110
	MF46	5	Medium India	61463686115
152x16	FF56	5	Fine India	61463686125
	MF56	5	Medium India	61463686130
152x19	CF66	5	Coarse India	61463686150
	FF66	5	Fine India	61463686140
	MF66	5	Medium India	61463686145
152x25	FF76	5	Fine India	61463686155
	MJF76	5	Medium Crystolon	61463625039

**Dimensions Key:** DIM = Dimensions, L = Length, DIA = Diameter, H = Height

BONDED  
ABRASIVES

SUPER  
ABRASIVES

DIAMOND  
TOOLS

CLEANING,  
POLISHING  
& MASKING

PERSONAL  
PROTECTION  
EQUIPMENT

TECHNICAL  
INFORMATION

## ABRASIVE FILES

### TRIANGLE

LxH



76x6	HF113	5	Hard Arkansas	61463686620
76x10	HF133	5	Hard Arkansas	61463686625
76x13	HF143	5	Hard Arkansas	61463686630
102x6	MF114	5	Medium India	61463686235
	FF114	5	Fine India	61463686230
	CF114	5	Coarse India	61463686240
102x8	MF124	5	Medium India	61463626027
	FF124	5	Fine India	61463626028
102x10	MF134	5	Medium India	61463686250
	FF134	5	Fine India	61463686245
102x13	CF144	5	Coarse India	61463686270
	MF144	5	Medium India	61463686265
	FF144	5	Fine India	61463686260
152x10	MF136	5	Medium India	61463626090
	FF136	5	Fine India	61463626054
152x13	MF146	5	Medium India	61463686280
	MJF146	5	Medium Crystolon	61463625043
	FF146	5	Fine India	61463686275
152x16	MF156	5	Medium India	61463686295
	FF156	5	Fine India	61463686290
152x19	MF166	5	Medium India	61463686310
	FF166	5	Fine India	61463686305
152x25	MF176	5	Medium India	61463686325
203x19	MF180	5	Medium India	61463626130
	FF180	5	Fine India	61463626082

BONDED  
ABRASIVES

SUPER  
ABRASIVES

DIAMOND  
TOOLS

CLEANING,  
POLISHING  
& MASKING

PERSONAL  
PROTECTION  
EQUIPMENT

TECHNICAL  
INFORMATION

## PRECISION FILES

DIM  
(mm)

TYPE

PK  
QTY

GOOD

### KNIFE BLADE FILES

LxWxH



102x25x3	MF724	5	Medium India	61463686775
	FF724	5	Fine India	61463686770

### SILVERSMITH FILES

LxWxH



102x13x2	FF444	5	Fine India	61463686955
	MF444	5	Medium India	61463686960

**Dimensions Key:** DIM = Dimensions, L = Length, W = Width, H = Height

BONDED  
ABRASIVES

SUPER  
ABRASIVES

DIAMOND  
TOOLS

CLEANING,  
POLISHING  
& MASKING

PERSONAL  
PROTECTION  
EQUIPMENT

TECHNICAL  
INFORMATION



# ABRASIVE SLIPS & SPECIALTIES

Norton abrasive slips and specialty stones impart the finest, most uniform finish on a wide range of tools. These fast acting slips hold their shape and are long lasting.

## APPLICATIONS & MARKETS

- Honing
- Gear deburring
- Die cleaning
- Reshaping



BONDED  
ABRASIVES

SUPER  
ABRASIVES

DIAMOND  
TOOLS

CLEANING,  
POLISHING  
& MASKING

PERSONAL  
PROTECTION  
EQUIPMENT

TECHNICAL  
INFORMATION

## CRYSTOLON

GOOD +++



### FEATURES

- Premium silicon carbide abrasive

### BENEFITS

- Fast cutting stone; ideal for general sharpening of cutting tools
- Fast stock removal for quick edge shaping with minimal loading

## INDIA



### FEATURES

- Smooth cutting aluminium oxide abrasive
- Norton's trademark for a fine finish

### BENEFITS

- Ideal when a close tolerance is more important than the speed of cut

## ARKANSAS



### FEATURES

- Natural premium Novaculite quarried in Arkansas & available in soft & hard

### BENEFITS

- Sharpest possible razor edges
- Near mirror finishes
- Use for finer honing after India stone

## PRODUCT SELECTION

APPLICATION	COARSE / MEDIUM SHARPENING	FINE STONING	FINISH HONING
Carbide tools	Medium & Crystolon round edge slip	Fine Crystolon round edge slip	
	Coarse or medium Crystolon carbide tool slip	Fine Crystolon carbide tool slip	
Gouges (wood)		Fine India gouge Sharpening stone	
Leather	Medium Crystolon Tradesmen		
Milling cutter	Medium India round edge slip	Fine India round edge slip	Hard Arkansas round edge slip
Pen knife			Arkansas pen knife
Reamers	Medium India reamer stone	Fine India reamer stone	
Scythe stone	Scythe stone		
Steel tool			Rubber stick

## SLIP STONES

DIM  
(mm)

TYPE

PK  
QTY

GOOD

### CARBIDE TOOL SLIP STONES

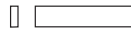

LxWxH

89x19x13	FJT63	5	Fine Crystolon	61463687285
----------	-------	---	----------------	-------------

### ROUND EDGE SLIP STONES

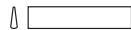

LxWxH

102x25x11	MS14	5	Medium India	61463687140
	FS14	5	Fine India	61463687135
102x32x6	HS14	5	Hard Arkansas	61463687050
114x44x6	MS24	5	Medium India	61463687150
	FJS24	5	Fine Crystolon	61463687075
	FS24	5	Fine India	61463687145
114x44x10	MS34	5	Medium india	61463687165
	FS34	5	Fine India	61463687160
114x44x13	MS44	5	Medium India	61463687180
	FS44	5	Fine India	61463687175

### CARVING TOOL SLIP STONES

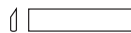

LxWxH

57x22x5	AS22	5	Hard Arkansas ultra-fine	61463687255
---------	------	---	--------------------------	-------------

**Dimensions Key:** DIM = Dimensions, DIA = Diameter, L = Length, W = Width, H = Height

BONDED  
ABRASIVES

SUPER  
ABRASIVES

DIAMOND  
TOOLS

CLEANING,  
POLISHING  
& MASKING

PERSONAL  
PROTECTION  
EQUIPMENT

TECHNICAL  
INFORMATION

## SPECIALTY STONES

DIM (mm)	TYPE	PK QTY	GOOD	
----------	------	--------	------	--

### MACHINE KNIFE STONE

DIAxH



102x38	JB74	5	Coarse Crystolon	61463687570
--------	------	---	------------------	-------------

### REAMER STONES

LxWxH

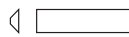

127x25x5	FT125	5	Fine India	61463687430
	MT125	5	Medium India	61463687425

### RUBBING BRICK

LxWxH



203x51x51	BF28	5	Hand Crystolon	61463687845
203x89x38	235	5	Fluted Crystolon	61463687795

### SCYTHE STONE

LxWxH



240x35x13	TJ4	10	Scythe Stone	69936693133
254x32x19	JT930	5	Scythe Stone	61463687675

### RUBBER STICK

LxWxH



200x10x20	-	5	A240FR96	69936625667
-----------	---	---	----------	-------------

**Dimensions Key:** DIM = Dimensions, DIA = Diameter, L = Length, W = Width, H = Height

BONDED  
ABRASIVES

SUPER  
ABRASIVES

DIAMOND  
TOOLS

CLEANING,  
POLISHING  
& MASKING

PERSONAL  
PROTECTION  
EQUIPMENT

TECHNICAL  
INFORMATION

# ORGANIC CUT-OFF WHEELS

Reinforced cut-off wheels contain fiberglass to increase mechanical resistance when in use. The reinforcements increase the lateral stress capacity, resulting in higher resistance to breakage. Non-reinforced cut-off wheels are only designed for use on fixed base machines, where the work is securely clamped, the wheel is adequately guarded and operating on a controlled cutting plane. They are suitable for use in dry or wet conditions, depending on bond type.

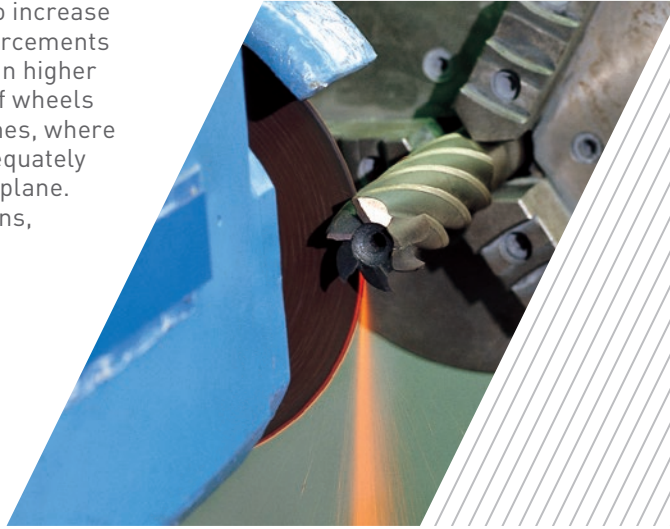

## APPLICATIONS & MARKETS

### REINFORCED CUT-OFF WHEELS

- Foundry – all steel types
- Aerospace
- Automotive

### NON-REINFORCED CUT-OFF WHEELS

- Saw sharpening
- Tool cut-off
- Lab cut-off
- Industrial cut-off

## TOROS 4NZ

BEST +++++



TYPE 41

TYPE 42

### FEATURES

- High concentration of zirconia oxide abrasive
- Extremely tough aluminium oxide abrasive

### BENEFITS

- Very long wheel life
- Very high cutting capability & high metal removal rate if high pressure is applied: shelf re-sharpening
- Perfect for technical applications for premium performances

**TOROS**

## TOROS 5NZ



TYPE 41

TYPE 42

### FEATURES

- Medium concentration of zirconia oxide abrasive
- Extremely tough aluminium oxide abrasive

### BENEFITS

- Long wheel life
- Good metal removal rate
- Versatile: suitable for most steels

BONDED ABRASIVES

SUPER ABRASIVES

DIAMOND TOOLS

CLEANING, POLISHING & MASKING

PERSONAL PROTECTION EQUIPMENT

TECHNICAL INFORMATION

## TOROS XGP



### TYPE 41

#### FEATURES

- Special combination of abrasive blends
- High durability with a good cutting capability

#### BENEFITS

- Very long wheel life & high metal removal rate
- Perfect for lab applications
- Suitable for use on all types of steel

## TOROS 39C



### TYPE 41

#### FEATURES

- Highest purity green silicon carbide abrasive
- Harder & more friable than aluminium oxide abrasive

#### BENEFITS

- Excellent to cut all non metals (titanium, aluminum, bronze)
- Extremely friable abrasive for better cutting efficiency & cut quality



## TOROS U57A

BETTER ++++



TYPE 41

TYPE 42

### FEATURES

- Specially treated brown aluminium oxide abrasive
- Tough & hard aluminium oxide abrasive
- Not suitable for use on extremely hard materials

### BENEFITS

- Long wheel life
- Ideal for heavy duty applications

**TOROS**

## NORZON WITH FOUNDRY X TECHNOLOGY



TYPE 41

TYPE 42

Norzon cut-off wheels with new Foundry X bond technology increase cut rate and wheel life in all cut-off applications on a wide range of tough materials.

### FEATURES

- Foundry X bond technology
- Latest generation of Norzon grain with finer structure and sharper shape
- Excellent micro-fracturing properties

### BENEFITS

- Greater heat resistance
- Longer wheel life
- Lower total abrasive cost
- Improved cut rate (removes material faster)
- Reduced cycle time
- Lower specific cutting energy relative to previous technology

**NorZon**  
FOUNDRY X TECHNOLOGY

BONDED ABRASIVES

SUPER ABRASIVES

DIAMOND TOOLS

CLEANING, POLISHING & MASKING

PERSONAL PROTECTION EQUIPMENT

TECHNICAL INFORMATION

## TOROS 57A

GOOD +++



### TYPE 41

#### FEATURES

- Semi-friable aluminium oxide abrasive
- Less tough than type A abrasive but offers better cutting quality
- Pointed shape

#### BENEFITS

- Cool & burn free cutting
- Ideal for heat-sensitive applications with light to moderate feed rates
- Suitable for all steels
- Good compromise between cut quality & wheel life
- Very versatile: suitable for all steels

**TOROS**

## TOROS 23A



### TYPE 41

#### FEATURES

- An abrasive blend of semi-friable 57A aluminium oxide & white monocristalline 32A aluminium oxide

#### BENEFITS

- Cool & burn free cutting
- Suitable for all steels
- Improved metal removal rate compared to 57A pure semifriable aluminium oxide abrasive

## NORTON WITH FOUNDRY X TECHNOLOGY



### TYPE 41

### TYPE 42

Norton cut-off wheels with new Foundry X bond technology increase cut rate and wheel life in all cut-off applications on a wide range of tough materials.

#### FEATURES

- Foundry X bond technology
- High performance aluminium oxide or silicon carbide grain
- Good choice for low to medium power machines

#### BENEFITS

- Greater heat resistance
- Longer wheel life
- Lower total abrasive cost
- Consistent performance range on standard applications
- Stable surface cut quality





### SPEC CHECK

- B24 New generation bond used on silicon carbide cut-off wheels that gives the best performance & the ultimate cut quality on non-ferrous metals in wet conditions
- B25 Standard multi-purpose bond that offers durability & freeness of cut in a wide variety of materials & applications. Can also be used in wet cutting on softer grades
- B26 New generation bond used on aluminium oxide cut-off wheels that gives the best performance & the ultimate cut quality on ferrous metals in wet conditions
- BF1 Specific bond ensuring the best quality of cut in dry or wet conditions
- BF3 New generation bond assuring the best wheel life in dry cutting operations; versatile & long wheel life. Ideal for heavy duty operations
- B65 Traditional bond gives good performance & long wheel life in dry cutting conditions.
- BFX Engineered Foundry X bond to increase cut rate and wheel life in all your cut-off applications on a wide range of tough materials.

## NON-REINFORCED



DIM DIAxTxB(mm)	MOS (m/s)	PK QTY	BEST	GOOD
--------------------	--------------	-----------	------	------

### TYPE 41

100x1x13	80	25		57A 60 PB25	66253056355
100x1x20	80	25		23A 80 PB25	66253056356
125x1x16	80	25		23A 80 PB25	66253056358
125x1x20	80	25		57A 60 PB25	66253056359
150x1x13	80	25		23A 80 PB25	66253056361
150x1x16	80	25		23A 80 PB25	66253056363
150x1x20	80	25		23A 80 NB25	66253056367
	80	25		23A 80 PB25	66253056368
150x1x32	80	25		57A 60 PB25	66253056373
150x1,6x16	80	25		23A 60 NB25	66253056362
150x1,6x20	63	25		23A 60 LB25	66253056365
	80	25		23A 60 NB25	66253056366
	80	25		57A 60 PB25	66253056364
150x1,6x32	80	25		57A 60 NB25	66253056360
	80	25		57A 60 PB25	66253056372
150x2x20	80	25		23A 60 NB25	66253056370
150x2x32	80	25		57A 60 PB25	66253056369
150x3x32	80	25		57A 60 PB25	66253056374
180x1,6x31,75	80	25		57A 60 PB25	66253056375
	80	25		57A 60 RB25	66253056376
200x1,6x20	80	25		57A 60 PB25	66253056377
200x1,6x32	80	25		57A 60 NB25	66253056382
	80	25		57A 60 PB25	66253056380
200x2x20	63	25		23A 60 LB25	66253056378

**Dimensions Key:** DIM = Dimensions, DIA = Diameter, T = Thickness, B = Bore

BONDED  
ABRASIVES

SUPER  
ABRASIVES

DIAMOND  
TOOLS

CLEANING,  
POLISHING  
& MASKING

PERSONAL  
PROTECTION  
EQUIPMENT

TECHNICAL  
INFORMATION

# NON-REINFORCED



DIM  
DIAxTxB(mm)

MOS  
(m/s)

PK  
QTY

BEST

GOOD

## TYPE 41

250x1,6x25,4	80	10			57A 60 NB25	66253056383
250x1,6x32	63	10	XGP 70 EB26 (Toros)	66253060409		
	63	10	XGP 70 FB26 (Toros)	66253060410		
	63	10	XGP 70 HB26 (Toros)	66253060411		
	63	10	XGP 70 JB26 (Toros)	66253060412		
300x2x32	63	10	XGP 70 EB26 (Toros)	66253060418		
	63	10	XGP 70 FB26 (Toros)	66253060417		
350x2,5x32	63	10	XGP 70 EB26 (Toros)	66253060414		
	63	10	XGP 70 FB26 (Toros)	66253060420		
	63	10	XGP 70 HB26 (Toros)	66253060421		
400x3x32	63	10	XGP 60 FB26 (Toros)	66253060424		
450x3,5x32	63	10	XGP 60 EB26 (Toros)	66253060428		

BONDED  
ABRASIVES

SUPER  
ABRASIVES

DIAMOND  
TOOLS

CLEANING,  
POLISHING  
& MASKING

PERSONAL  
PROTECTION  
EQUIPMENT

TECHNICAL  
INFORMATION

# REINFORCED



DIM  
DIAxTxB  
(mm)

MOS  
(m/s)

PK  
QTY

BEST

BETTER

GOOD

## TYPE 41

150x2x20	80	25			U57A 60 QB25 NA	66253056384		
200x2x32	80	25			U57A 60 OB25 NA	66253056386		
300x3,5x25,4	80	10			NZ30 TBFX	66253385710		
350x3,5x25,4	80	10			NZ30 TBFX	66253385709		
400x4x40	80	10			NZ24 TBFX	66253372431	A24 TBFX	66253372430
400x4,5x40	80	10					57A 24 PB25 NA4	66253059176
500x5x25,4	80	10					57A 24 TB25 NA (RC26)	66253056529
500x5,5x25,4	80	10	4NZ 30 XB25 NA	66253056535	NZ20 TBFX	66253386806	A24 TBFX	66253386805
	80	10					57A 24 PB25 NA4	66253056533
	80	10					57A 24 RB25 NA4 (TBDX METAL)	66253056536
500x5,5x40	80	10			NZ24 TBFX	66253372433	A24 TBFX	66253372432
	100	10			57A2 44 TBF1 NA4 (Toros)	66253056534		
600x6,5x60	100	5			NZ24 TBFX	66253372435	A24 TBFX	66253372434
	100	5					57A 24 PB25 NA6	66253057645

## TYPE 42

400x5x76,2	80	10					A24 TBFX	66253372436
	80	10			NZ24 TBFX	66253372437		
400x5x80	80	10	A24 SBFTOROS DA10	66253362444				
500x6x76,2	80	10			NZ24 TBFX	66253372439	A24 TBFX	66253372438
508x6x76,2	80	10					U57A20 VB25	66253056538

**Dimensions Key:** DIM = Dimensions, DIA = Diameter, T = Thickness, B = Bore



BONDED ABRASIVES

SUPER ABRASIVES

DIAMOND TOOLS

CLEANING, POLISHING & MASKING

PERSONAL PROTECTION EQUIPMENT

TECHNICAL INFORMATION



## REINFORCEMENTS

The main purpose of the fibreglass reinforcement in cut-off wheels is safety. Reinforcements also permit wheels to withstand high rotational speed & make them more flexible. Reinforcements can be external or internal, half or full diameter. Reinforcements impact the cutting profile, affecting both the straightness & quality of cut.

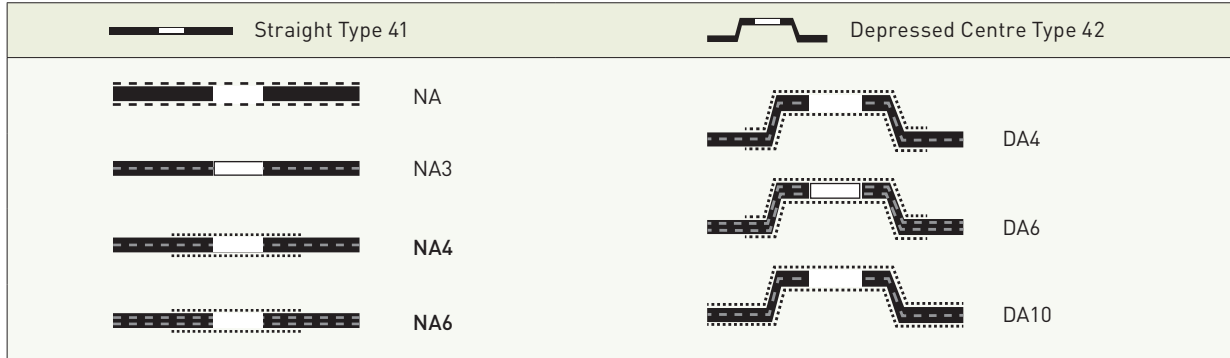

Reduction rings are available upon request to adapt the product to different spindle sizes.

BONDED  
ABRASIVES

SUPER  
ABRASIVES

DIAMOND  
TOOLS

CLEANING,  
POLISHING  
& MASKING

PERSONAL  
PROTECTION  
EQUIPMENT

TECHNICAL  
INFORMATION



### SPEC CHECK

- Non-reinforced cut-off wheels are designed for use on “fixed base” machines where the work is securely clamped, guarded, & where the wheel operates on a controlled cutting plane
- Run the cut-off machine at the highest possible speed marked on the wheel
- Long life wheels should be used on a cut-off machine with 1 horsepower for every 25mm wheel diameter. With a less powerful machine, we recommend starting with a Free Cut specification.

# ORGANIC SNAGGING WHEELS & CUPS

Norton offer a range of products for portable snagging foundry applications. Type 01 straight wheels are used on portable machine and Type 06 and 11 cup wheels on vertical grinders. Since finish tolerances are not usually critical, coarse, durable wheels are used with grit sizes ranging from 16 to 24.

## APPLICATIONS & MARKETS

- Foundries
- Welding shops
- Steel mills
- Forge shops



## ZF7A/ZF7C

**BEST +++++**



### TYPE 01

#### FEATURES

- Special design of abrasive blends
- High durability & versatility

#### BENEFITS

- Very good compromise between wheel life & metal removal rate
- ZF7A is premium product for all steels
- ZF7C is premium product for all non-ferrous metals

## A/AZ

**GOOD +++**



### TYPE 06

### TYPE 11

#### FEATURES

- Tougher than pure white aluminium oxide abrasive
- General purpose abrasive ideal for most operations

#### BENEFITS

- Long wheel life, limited metal removal rate
- AZ is a blend of aluminium oxide & zirconia
- Good for cutting medium to soft steels
- Suitable price/performance position
- First choice for less technical applications

BONDED ABRASIVES

SUPER ABRASIVES

DIAMOND TOOLS

CLEANING, POLISHING & MASKING

PERSONAL PROTECTION EQUIPMENT

TECHNICAL INFORMATION

C



**FEATURES**

- Low purity black silicon carbide abrasive
- Harder & more friable than aluminium type abrasives

**BENEFITS**

- Suitable for roughing operations in coarse grit & resinoid wheels
- Ideal for grinding & sharpening applications on metal carbide & non-ferrous metals
- Standard alternative, first choice if no technical specific requirement

**PORTABLE SNAGGING**

DIM DIAxTxB(mm)	W (mm)	E (mm)	MOS (m/s)	PK QTY	GOOD	
--------------------	-----------	-----------	--------------	-----------	------	--

**TYPE 01**

50x13x10			50	20	A 24 TB	66253057649
100x20x20			50	20	A 24 RB	66253057660
100x25x20			50	20	A 24 PB	66253057663

**TYPE 06**

125x68x20	30	18	50	8	AZ 24 RB	66243450227
-----------	----	----	----	---	----------	-------------

**TYPE 11**

125x50xM14	25	20	50	10	A 20 MB	66243570663
125x50xW5/8	25	20	50	2	C 16 NB	69210432282
150x50xW5/8	40	20	50	4	C 16 NB	69210432287

BONDED ABRASIVES

SUPER ABRASIVES

DIAMOND TOOLS

CLEANING, POLISHING & MASKING

PERSONAL PROTECTION EQUIPMENT

TECHNICAL INFORMATION

## PEDESTAL SNAGGING

DIM  
DIAxTxB(mm)    MOS  
(m/s)    PK  
QTY

BEST

GOOD

### TYPE 01

508x50x50	50	1	ZF7A 16 R5B3	66253057670		
508x60x127	50	1	ZF7A 16 R5B3	66253057671		
760x80x304,8	50	1	ZF7A 14 3RB28	66253057675		

**Dimensions Key:** DIM = Dimensions, DIA = Diameter, T = Thickness, B = Bore, W = Rim Width, E = Back Thickness

## SHAPE KEY

Type 01

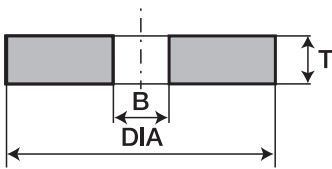

Type 06

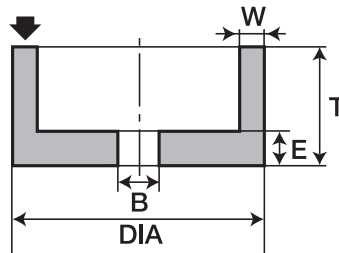

Type 11

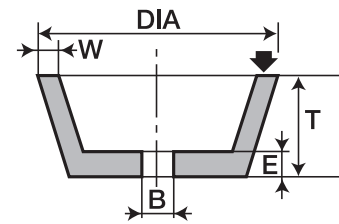

BONDED  
ABRASIVES

SUPER  
ABRASIVES

DIAMOND  
TOOLS

CLEANING,  
POLISHING  
& MASKING

PERSONAL  
PROTECTION  
EQUIPMENT

TECHNICAL  
INFORMATION



### SPEC CHECK

- B & B3 Foundry & portable wheels: multi-purpose bond that gives satisfactory results on most applications
- B28 Foundry wheels: high level bond suitable for most technical applications requiring high powered machines.

# ORGANIC MOUNTED POINTS

NEW Norzon (NZ24) resin bond mounted points are ideal for fast stock removal in tough, aggressive (coarse grit) applications. The Norzon (zirconia alumina) self sharpening abrasive grain and durable organic bond provides 4x faster stock removal than competitive aluminium oxide products with 2x longer life. The best choice for fast aggressive stock removal...

## APPLICATIONS & MARKETS

- Foundries
- Steel mills
- Tool industry

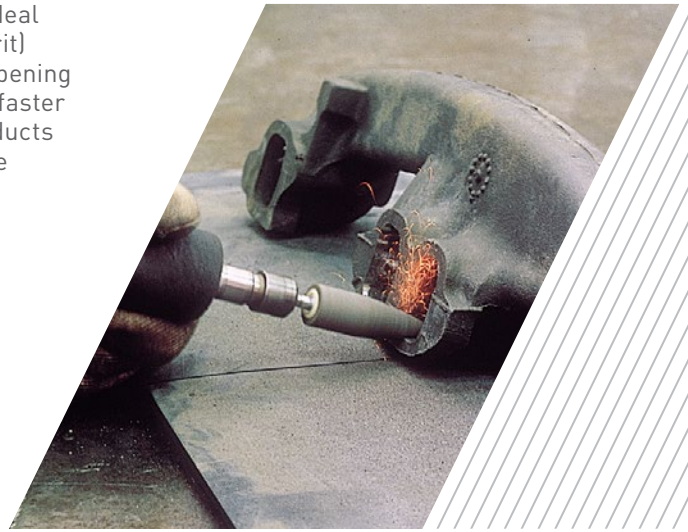

BONDED  
ABRASIVES

SUPER  
ABRASIVES

DIAMOND  
TOOLS

CLEANING,  
POLISHING  
& MASKING

PERSONAL  
PROTECTION  
EQUIPMENT

TECHNICAL  
INFORMATION

## NORZON

BETTER ++++

**NorZon**



### FEATURES

- Zirconia alumina self-sharpening abrasive and durable organic bond

### BENEFITS

- 4x faster stock removal than competitive aluminum oxide products
- Longest lasting

## A

GOOD +++

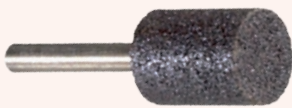

### FEATURES

- Tougher than pure white aluminium oxide abrasive
- General purpose abrasive for most operations

### BENEFITS

- Especially suited for carbon steel, HSS & alloyed steel
- Good for cutting medium hardness – soft steels
- First choice if no technical specific requirement



### SPEC CHECK

- Use "A" shapes for medium- to heavy-duty blending
- Use "W" shapes for offhand and precision grinding of medium to heavy stock.



## ORGANIC MOUNTED WHEELS

SHAPE	DIM DIAxL(mm)	SPINDLE DIAxL(mm)	MOS (RPM)	PK QTY	BETTER		GOOD	
A1	20x65	6x40	15000	10	NZ 24	61463689077		
A3	22x70	6x40	14000	10	NZ 24	61463689079		
A5	20x28	6x40	30000	10	NZ 24	61463689081		
A11	21x45	6x40	18000	10	NZ 24	61463689082		
W177	10x20	6x40	66000	10	NZ 24	61463689084		
W178	10x25	6x40	55200	10	NZ 24	61463689085		
W189	13x50	6x40	30370	10	NZ 24	61463689089		
W188	13x40	6x40	30370	10	NZ 24	61463689090		
	13x40	6x40	30370	20			A 36 QB	66253053225
W204	20x20	6x40	42750	10	NZ 24	61463689091		
W205	20x25	6x40	34500	10	NZ 24	61463689093		
	20x25	6x40	34500	20			A 36 QB	66253053230
W207	20x40	6x40	24000	10	NZ 24	61463689095		
W220	25x25	6x40	25500	10	NZ 24	61463689097		
	25x25	6x40	25500	20			A 46 QB	66253053237
W221	25x40	6x40	19120	10	NZ 24	61463689098		
	25x40	6x40	19120	20			A 46 QB	66253053243
W230	32x32	6x40	24000	10	NZ 24	61463689099		
	32x32	6x40	24000	20			A 36 QB	66253053250
	32x32	6x40	24000	20			A 46 QB	66253053248
W236	40x13	6x40	25130	10	NZ 24	61463689100		
	40x13	6x40	25130	20			A 46 QB	66253053251
W242	50x25	6x40	19100	10	NZ 24	61463689101		
	50x25	6x40	19100	20			A 46 QB	66253053252

**Dimensions Key:** DIM = Dimensions, DIA = Diameter, L = Length

### SHAPE W KEY

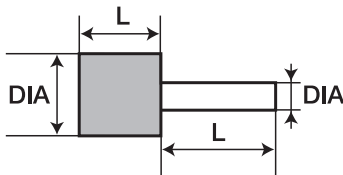

### SHAPE A KEY

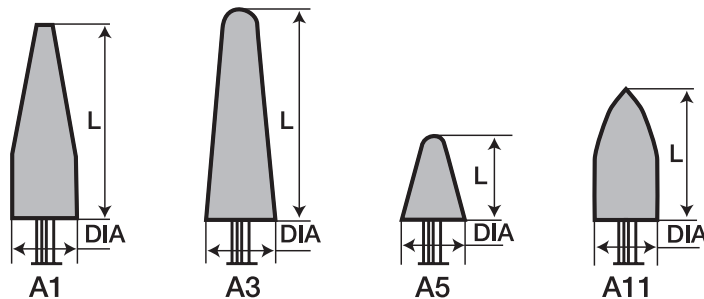

BONDED  
ABRASIVES

SUPER  
ABRASIVES

DIAMOND  
TOOLS

CLEANING,  
POLISHING  
& MASKING

PERSONAL  
PROTECTION  
EQUIPMENT

TECHNICAL  
INFORMATION



# 399-434 SUPER ABRASIVES

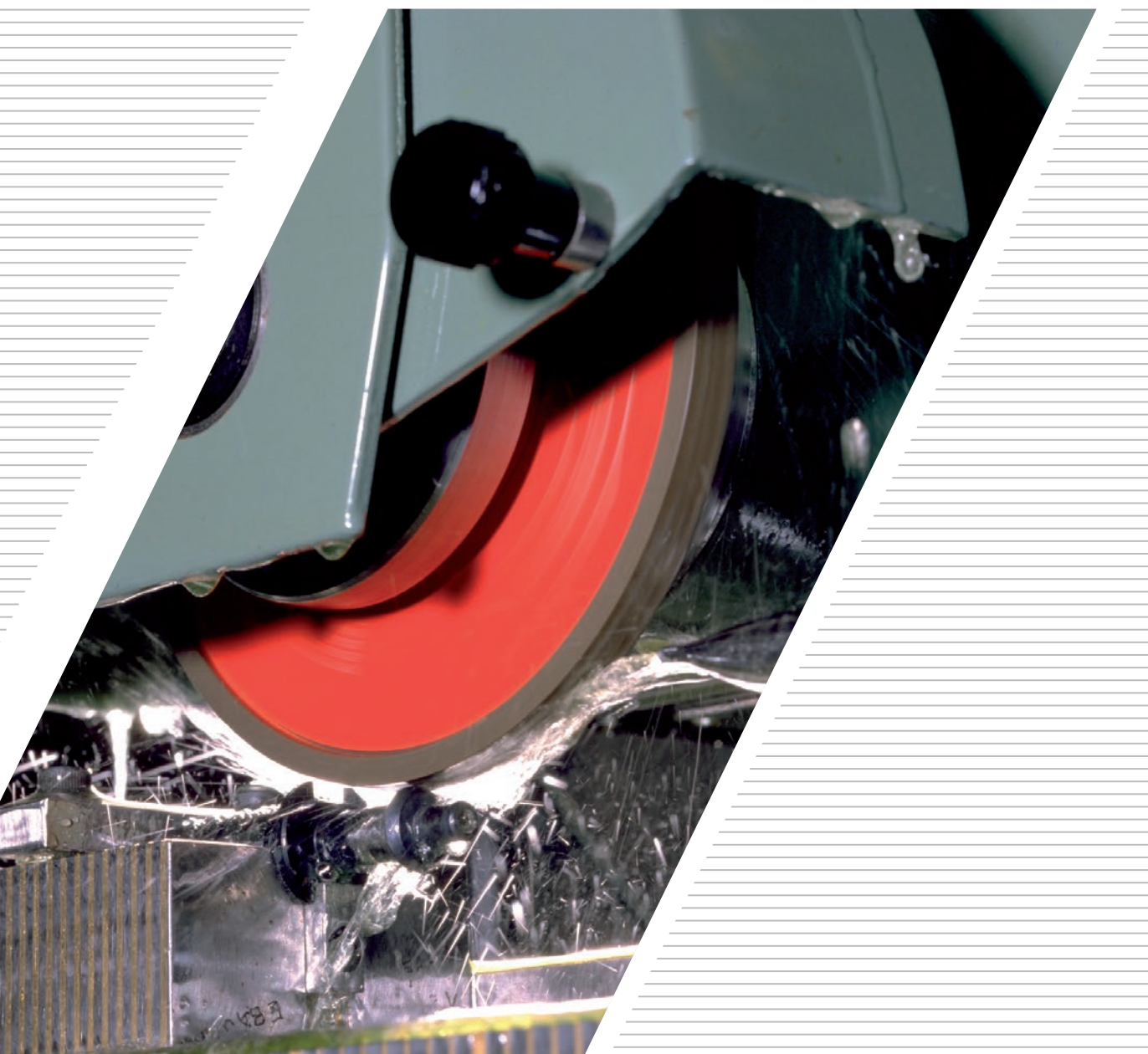

400 Introduction  
402 Diamond & CBN  
Grinding Wheels

425 Diamond Lapping  
Compounds  
426 Diamond Files

427 Diamond Dressers

SUPER  
ABRASIVES

DIAMOND  
TOOLS

CLEANING,  
POLISHING  
& MASKING

PERSONAL  
PROTECTION  
EQUIPMENT

TECHNICAL  
INFORMATION

# INTRODUCTION

Diamond is the hardest material known to man, closely followed by Cubic Boron Nitride (CBN). As a result of their hardness these materials are used extensively in the most demanding precision grinding, slicing, and cutting applications. Super Abrasive wheels use diamond and CBN technology to cut demanding materials such as carbide, high speed steel, ceramics, and glass.

Norton provides ultimate, high performance Super Abrasive solutions for the cutting tools industry, offering products specifically designed to deal with the hardest and most challenging materials.

## UNDERSTANDING THE PRODUCT

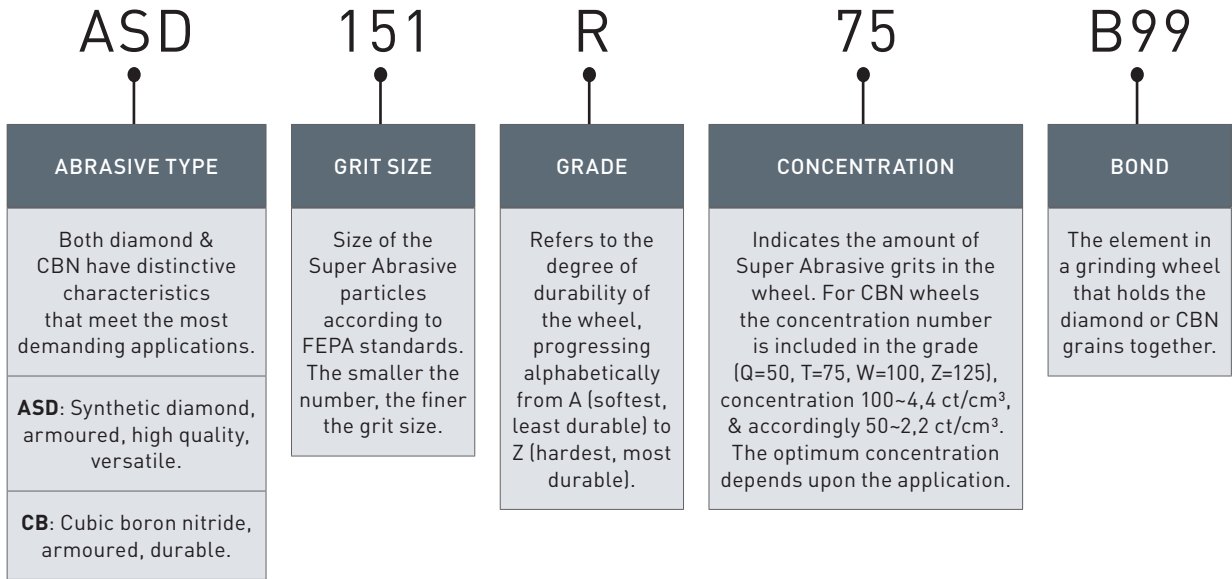

## WHEEL COLOUR

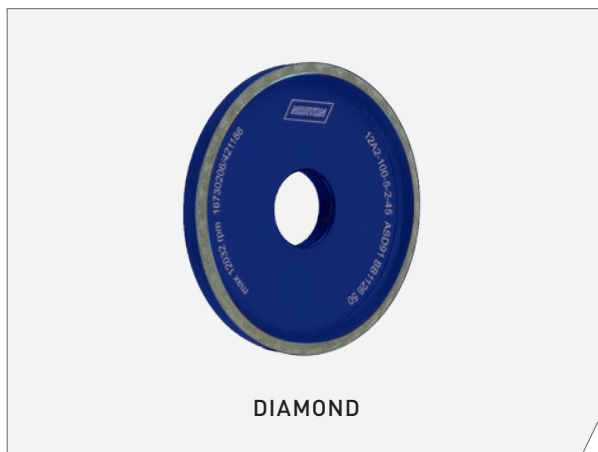

## GRIT SIZE

The grit size selection depends on the required stock removal rate and the required surface finish.

EUROPEAN (FEPA) SIZE	U.S. STANDARD	US NORTON GRIT SIZE [MESH]	
	MESH	DIAMOND	CBN
1182	16/20	16	-
852	20/30	24	24
602	30/40	36	36
501	35/40	-	-
427	40/50	46	46
301	50/60	60	60
251	60/70	-	-
-	50/80	80	80C
252	60/80	100	80
213	70/80	-	-
181	80/100	105	100
-	80/120	100S	120C
151	100/120	110	120
126	120/140	120	150
107	140/170	150	180
91	170/200	180	220
76	200/230	220	230
64	230/270	240	240
54	270/325	320	320
46	325/400	400	400

APPROXIMATE EUROPEAN (FEPA) SIZE	NOMINAL MICRON SIZE	NORTON GRIT SIZE [MESH]
M63	40/60	-
M40	30/40	500
M25	20/30	-
M16	10/20	600
M10	6/12	800
M6,3	4/8	-
M4,0	2/4	-
M1,0	0/2	-

## CONCENTRATION

The concentration influences the stock removal rate and the geometry of the workpiece.

**DIAMOND** 50/75/100/125

**CBN** Q/T/W/Z

## BOND TYPES

**BEST +++++**

**Aztec IV** Premium teflon/silver bond used for dry grinding on in typical tool room applications.

**ECO line** Especially designed resin bonds for saw blade applications.

**BETTER ++++**

**B99** Extremely versatile resin bond used in advanced products both for wet and dry applications.

**GOOD +++**

**B49** Versatile resin bond for dry applications.

## APPLICATIONS & MARKETS

Although both diamond and CBN are Super Abrasives, the areas of usage varies dramatically depending on the workpiece material.

### DIAMOND

- Cemented carbide
- Glass
- Ceramics
- Fibreglass
- Plastics
- Stone
- Abrasives
- Electronic components and materials

### CBN

- High speed tool steels
- Die steels
- Hardened carbon steels
- Alloy steels
- Aerospace alloys
- Hard stainless steel
- Abrasion-resistant ferrous materials



# DIAMOND & CBN GRINDING WHEELS

Norton diamond and CBN wheels are designed to grind and cut the hardest materials known to man, helping make 'difficult-to-grind' applications routine operations. Hardness, abrasion resistance, compressive strength, thermal conductivity are all features designed to achieve a high level of precision and quality, making them a logical choice for a wide range of applications.



## DIAMOND WHEELS



### FEATURES

- High quality synthetic diamond
- Pre-engineered resin bond - B99
- Optimised design

### BENEFITS

- High material removal rates. Longer wheel life versus conventional silicon carbide wheels
- Free cutting; superior form holding. Efficient wet or dry
- Ideal for dry tool room reconditioning applications
- Ideal for 1A1R cut-off applications and grinding glass or ceramic materials
- Fast stock removal, cool cutting; excellent for dry off-hand finishing of carbide tools, no wheel dressing required
- Durable under high grinding forces. Excellent for wet off-hand finishing of carbide tools

## CBN WHEELS

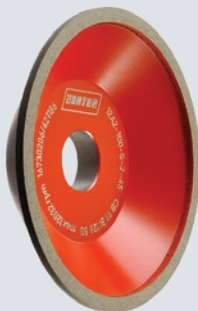

### FEATURES

- High quality durable CBN abrasive
- Pre-engineered resin bond - B99
- High performance Aztec IV bond
- Optimised design

### BENEFITS

- Easily cuts difficult to grind steel parts, HRC 50 or harder
- Highly wear resistant and thermally stable
- Free cutting, superior form holding
- Larger cutting depth
- Extremely efficient for dry tool re-sharpening especially when heavy stock removal is required

SUPER  
ABRASIVES

DIAMOND  
TOOLS

CLEANING,  
POLISHING  
& MASKING

PERSONAL  
PROTECTION  
EQUIPMENT

TECHNICAL  
INFORMATION

# WHEEL SHAPES

1A1  Pages 405, 408, 417, 418

1A1R  Page 420

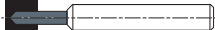
1A1W  Pages 414, 419

1V1  Pages 405, 406

4A2  Pages 412, 422

4A9  Page 414

6A2  Pages 408, 421

6VV5  Page 413

9A3  Page 409

11A2-70°  Page 409

11V2  Page 409

11V9  Pages 407, 410

12A2-20°  Page 423

12A2-45°  Page 424

12V2  Page 412

12V9  Pages 406, 410, 412

13A2  Page 423

14F1  Pages 415, 421

14M1  Page 413

SUPER ABRASIVES

DIAMOND TOOLS

CLEANING, POLISHING & MASKING

PERSONAL PROTECTION EQUIPMENT

TECHNICAL INFORMATION

# ROUND TOOLS

## DIAMOND AND CBN GRINDING WHEELS

### FOR THE MACHINING OF ROUND TOOLS

Norton offers a comprehensive, newly designed product range for work on round tools such as drills, end mills and reamers. Diamond and CBN grinding wheels are ideal for producing and re-sharpening tungsten carbide and HSS tools.

The following sections are arranged by application for easy identification of the correct grinding wheel for fluting, gashing, grinding of clearance angles and re-sharpening. Within the sub-chapters the grinding wheels are ordered by FEPA code.



### BOND OVERVIEW DIAMOND

BOND	WEAR RESISTANCE	RECOMMENDATION FOR USE
R100 B99	↑	For CNC grinding operations (wet)
R75 B99		For universal grinding (wet or dry)
R50 B99		For universal grinding (wet or dry)

### BOND OVERVIEW CBN

BOND	WEAR RESISTANCE	RECOMMENDATION FOR USE
W B99	↑	For CNC grinding operations (wet)
T B99		For universal grinding (wet or dry)
Aztec IV		Very free grinding dry grinding bond

# ROUND TOOLS CNC GRINDING

The Norton B99 resin bonded wheel is ideal for flute grinding on CNC machines and is particularly suitable for applications on standard tools.

D64R100B99 and B107 W B99 are the most commonly used products for flute grinding, however other specifications can be made available on request.

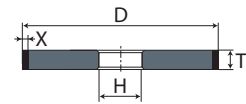
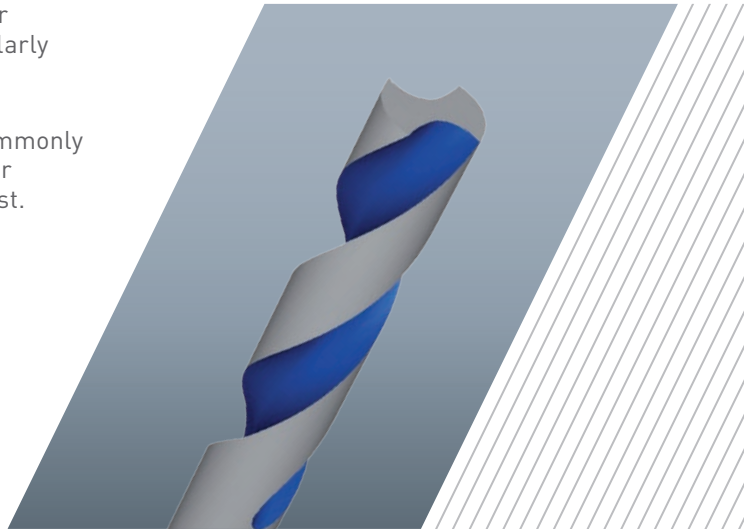

## 1A1 FLUTING

D (mm)	T (mm)	X (mm)	H (mm)	PK QTY	SPECIFICATION	ART. NO.
<b>DIAMOND</b>						
100	6	3	32	1	ASD91 R100 B99	7958732719
	10	5	20	1	ASD64 R100 B99	7958732706
	12	5	20	1	ASD64 R100 B99	7958732713
	15	5	20	1	ASD64 R100 B99	7958732714
125	5	3	20	1	ASD126 R100 B99	7958732469
	10	10	20	1	ASD64 R100 B99	7958732470
	12	10	20	1	ASD64 R100 B99	7958732471
150	12	10	20	1	ASD64 R100 B99	7958732727
<b>CBN</b>						
100	10	5	20	1	CB107 W B99	7958732712
125	10	10	20	1	CB107 W B99	7958728828
100	15	5	20	1	CB107 W B99	7958732716

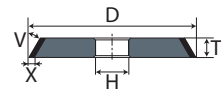

## 1V1 FLUTING

D (mm)	T (mm)	X (mm)	V (mm)	H (mm)	PK QTY	SPECIFICATION	ART. NO.
<b>DIAMOND</b>							
100	10	5	10	20	1	ASD64 R100 B99	7958732976
	15	5	20	20	1	ASD64 R100 B99	7958732974
125	10	5	30	20	1	ASD64 R100 B99	7958732984
<b>CBN</b>							
100	15	5	20	20	1	CB107 W B99	7958732994

SUPER ABRASIVES

DIAMOND TOOLS

CLEANING, POLISHING & MASKING

PERSONAL PROTECTION EQUIPMENT

TECHNICAL INFORMATION

The state-of-the-art Norton B99 resin bond is free cutting and has good corner stability, the most essential characteristic required for CNC gashing.

Two standard specifications are offered:

- for tungsten carbide tools: ASD64 R100 B99
- for HSS-tools: CB107 W B99.

Both are available in 12V9 as well as in 1V1 shape.

Further combinations of dimensions, grit sizes and concentrations are available on request.

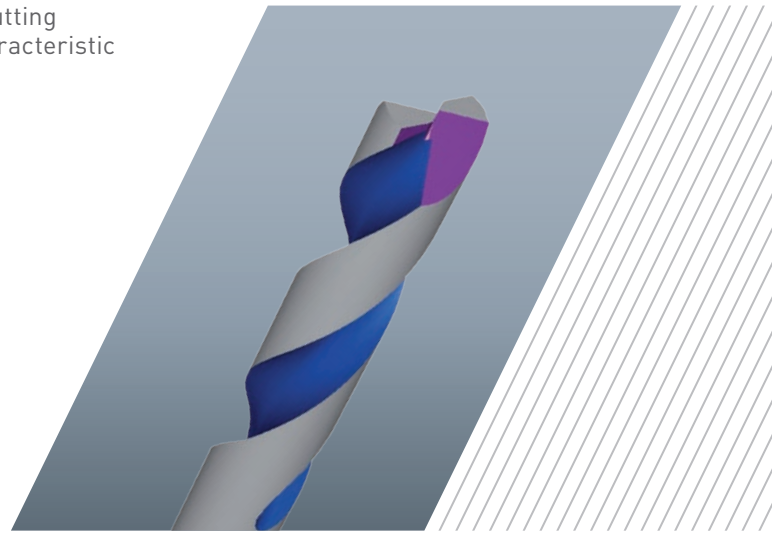

### 1V1 GASHING

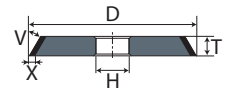

D (mm)	T (mm)	X (mm)	V (mm)	H (mm)	PK QTY	SPECIFICATION	ART. NO.	ADDITIONAL INFORMATION
<b>DIAMOND</b>								
100	15	5	45	20	1	ASD64 R100 B99	7958732996	
125	15	5	45	20	1	ASD64 R100 B99	7958733015	
<b>CBN</b>								
100	15	5	45	20	1	CB107 W B99	7958733013	
125	12	5	45	20	1	CB107 W B99	7958733017	

### 12V9 GASHING

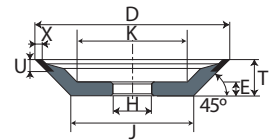

D (mm)	X (mm)	U (mm)	H (mm)	T (mm)	K (mm)	E (mm)	J (mm)	PK QTY	SPECIFICATION	ART. NO.	ADDITIONAL INFORMATION
<b>DIAMOND</b>											
100	2	10	20	20	52	11	60	1	ASD64 R100 B99	7958732837	Stiffened body
	3	10	20	20	52	11	60	1	ASD64 R100 B99	7958732832	Stiffened body
125	2	10	20	25	60	12	74	1	ASD64 R100 B99	7958733019	Stiffened body
150	3	10	20	25	81	15	99	1	ASD64 R100 B99	7958732919	Stiffened body
<b>CBN</b>											
100	3	10	20	20	52	11	60	1	CB107 W B99	7958732826	Stiffened body
125	3	10	20	25	71	14	74	1	CB107 W B99	7958732814	Stiffened body
150	3	10	20	25	81	15	99	1	CB107 W B99	7958732920	Stiffened body



Norton B99 resin bond tools are an ideal choice for grinding clearances and relief angles on CNC machines. With excellent cutting behaviour the bond produces a good surface finish. The listed grinding wheels are suitable for the production and re-sharpening of tungsten carbide and HSS round tools.

D64 R100 and B107 W are the most common specifications for clearance angle grinding applications, however, other specifications are available on request.

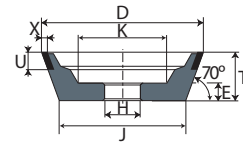
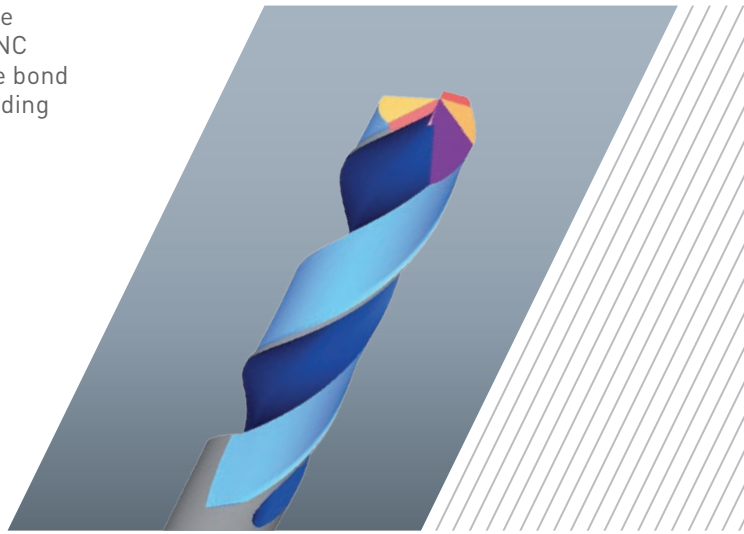

### 11V9 CLEARANCE ANGLE GRINDING

D (mm)	X (mm)	U (mm)	H (mm)	T (mm)	K (mm)	E (mm)	J (mm)	PK QTY	SPECIFICATION	ART. NO.	ADDITIONAL INFORMATION
<b>DIAMOND</b>											
75	2	10	20	30	40	10	53	1	ASD64 R100 B99	7958732849	Stiffened body
100	2	10	20	35	59	15	74	1	ASD64 R100 B99	7958732876	Stiffened body
	3	10	20	35	53	15	74	1	ASD64 R100 B99	7958732877	Stiffened body
125	3	10	20	40	70	18	95	1	ASD64 R100 B99	7958732856	Stiffened body
<b>CBN</b>											
75	2	10	20	30	40	10	53	1	CB107 W B99	7958732851	Stiffened body
100	2	10	20	35	59	15	74	1	CB107 W B99	7958732874	Stiffened body
	3	10	20	35	53	15	74	1	CB107 W B99	7958732844	Stiffened body
125	3	10	20	40	70	18	95	1	CB107 W B99	7958732854	Stiffened body

SUPER ABRASIVES

DIAMOND TOOLS

CLEANING, POLISHING & MASKING

PERSONAL PROTECTION EQUIPMENT

TECHNICAL INFORMATION

# ROUND TOOLS UNIVERSAL GRINDING

Norton offers a comprehensive selection of different bonds and concentrations for re-sharpening applications on universal machines. The B99 grinding wheels can be used wet or dry.

The lower the diamond or CBN concentration the more suited the product will be to grinding large contact areas. Aztec IV is a special free cutting resin bond which is designed for dry grinding operations and enables high material removal.

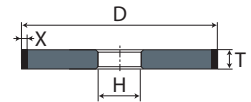
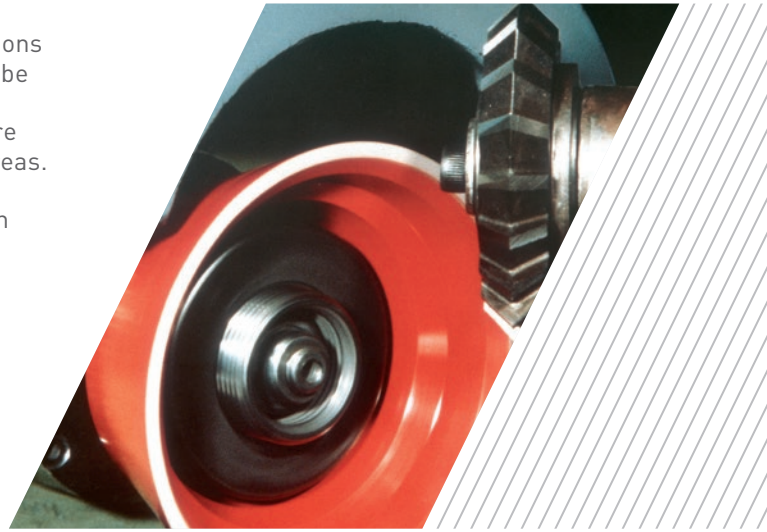

## 1A1 RE-SHARPENING

D (mm)	T (mm)	X (mm)	H (mm)	PK QTY	SPECIFICATION	ART. NO.
<b>DIAMOND</b>						
100	4	3	20	1	ASD91 R75 B99	7958732717
	10	5	20	1	ASD91 R75 B99	7958732711
125	10	5	20	1	ASD126 R100 B99	7958732466
150	10	3	20	1	ASD126 R50 B99	7958732724
	10	3	32	1	ASD126 R75 B99	7958732726
<b>CBN</b>						
100	10	3	20	1	CB126 T B99	7958732704
150	10	3	20	1	CB126 T B99	7958732725

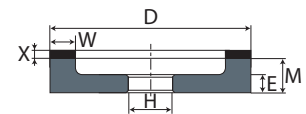

## 6A2 RE-SHARPENING

D (mm)	W (mm)	X (mm)	H (mm)	M (mm)	E (mm)	PK QTY	SPECIFICATION	ART. NO.
<b>DIAMOND</b>								
100	6	4	20	23	10	1	ASD151 R75 B99	7958732881
	12	2	20	18	10	1	ASD54 R50 B99	7958732886
	12	2	20	18	10	1	ASD107 R50 B99	7958732879
125	6	5	20	25	10	1	ASD64 R75 B99	7958732922
	10	2	70	23	10	1	ASD107 R50 B99	7958732882
150	10	2	20	23	10	1	ASD91 R50 B99	7958732932
	15	2	32	23	10	1	ASD107 R50 B99	7958732933
	20	2	20	20	10	1	ASD126 R75 B99	7958732934
<b>CBN</b>								
125	6	4	20	23	10	1	CB151 T B99	7958732925
150	6	4	20	23	10	1	CB151 T B99	7958732936
	6	4	32	23	10	1	CB151 T B99	7958732935

SUPER ABRASIVES

DIAMOND TOOLS

CLEANING, POLISHING & MASKING

PERSONAL PROTECTION EQUIPMENT

TECHNICAL INFORMATION

**9A3 RE-SHARPENING**

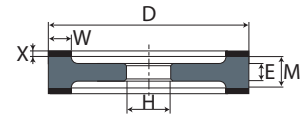

D (mm)	W (mm)	X (mm)	H (mm)	M (mm)	E (mm)	PK QTY	SPECIFICATION	ART. NO.
<b>DIAMOND</b>								
175	5	2	20	30	14	1	ASD64 R50 B99	7958733005
	5	2	20	30	14	1	ASD126 R50 B99	7958733002
	5	2	20	30	14	1	ASD46 R50 B49	66260120338
	5	2	20	30	14	1	ASD64 R50 B49	66260120339
	5	2	20	30	14	1	ASD126 R50 B49	66260120340

**11A2-70° RE-SHARPENING**

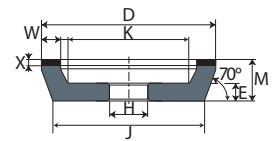

D (mm)	W (mm)	X (mm)	H (mm)	M (mm)	K (mm)	E (mm)	J (mm)	PK QTY	SPECIFICATION	ART. NO.
<b>DIAMOND</b>										
100	5	4	20	20	75	10	88	1	ASD151 R75 B99	60157682163
<b>CBN</b>										
100	5	4	20	20	75	10	88	1	CB126 T B99	60157682165

**11V2 RE-SHARPENING**

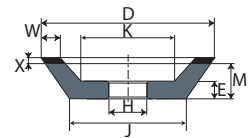

D (mm)	W (mm)	X (mm)	H (mm)	M (mm)	K (mm)	E (mm)	J (mm)	PK QTY	SPECIFICATION	ART. NO.
<b>DIAMOND</b>										
100	5	3	20	20	72	8	82	1	ASD91 R75 B99	7958733007
	5	3	20	20	72	8	82	1	ASD126 R75 B99	7958733011

SUPER  
ABRASIVES

DIAMOND  
TOOLS

CLEANING,  
POLISHING  
& MASKING

PERSONAL  
PROTECTION  
EQUIPMENT

TECHNICAL  
INFORMATION

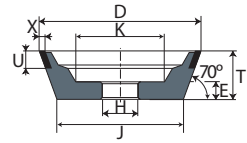

### 11V9 RE-SHARPENING

D (mm)	X (mm)	U (mm)	H (mm)	T (mm)	K (mm)	E (mm)	J (mm)	PK QTY	SPECIFICATION	ART. NO.
<b>DIAMOND</b>										
75	2	10	20	30	40	10	53	1	ASD107 R75 B99	7958732857
	2	10	20	30	40	10	53	1	ASD126 R75 B99	7958732859
	2	10	20	30	40	10	53	1	SD64 R75 B49	66260120321
	2	10	20	30	40	10	53	1	SD126 R75 B49	66260120322
100	2	10	20	35	55	10	74	1	ASD126 R75 B99	7958732867
	3	10	20	35	60	10	74	1	ASD126 R75 B99	7958732862
	3	10	32	35	60	10	74	1	ASD126 R75 B99	7958732865
	2	10	20	35	55	10	75	1	SD64 R75 B49	66260120323
	2	10	20	35	55	10	75	1	SD126 R75 B49	7958795053
125	3	10	20	40	81	10	96	1	ASD126 R75 B99	7958732847
	3	10	32	40	81	10	96	1	ASD126 R75 B99	7958732848
<b>CBN</b>										
75	1,5	10	20	30	40	10	53	1	BN181 Aztec IV	69014152323
	2	10	20	30	40	10	53	1	CB126 T B99	7958732853
	2	10	20	30	40	10	53	1	CB126 R75 B49	66260121233
100	1,5	10	20	35	55	10	75	1	BN126 Aztec IV	69014152115
	1,5	10	20	35	55	10	75	1	BN181 Aztec IV	69014152118
	1,5	10	32	35	55	10	75	1	BN181 Aztec IV	69014152120
	2	10	20	35	55	10	74	1	CB126 T B99	7958732869
	2	10	32	35	55	10	74	1	CB126 T B99	7958732871
	2	10	20	35	55	10	75	1	CB126 R75 B49	66260121234

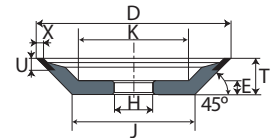

### 12V9 RE-SHARPENING

D (mm)	X (mm)	U (mm)	H (mm)	T (mm)	K (mm)	E (mm)	J (mm)	PK QTY	SPECIFICATION	ART. NO.
<b>DIAMOND</b>										
75	2	10	20	25	34	10	39	1	ASD64 R75 B99	7958732816
	2	6	20	20	45	10	42	1	ASD126 R75 B99	7958732811
	3	6	20	20	45	10	42	1	ASD76 R75 B99	7958732890
	2	10	20	20	45	10	35	1	SD15 R50 B49	66260120324
	2	10	20	20	45	10	35	1	SD64 R75 B49	66260120326
	2	10	20	20	45	10	35	1	SD126 R75 B49	66260120327
100	2	6	20	20	64	10	59	1	ASD126 R75 B99	7958732821
	3	10	20	20	65	10	59	1	ASD46 R75 B99	7958732885
	2	10	20	20	65	10	60	1	SD15 R50 B49	66260120328
	2	10	20	20	65	10	60	1	SD64 R75 B49	66260120329
	2	10	20	20	65	10	60	1	SD126 R75 B49	66260120330
<b>CBN</b>										
75	2	6	20	20	45	10	42	1	CB107 T B99	7958732813
	2	10	20	20	45	10	35	1	CB126 R75 B49	66260121235
100	2	6	20	20	65	10	59	1	CB126 T B99	7958732818
	3	10	20	20	65	10	59	1	CB126 T B99	7958732880
	2	10	20	20	65	10	60	1	CB126 R75 B49	66260121236

# SAW BLADES

## DIAMOND AND CBN GRINDING WHEELS

### FOR THE SAW BLADE INDUSTRY

Norton provides a comprehensive range of diamond and CBN grinding wheels. With an emphasis on excellent price vs. performance ratios, the saw blade programme aims to provide the best solutions for grinding tungsten carbide tipped saw blades and one-piece HSS saws.

The tungsten carbide tipped circular saw blade grinding wheels have been specifically designed for face grinding and flank grinding. Norton offers grinding wheels for the most common machine types required for these applications.

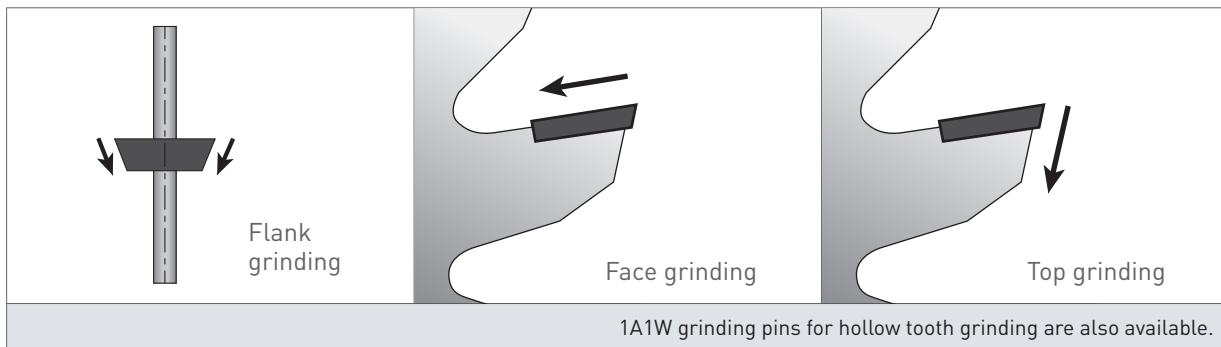

### BOND OVERVIEW DIAMOND

BOND	WEAR RESISTANCE	RECOMMENDATION FOR USE
<b>ECO</b> Face	↑	Face grinding of tungsten carbide tipped saw blades
<b>ECO</b> Flank		Flank grinding of tungsten carbide tipped saw blades
<b>ECO</b> Top-AW		Top-grinding of tungsten carbide tipped saw blades on AKEMAT and WOODTRONIC machines
<b>ECO</b> Top		Universal top-grinding of tungsten carbide tipped saw blades
<b>ECO</b> Top-R		Top-grinding of tungsten carbide tipped saw blades, especially re-sharpening
<b>ECO</b> Top-P		Top-grinding of tungsten carbide tipped saw blades, especially production
<b>B99</b>		Universal resin bond for wet and dry grinding

### BOND OVERVIEW CBN

BOND	WEAR RESISTANCE	RECOMMENDATION FOR USE
<b>ECO</b> Curve		Profiling and re-sharpening of HSS saw blades

SUPER ABRASIVES

DIAMOND TOOLS

CLEANING, POLISHING & MASKING

PERSONAL PROTECTION EQUIPMENT

TECHNICAL INFORMATION



# SAW BLADES TUNGSTEN CARBIDE TIPPED SAWS

The tooth face of circular saw blades is ground with sharp angled cup wheels. Depending on the tooth pitch, different angles and wheel thicknesses are required. The greater the number of teeth around the circumference, the narrower the space between them and the thinner the grinding wheel needs to be. Even the narrowest tooth gaps can be machined with our 12V9 **ECO** Face wheels.

For reasons of stability, conventional tooth gaps are mainly ground using 4A2 or 12V2 grinding wheels.

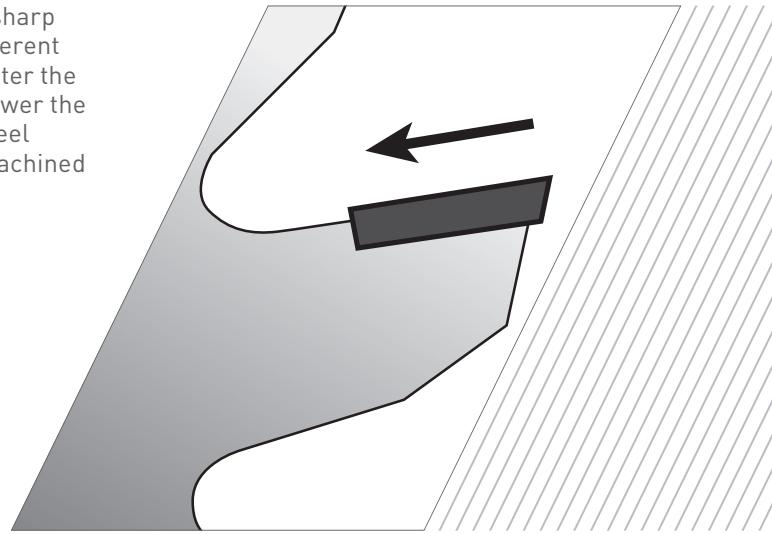

## 4A2 FACE GRINDING

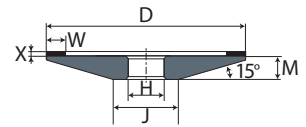

D (mm)	W (mm)	X (mm)	H (mm)	M (mm)	J (mm)	PK QTY	SPECIFICATION	ART. NO.	ADDITIONAL INFORMATION
<b>DIAMOND</b>									
100	5	2	25*	7	51,5	1	ASD91 R75 B99	7958725784	For conventional tooth gaps

\*4A2K (with Keyway)

## 12V2 FACE GRINDING

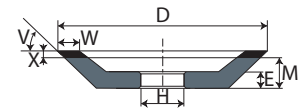

D (mm)	W (mm)	X (mm)	H (mm)	M (mm)	V (mm)	E (mm)	PK QTY	SPECIFICATION	ART. NO.	ADDITIONAL INFORMATION
<b>DIAMOND</b>										
125	4	2	32	11	30	9	1	ASD46 R125 B99	60157682189	For conventional tooth gaps
	4	2	32	11	30	9	1	ASD76 R125 B99	60157682188	For conventional tooth gaps
200	4	2	32	13	30	11	1	ASD46 R125 B99	7958725781	For conventional tooth gaps
	4	2	32	13	30	11	1	ASD76 R125 B99	7958725780	For conventional tooth gaps

## 12V9 FACE GRINDING

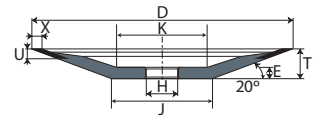

D (mm)	X (mm)	U (mm)	H (mm)	T (mm)	K (mm)	E (mm)	J (mm)	PK QTY	SPECIFICATION	ART. NO.	ADDITIONAL INFORMATION
<b>DIAMOND</b>											
100	2,3	4	25*	10	77	7	51	1	D46 <b>ECO</b> Face	7958717431	For narrow tooth gaps
125	2,3	4	25*	10	101	7	76	1	D46 <b>ECO</b> Face	7958714565	For narrow tooth gaps
	2,3	4	32	13	101	10	70	1	D46 <b>ECO</b> Face	69014148184	For narrow tooth gaps
150	2,3	4	32	13	126	10	95	1	D46 <b>ECO</b> Face	7958719191	For narrow tooth gaps
200	2,3	4	32	13	173	10	145	1	D46 <b>ECO</b> Face	69014148205	For narrow tooth gaps

\*12V9K (with keyway)

SUPER ABRASIVES

DIAMOND TOOLS

CLEANING, POLISHING & MASKING

PERSONAL PROTECTION EQUIPMENT

TECHNICAL INFORMATION

To ensure the circular nature of the saw and to define the wedge and clearance angles, the top of the saw blade needs to be ground.

Vollmer and Widma machines normally require 6VV5 cup wheels Akemat and Woodtronic machines require 14M1 state of the art peripheral wheels.

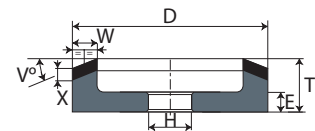
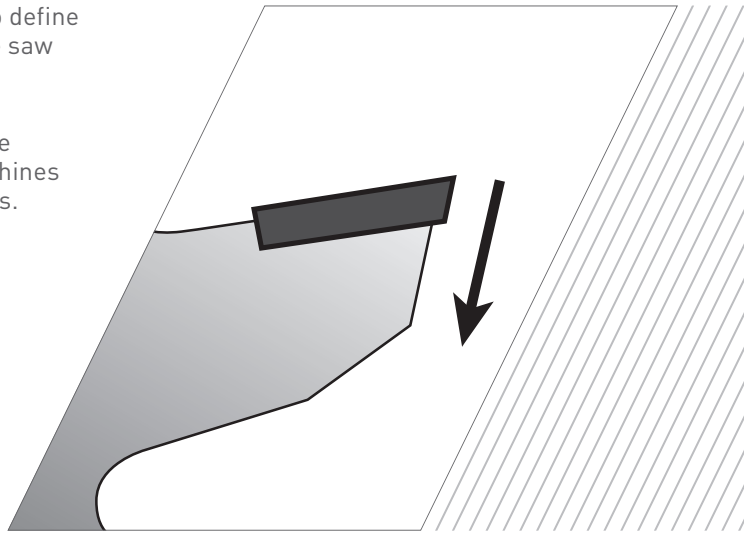

### 6VV5 TOP GRINDING

D (mm)	W (mm)	X (mm)	V (mm)	H (mm)	T (mm)	E (mm)	PK QTY	SPECIFICATION	ART. NO.	ADDITIONAL INFORMATION
DIAMOND										
100	5	10	8	25*	24	7	1	ASD126/46 R100/R75 <b>ECO</b> TOP	7958725658	Universal use
125	5	10	8	32	22	11	1	ASD126/46 R100/R75 <b>ECO</b> TOP	7958725660	Universal use
	5	10	8	32	22	11	1	ASD126/46 R100/R75 <b>ECO</b> TOP-P	7958725661	For production, oil
	5	10	8	32	22	11	1	ASD126/46 R125/R100 <b>ECO</b> TOP-R	7958725663	For re-sharpening

\*6VV5K (with keyway)

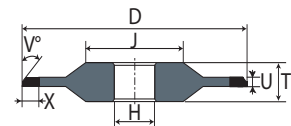

### 14M1 TOP GRINDING

D (mm)	U (mm)	X (mm)	V (mm)	H (mm)	T (mm)	J (mm)	PK QTY	SPECIFICATION	ART. NO.	ADDITIONAL INFORMATION
DIAMOND										
150	5	8	8	32	10	119	1	ASD107/46 R100/R75 <b>ECO</b> TOP-AW	7958725785	D126/D46: U=2,5/2,5
200	5	8	8	32	10	156	1	ASD126/46 R100/R75 <b>ECO</b> TOP-AW	7958725786	D126/D46: U=2,5/2,5

#### COLOUR CODES FOR MACHINE MANUFACTURERS



SUPER ABRASIVES

DIAMOND TOOLS

CLEANING, POLISHING & MASKING

PERSONAL PROTECTION EQUIPMENT

TECHNICAL INFORMATION

During the flank grinding process the cutting width of the circular saw blade is defined. Therefore, typically two 4A9 grinding wheels are simultaneously fed from both sides.

When manufacturing saw blades there is a wide variety of tooth geometries and designs to choose from. Depending on the intended use of the saw, the tooth design can be flat, alternate, trapezoid or any combination of these. Hollow ground teeth are very common to achieve finer cuts with no burrs. The rounded shape of hollow ground teeth is produced with 1A1W grinding pins.

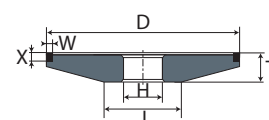
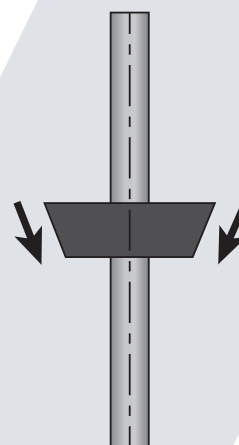

### 4A9 FLANK GRINDING

D (mm)	X (mm)	W (mm)	H (mm)	T (mm)	J (mm)	PK QTY	SPECIFICATION	ART. NO.	ADDITIONAL INFORMATION
DIAMOND									
80	4	5	32	10	53	1	ASD64 <i>ECO</i> Flank	7958725778	Universal use
86	4	5	32	10	59	1	ASD64 <i>ECO</i> Flank	7958725779	Universal use
100	4	4,5	20*	14	35	1	ASD64 <i>ECO</i> Flank	7958725739	Universal use
	4	4,5	20*	14	35	1	ASD126 <i>ECO</i> Flank	7958725744	Universal use
	4	5	32	10	55	1	ASD64 <i>ECO</i> Flank	7958725737	Universal use
	4	5	32	10	55	1	ASD126 <i>ECO</i> Flank	7958725738	Universal use

\*4A9K (with Keyway)

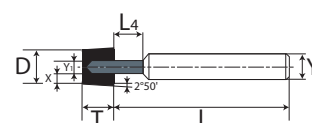

### 1A1W HOLLOW TOOTH GRINDING

D (mm)	T (mm)	X (mm)	Y (mm)	L (mm)	Y <sub>1</sub> (mm)	L <sub>4</sub> (mm)	PK QTY	SPECIFICATION	ART. NO.	ADDITIONAL INFORMATION
DIAMOND										
6,5	3	1,75	6	42	4,1	10	1	ASD76 R125 B99	7958725782	For all common machines
7	3	2	6	42	5,1	10	1	ASD76 R125 B99	7958725783	For all common machines

### COLOUR CODES FOR MACHINE MANUFACTURERS

Vollmer-Biberach

Vollmer-Dornhan

Woodtronic

Akemat

Widma

## SAW BLADES HSS SAWS

HSS saw blades are one-piece saws that are ground from one solid piece of metal. For this process HSS saws require special grinding machines.

14F1 wheels grind the required profile under CNC control. Wheels are ideal for both initial profiling and re-sharpening thanks to the advanced resin bond systems which ensure the wheels are economic and extremely wear resistant.

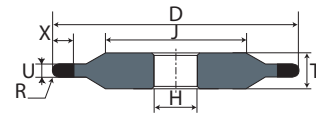
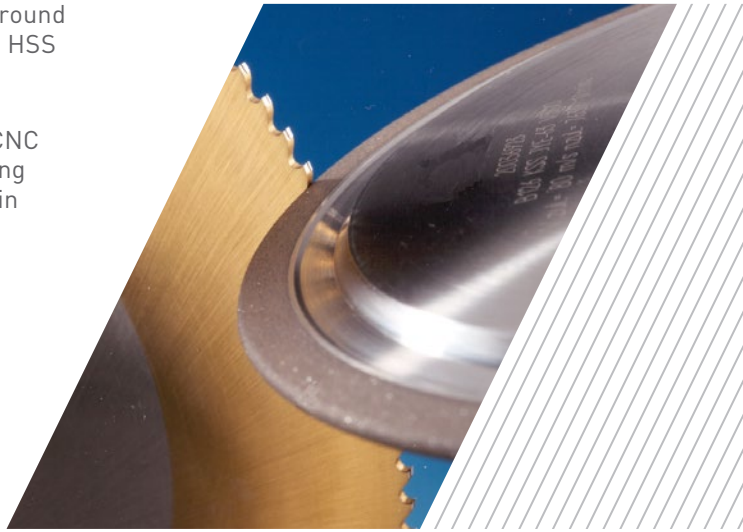

### 14F1 INITIAL PROFILING AND RE-SHARPENING

D (mm)	U (mm)	X (mm)	R (mm)	H (mm)	T (mm)	J (mm)	PK QTY	SPECIFICATION	ART. NO.	ADDITIONAL INFORMATION
CBN										
200	1,3	6,5	0,65	32	8	169	1	CB107 <b>ECO</b> Curve	7958706686	For Loroch machines
	1,6	7	0,8	32	8	164	1	CB107 <b>ECO</b> Curve	7958714307	For Loroch machines
	2	8	1	32	8	164	1	CB107 <b>ECO</b> Curve	7958706684	For Loroch machines
	2,5	8	1,25	32	8	159	1	CB107 <b>ECO</b> Curve	7958716444	For Loroch machines
	3	10	1,5	32	8	160	1	CB107 <b>ECO</b> Curve	7958718179	For Loroch machines
	4	12,5	2	32	8	157	1	CB107 <b>ECO</b> Curve	7958716216	For Loroch machines



SUPER ABRASIVES

DIAMOND TOOLS

CLEANING, POLISHING & MASKING

PERSONAL PROTECTION EQUIPMENT

TECHNICAL INFORMATION

# GENERAL ENGINEERING

## DIAMOND AND CBN GRINDING WHEELS

### FOR GENERAL ENGINEERING

Norton diamond and CBN wheels for general engineering are suitable for many grinding applications like OD-, ID-, and flat grinding, machining of knives, milling cutters and polishing.

Most of the bonds listed in this section are made with ASD (armoured synthetic diamonds) grit and are suitable for wet and dry grinding applications. Some wheels use AMD (armoured metal bond diamonds) which are more wear resistant but require a coolant.

More information about the application can be found in the relevant sub-chapters.

### BOND OVERVIEW DIAMOND

BOND	WEAR RESISTANCE	RECOMMENDATION FOR USE
R100 B99	↑	For universal grinding (wet or dry)
R75 B99		For universal grinding (wet or dry)
R50 B99		For universal grinding (wet or dry)

### BOND OVERVIEW CBN

BOND	WEAR RESISTANCE	RECOMMENDATION FOR USE
W B99	↑	For universal grinding (wet or dry)
T B99		For universal grinding (wet or dry)
Q B99		For universal grinding (wet or dry)

SUPER  
ABRASIVES

DIAMOND  
TOOLS

CLEANING,  
POLISHING  
& MASKING

PERSONAL  
PROTECTION  
EQUIPMENT

TECHNICAL  
INFORMATION

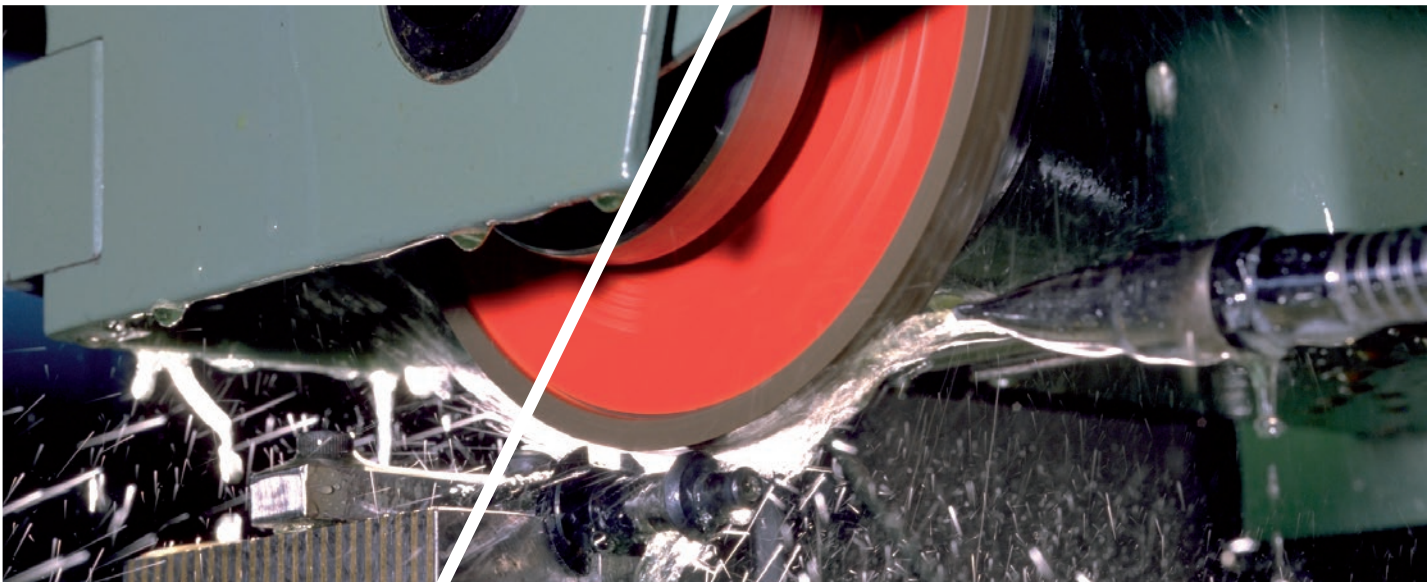



# GENERAL ENGINEERING

Norton offers a comprehensive stock programme for resin bonded 1A1 standard grinding wheels designed for OD- and flat grinding tungsten carbide and steel parts.

All specified grinding wheels can be used for OD- and flat grinding. However wheels (R50) with lower concentration have been specifically designed for flat grinding operations.

Other specifications are available on request.

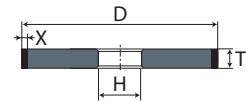
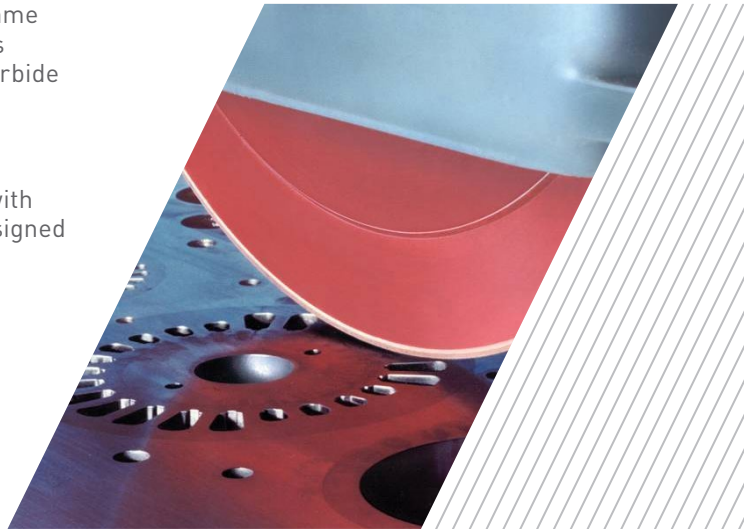

## 1A1 OD- AND FLAT GRINDING

D (mm)	T (mm)	X (mm)	H (mm)	PK QTY	SPECIFICATION	ART. NO.
<b>DIAMOND</b>						
175	15	3	32	1	ASD126 R50 B99	7958732730
200	10	3	32	1	ASD126 R75 B99	7958732731
	10	3	51	1	ASD126 R75 B99	7958732732
	15	3	32	1	ASD126 R75 B99	7958732840
250	15	3	76,2	1	ASD126 R75 B99	7958732804
300	10	3	127	1	ASD126 R75 B99	7958732824
	15	3	127	1	ASD126 R75 B99	7958732810
	20	3	127	1	AMD126 R50 B99	7958732812
350	15	3	127	1	ASD126 R50 B99	7958788919*
	20	3	127	1	ASD126 R50 B99	7958788920*
	30	3	127	1	ASD126 R50 B99	7958788921*
400	15	3	127	1	ASD126 R50 B99	7958788923*
	20	3	127	1	ASD126 R50 B99	7958788924*
	30	3	127	1	ASD126 R50 B99	7958788925*
<b>CBN</b>						
200	10	3	51	1	CB126 T B99	7958732803
	15	3	32	1	CB126 Q B99	7958732838
	15	3	76,2	1	CB126 T B99	7958732835
250	20	3	76,2	1	CB126 Q B99	7958732802
300	15	3	127	1	CB126 T B99	7958732808
	20	3	127	1	CB126 Q B99	7958732815
350	15	3	127	1	CB126 Q B99	7958788927*
	20	3	127	1	CB126 Q B99	7958788928*
	30	3	127	1	CB126 Q B99	7958788929*
400	15	3	127	1	CB126 Q B99	7958788930*
	20	3	127	1	CB126 Q B99	7958788932*
	30	3	127	1	CB126 Q B99	7958788933*

\* Made-to-order

SUPER  
ABRASIVES

DIAMOND  
TOOLS

CLEANING,  
POLISHING  
& MASKING

PERSONAL  
PROTECTION  
EQUIPMENT

TECHNICAL  
INFORMATION

# GENERAL ENGINEERING

Resin bonded grinding pins and grinding wheels can be used for wet or dry applications, either manually or on automatic grinding machines.

To avoid burning and to ensure stable grinding conditions the diameter must be carefully selected. It is highly recommended to chose a diameter no bigger than 70% of the bore. When using grinding pins it is very important to follow the permitted speed instructions, which are engraved on the grinding tool.

If the permitted speed is slower than the adjustable speed of the grinding spindle, a different technical solution is required.

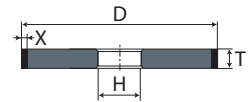

## 1A1 ID- GRINDING

D (mm)	T (mm)	X (mm)	H (mm)	PK QTY	SPECIFICATION	ART. NO.
<b>DIAMOND</b>						
15	12	2	6	1	ASD126 R100 B99	7958732728
20	10	2	6	1	ASD126 R100 B99	7958732950
25	10	2	6	1	ASD126 R75 B99	7958732942
30	10	3	6	1	ASD126 R75 B99	7958732952
	10	3	10	1	ASD126 R75 B99	7958732956
40	15	3	10	1	ASD126 R75 B99	7958732971
50	15	3	20	1	ASD126 R75 B99	7958732977
<b>CBN</b>						
12	10	2	6	1	CB126 W B99	7958732722
15	12	2	6	1	CB126 W B99	7958732729
20	10	2	6	1	CB126 W B99	7958732948
	15	2	6	1	CB126 W B99	7958732957
25	10	2	10	1	CB126 W B99	7958732945
	12	2	10	1	CB126 W B99	7958732939
30	15	3	10	1	CB126 W B99	7958732937
40	15	3	10	1	CB126 W B99	7958732961
50	15	3	20	1	CB126 W B99	7958732981

SUPER  
ABRASIVES

DIAMOND  
TOOLS

CLEANING,  
POLISHING  
& MASKING

PERSONAL  
PROTECTION  
EQUIPMENT

TECHNICAL  
INFORMATION

**1A1W ID-GRINDING**

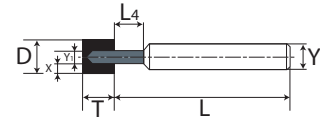

D (mm)	T (mm)	X (mm)	Y (mm)	L (mm)	Y <sub>1</sub> (mm)	L <sub>4</sub> (mm)	PK QTY	SPECIFICATION	ART. NO.
<b>DIAMOND</b>									
3	6	0,65	3	60	1,7	8	1	ASD64 R100 B99	7958732951
	6	0,65	3	60	1,7	8	1	ASD126 R100 B99	7958732949
5	6	1,5	3	60	2,1	8	1	ASD64 R100 B99	7958732944
	6	1,5	3	60	2,1	8	1	ASD126 R100 B99	7958732943
6	6	1,5	6	60	3,1	8	1	ASD64 R100 B99	7958732940
	6	1,5	6	60	3,1	8	1	ASD126 R100 B99	7958732941
8	10	2	6	60	4,1	12	1	ASD64 R100 B99	7958732954
	10	2	6	60	4,1	12	1	ASD126 R100 B99	7958732953
10	10	2	6	60			1	ASD64 R100 B99	7958732959
	10	2	6	60			1	ASD126 R100 B99	7958732960
12	12	2	6	60			1	ASD64 R100 B99	7958732963
	12	2	6	60			1	ASD126 R100 B99	7958732964
<b>CBN</b>									
3	6	0,65	3	60	1,7	8	1	CB126 W B99	7958732947
5	6	1,5	3	60	2,1	8	1	CB126 W B99	7958732946
6	6	1,5	6	60	3,1	8	1	CB126 W B99	7958732938
8	10	2	6	60	4,1	12	1	CB126 W B99	7958732955
10	10	2	6	60			1	CB126 W B99	7958732958
12	12	2	6	60			1	CB126 W B99	7958732962

SUPER  
ABRASIVES

DIAMOND  
TOOLS

CLEANING,  
POLISHING  
& MASKING

PERSONAL  
PROTECTION  
EQUIPMENT

TECHNICAL  
INFORMATION

# GENERAL ENGINEERING

Norton offers a small assortment of standard resin bonded cut-off grinding wheels (ex stock). The specified diamond cut-off wheels cut hard, short-chipping and wear resistant materials such as glass, ceramics and carbide. The contained CBN cut-off wheels are ideal for machining high speed steel, hardened steel, 55 HRC and magnetic materials.

Further specifications for resin bond, sintered metal and electroplated metal bond are available on request.

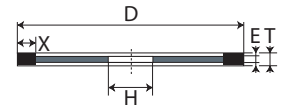
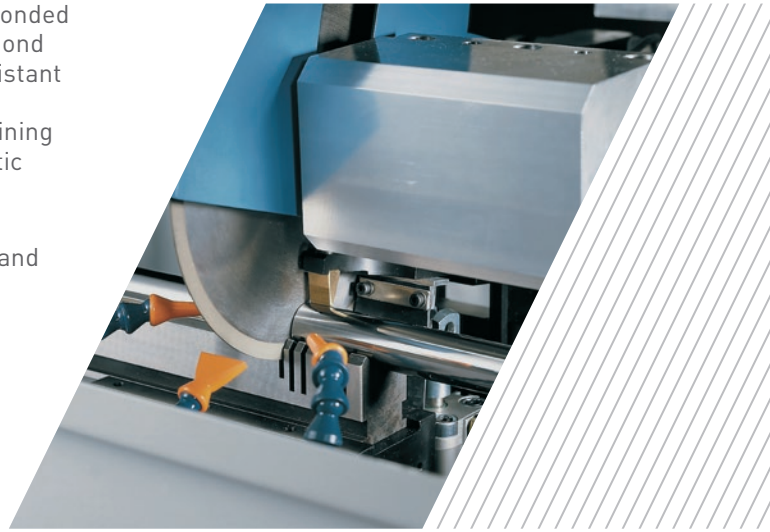

## 1A1R CUT-OFF

D (mm)	T (mm)	X (mm)	E (mm)	H (mm)	PK QTY	SPECIFICATION	ART. NO.
<b>DIAMOND</b>							
100	0,9	5	0,7	20	1	ASD126 R75 B99	60157681683
125	1	5	0,7	20	1	ASD126 R75 B99	60157681686
150	1	5	0,8	20	1	ASD126 R75 B99	60157681688
<b>CBN</b>							
100	0,9	5	0,7	20	1	CB151 T B99	60157681767
125	1	5	0,7	20	1	CB151 T B99	60157682094
150	1	5	0,8	20	1	CB151 T B99	60157682103

SUPER  
ABRASIVES

DIAMOND  
TOOLS

CLEANING,  
POLISHING  
& MASKING

PERSONAL  
PROTECTION  
EQUIPMENT

TECHNICAL  
INFORMATION

# GENERAL ENGINEERING KNIFE GRINDING

Norton offers a range of resin bonded grinding wheels for machining flat, circular and profile knives (ex stock).

The 6A2 grinding wheels are specifically designed for wet grinding of circular knives with tungsten carbide-steel combinations on Göckel and Reform machines.

The 14F1 grinding wheels are designed for use on Weing machines for grinding profile knives for the wood industry.

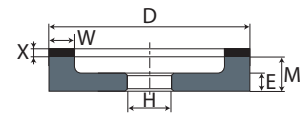

## 6A2 FLAT GRINDING

D (mm)	W (mm)	X (mm)	H (mm)	M (mm)	E (mm)	PK QTY	SPECIFICATION	ART. NO.	ADDITIONAL INFORMATION
<b>DIAMOND</b>									
200	8	4	50	31	23	1	AMD126 R100 B99	7958732926	For Göckel machines
	8	4	75	31	23	1	AMD126 R100 B99	7958732850	For Reform machines

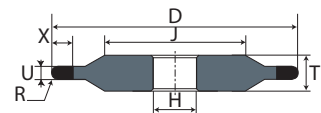

## 14F1 PROFILE GRINDING

D (mm)	U (mm)	X (mm)	R (mm)	H (mm)	T (mm)	J (mm)	PK QTY	SPECIFICATION	ART. NO.	ADDITIONAL INFORMATION
<b>DIAMOND</b>										
200	2	7	1	60	10	129	1	ASD64 R100 B99	7958732992	For Weing machines
	4	7	2	60	10	134	1	ASD151 R100 B99	7958732986	For Weing machines
<b>CBN</b>										
200	2	7	1	60	10	129	1	CB126 T B99	7958732990	For Weing machines
	4	7	2	60	10	134	1	CB151 W B99	7958732988	For Weing machines

SUPER ABRASIVES

DIAMOND TOOLS

CLEANING, POLISHING & MASKING

PERSONAL PROTECTION EQUIPMENT

TECHNICAL INFORMATION



# GENERAL ENGINEERING MILLING CUTTER

Grinding tool faces and clearances are the main applications of the milling cutter.

Norton offers a diverse range of grinding wheels to enable excellent performance in both applications. A comprehensive range of grit sizes and concentrations provides the ideal solution for each application (ex stock).

The price vs. performance ratio of these tools is the underlying benefit of this product range.

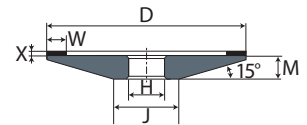
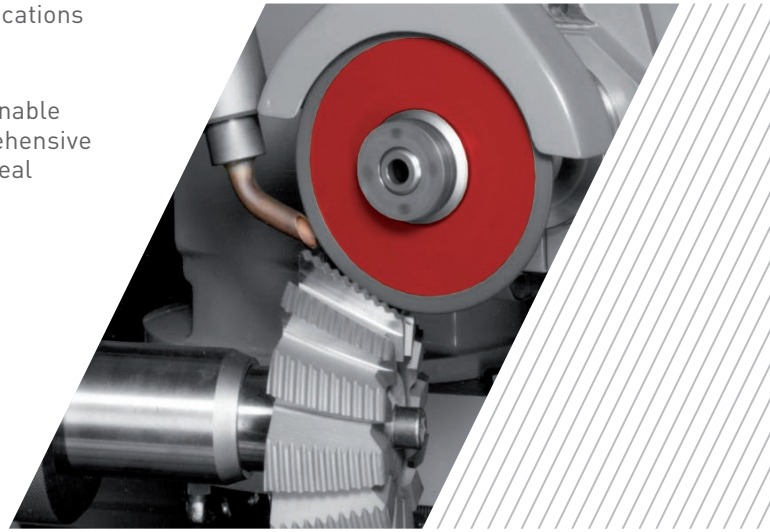

## 4A2 FACE GRINDING

D (mm)	W (mm)	X (mm)	H (mm)	M (mm)	J (mm)	PK QTY	SPECIFICATION	ART. NO.
<b>DIAMOND</b>								
100	5	2	20	6	66	1	ASD64 R75 B99	7958732965
125	5	2	20	7	84	1	ASD64 R75 B99	7958732868
	5	2	20	7	84	1	ASD126 R75 B99	7958732870
	5	2	32	7	84	1	ASD91 R75 B99	7958732866
	10	2	20	7	84	1	ASD107 R75 B99	7958732873
	5	2	20	9	94	1	ASD64 R75 B99	7958732863
150	5	2	20	9	94	1	ASD126 R75 B99	7958732864
	5	2	32	9	94	1	ASD54 R50 B99	7958732858
	5	2	32	9	94	1	ASD91 R75 B99	7958732855
	3	3,3	20	9	94	1	ASD64 R75 B49	66260120336
	5	2	32	9	94	1	ASD126 R75 B99	7958732929
175	5	4	32	11	104	1	ASD126 R75 B99	7958732929
<b>CBN</b>								
100	5	2	20	6	66	1	CB126 T B99	7958732884
150	5	4	20	9	94	1	CB107 T B99	7958732852
	3	3,3	20	9	94	1	CB107 R75 B49	66260120370
175	5	4	20	11	104	1	CB126 T B99	7958733000

SUPER  
ABRASIVES

DIAMOND  
TOOLS

CLEANING,  
POLISHING  
& MASKING

PERSONAL  
PROTECTION  
EQUIPMENT

TECHNICAL  
INFORMATION

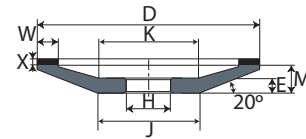

**12A2-20° FACE GRINDING**

D (mm)	W (mm)	X (mm)	H (mm)	M (mm)	K (mm)	E (mm)	J (mm)	PK QTY	SPECIFICATION	ART. NO.
<b>DIAMOND</b>										
125	5	2	20	14	54	8	54	1	ASD126 R75 B99	69014151721
	6	4	20	14	54	8	54	1	ASD126 R100 B99	60157682171
	6	4	32	14	54	8	54	1	ASD91 R75 B99	60157682172
150	5	2	20	16	68	9	68	1	ASD64 R50 B99	69014151397
	5	2	20	16	68	9	68	1	ASD126 R75 B99	69014151961
	5	2	32	16	68	9	68	1	ASD126 R75 B99	69014151963
	5	3	32	16	68	9	68	1	ASD64 R100 B99	60157682177
	5	3	32	16	68	9	68	1	ASD91 R100 B99	60157682176
	6	4	32	16	68	9	68	1	ASD91 R75 B99	60157682179
175	5	2	20	18	82	10	82	1	ASD126 R75 B99	69014151422
	5	2	32	18	82	10	82	1	ASD126 R75 B99	69014151424
<b>CBN</b>										
150	5	4	20	16	68	9	68	1	CB126 Q B99	69014151412
	6	4	32	16	68	9	68	1	CB126 T B99	60157682182
175	5	4	20	18	82	10	82	1	CB126 T B99	69014151427

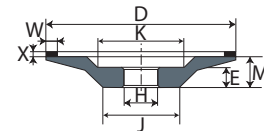

**13A2 FACE GRINDING**

D (mm)	W (mm)	X (mm)	H (mm)	M (mm)	K (mm)	E (mm)	J (mm)	PK QTY	SPECIFICATION	ART. NO.
<b>DIAMOND</b>										
125	5	4	20	19	50	9	73	1	ASD64 R50 B99	7958732980
	5	4	20	19	50	9	73	1	ASD126 R50 B99	7958732995
	5	4	20	19	50	9	73	1	ASD126 R75 B99	7958732991
	5	4	20	18	50	9	73	1	ASD64 R50 B49	66260120331
	5	4	20	18	50	9	73	1	ASD181 R50 B49	66260120332
150	5	4	20	20	75	11	95	1	ASD64 R50 B49	66260120333
<b>CBN</b>										
125	5	4	20	19	50	9	73	1	CB64 Q B99	7958732973
	5	4	20	19	50	9	73	1	CB107 Q B99	7958732979
	5	4	20	19	50	9	73	1	CB151 Q B99	7958732978
	5	4	20	18	50	9	73	1	CB64 R50 B49	66260120367
150	5	4	20	20	75	11	95	1	CB126 R50 B49	66260120368
175	5	4	20	22	75	11	95	1	CB126 R50 B49	66260120369

SUPER  
ABRASIVES

DIAMOND  
TOOLS

CLEANING,  
POLISHING  
& MASKING

PERSONAL  
PROTECTION  
EQUIPMENT

TECHNICAL  
INFORMATION

## 12A2-45° TOP GRINDING

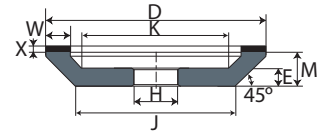

D (mm)	W (mm)	X (mm)	H (mm)	M (mm)	K (mm)	E (mm)	J (mm)	PK QTY	SPECIFICATION	ART. NO.
<b>DIAMOND</b>										
100	5	2	20	23	54	10	56	1	ASD107 R50 B99	7958732999
	6	3	20	20	64	10	62	1	ASD76 R75 B99	7958732968
	6	3	20	20	64	10	62	1	ASD126 R75 B99	7958732966
125	6	3	32	23	83	10	81	1	ASD126 R75 B99	7958732969
<b>CBN</b>										
100	5	2	20	23	54	10	56	1	CB126 Q B99	7958732997
125	6	2	20	23	83	10	81	1	CB126 T B99	7958732970

## GENERAL ENGINEERING DIAMOND LAPPING COMPOUNDS

Norton lapping compounds are supplied in a standard concentration of 5g dispenser syringes. Perfectly sized synthetic diamond powder is mixed with a paste. When used, this compound should be diluted with water or alcohol.

### APPLICATIONS & MARKETS

- Used for lapping an extremely wide range of parts by hand
- Superfinishing of electronic components, semi-conductors, magnetic heads, rigid discs and optical discs
- Finishing for routine operations
- Preparatory lapping
- Fast removal of material, roughing



## DIAMOND COMPOUND PASTE



### FEATURES

- Optimised diamond grit distribution

### BENEFITS

- Easy and safe application

GRADE (MICRONS)	COLOUR	CONTENTS	PK QTY	ART. NO.
1/4	GREY	5g	1	69014154990
1/2	LIGHT GREY	5g	1	69014154991
1	IVORY	5g	1	69014154992
3	YELLOW	5g	1	69014154993
6	ORANGE	5g	1	69014154994
9	GREEN	5g	1	69014154995
12	LIGHT BLUE	5g	1	69014154996
15	BLUE	5g	1	69014154997
20	BROWN	5g	1	69014154998
30	RED	5g	1	69014154999
45	CHESTNUT	5g	1	69014155000
60	VIOLET	5g	1	69014155001

SUPER ABRASIVES

DIAMOND TOOLS

CLEANING, POLISHING & MASKING

PERSONAL PROTECTION EQUIPMENT

TECHNICAL INFORMATION

# GENERAL ENGINEERING DIAMOND FILES

Norton offers a range of diamond files in various shapes.

## APPLICATIONS & MARKETS

- Deburring
- Tool profiling
- Touching up hardened steels and metal carbides
- Glass
- Ceramics
- Hard plastics



## FILES







### FEATURES

- Several shapes available

### BENEFITS

- Free cutting and very high wear resistant, requiring only low contact pressure

SHAPE	T (mm)	H (mm)	L (mm)	PK QTY	ART. NO.
	1,4	4,8	140	6	60157636812
	1,9	5,3	140	6	60157636813
	3,6	3,6	140	6	60157636814*
	2,5	2,5	140	6	60157636815*
	1,4	4,8	140	6	60157636817*
Set - all above				6	60157636811*

\* Made-to-order

**Dimensions Key:** T = Thickness, H = Height, L = Length



# DIAMOND DRESSERS

Norton stationary diamond dressing tools have a worldwide reputation for quality and technology.

## APPLICATIONS & MARKETS

- For the profiling and straight dressing of all conventional grinding wheels



## PRODUCT SELECTION

Usage Key ● Highly recommended ○ Recommended	GENERAL CHOICE					
	STRAIGHT GRINDING WHEELS WITH NO PROFILE	PROFILED GRINDING WHEELS	GRIT	AUTOMATIC DRESSING PROCESS	ECONOMICAL DRESSING	HIGH REMOVAL RATE
DRESSING TOOL						
Single-point	○		All			
Multi-point	●		36-180		●	●
Blade tool dresser	●	○	36-180	●	●	○
Profile dresser		●	80-180			



### SPEC CHECK

- A new dressing tool should be put through at least 5 dressing cycles in order to fit the diameter of the grinding wheel
- The lifetime of the dressing tool is extended by ensuring that adequate coolant pressure and volume are directed at the tool.

SUPER ABRASIVES

DIAMOND TOOLS

CLEANING, POLISHING & MASKING

PERSONAL PROTECTION EQUIPMENT

TECHNICAL INFORMATION

## SELECTION OF BLADE TOOL DRESSERS

Dressing of profiles with blade tools	Dressing tools use a 'needle' form of natural or synthetic diamonds. Needle diamonds are especially suited to dressing profiles using infeeds and angular feeds.
Natural diamonds	An effective diamond layer with a length of up to 15mm creates an economical dressing solution. Using precise diamond setting patterns, with overlapped rows of stones, ensures that consistent dressing results are achieved.
Synthetic diamonds	The constant cross section given by synthetic diamonds, guarantees a constant dressing behaviour through the complete life of the dressing tool.

SELECTION OF GRIT SIZE		
Grit size of grinding wheel	Synthetic diamond size	Natural diamond size
46	0,8x0,8	D1181
60	0,8x0,8	D1001
80-120	0,6x0,6	D711

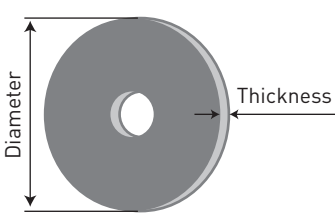
SELECTION OF TOOL SIZE			
	Diameter x Thickness (mm)	No. of synthetic needles	Dimensions
	<35000	2	10,5x28
	35000-60000	3	20,5x28
	60000-100000	4	20,5x28

## CHOICE OF SINGLE-POINT DRESSERS

Which tool to choose depends mainly on the dimensions of the wheel to be dressed. In order to calculate this, it is best to use the following method:

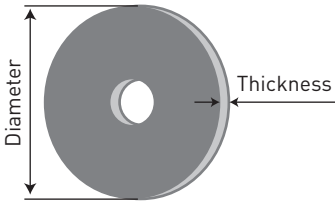
MULTIPLY THE DIAMETER OF THE WHEEL BY ITS THICKNESS		
	Diameter x Thickness (mm)	Carat
	< 6000	0,33 Carat
	6000 - 18000	0,50 Carat
	> 18000	1,0 Carat

For best results, always use a coolant when dressing

## BLADE TOOL DRESSERS HPB-D 3565 & 3585

**BEST +++++**

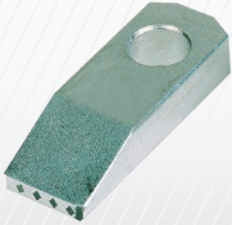

### FEATURES

- Synthetic multi-crystalline diamond

### BENEFITS

- Gives the most repeatable and consistent dresser for the highest demands in profiling and straight dressing

W (mm)	L (mm)	DL (mm)	GRIT	PK QTY	SPECIFICATION	ART. NO.
10,5	28	4	0,6x0,6	1	HPB-D 3565 / 2	60157682820
	28	4	0,6x0,6	1	HPB-D 3565 / 3	60157682856
	28	4	0,6x0,6	1	HPB-D 3565 / 4	60157682895
	28	4	0,8x0,8	1	HPB-D 3585 / 2	60157682899
	28	4	0,8x0,8	1	HPB-D 3585 / 3	60157682902
	28	4	0,8x0,8	1	HPB-D 3585 / 4	60157682904

## BLADE TOOL DRESSERS HPB-D & -C 30, 45, 60

**BETTER ++++**



### FEATURES

- Natural diamond

### BENEFITS

- An economical dressing solution for all Alox and SiC wheels. Needles are recommended for profile dressing

W (mm)	L (mm)	DL (mm)	GRIT	PK QTY	SPECIFICATION	ART. NO.
10,5	28	12	D711	1	HPB-D 30	60157682759*
	28	12	D1001	1	HPB-D 45	60157682782
	28	12	D1181	1	HPB-D 60	60157682786
	28	12	NEEDLE	1	HPB-D	60157682790
20,5	28	10	D711	1	HPB-C 30	60157682801
	28	10	D1001	1	HPB-C 45	60157682806
	28	10	D1181	1	HPB-C 60	60157682809
	28	10	NEEDLE	1	HPB-C	60157682814

\* Made-to-order

## SCREWED SHANKS FOR BLADE TOOL DRESSERS

DIA (mm)	L (mm)	SHANK CODE	PK QTY	BEST
12,065	40	MT1	1	HPB-H3 60157682832
9,045	25,5	MT0	1	HPB-H4 60157682907
11,11	50	Z11,11	1	HPB-H2 60157682910
10,00	50	Z10	1	HPB-HX 60157682911

**Dimensions Key:** DIA = Diameter, W = Width, L = Length, DL = Diamond Length

SUPER ABRASIVES

DIAMOND TOOLS

CLEANING, POLISHING & MASKING

PERSONAL PROTECTION EQUIPMENT

TECHNICAL INFORMATION

## SINGLE-POINT DRESSER BC SG

BEST +++++



## FEATURES

- Highest quality diamonds
- High performance tools

## BENEFITS

- Specifically developed for dressing ceramic abrasive (SG/TG) wheels which require faster traverse speed dressing
- Enables dressing costs to be reduced, especially at production grinding stations

SHANK (mm)	CARAT	PK QTY	ART. NO.
Z8	0,50	1	66260161757
	1,00	1	66260161755
Z10	0,33	1	66260161769
	0,50	1	66260161768
	1,00	1	66260161766
Z11,11	0,33	1	66260156906
	0,50	1	66260156907
	1,00	1	66260157010
Z12	0,50	1	66260161779
	1,00	1	66260161777

## SINGLE-POINT DRESSER BC (CYLINDRICAL SHANK)

BETTER ++++



## FEATURES

- Standard diamonds
- Economy product

## BENEFITS

- Ideal for applications where it is difficult to measure the performance of the dressing tool
- Suitable for dressing conventional abrasive wheels

SHANK (mm)	CARAT	PK QTY	ART. NO.
Z8	0,33	1	66260161753
	0,50	1	66260161752
	1,00	1	66260161750
Z10	0,33	1	66260161764
	0,50	1	66260161763
	1,00	1	66260161761
Z11,11	0,33	1	66260195003
	0,50	1	66260195005
	1,00	1	66260195009
Z12	0,33	1	66260161775
	0,50	1	66260161774

## SINGLE-POINT DRESSER SP (MK- SHANK)

**GOOD +++**



### FEATURES

- Commercial standard diamonds

### BENEFITS

- Standard dresser for conventional abrasive wheels

SHANK (mm)	CARAT	PK QTY	ART. NO.
MK0	0,3	1	69014119596
	0,5	1	69014119598
	1,0	1	69014119599
	1,5	1	69014119600
MK1	0,3	1	69014119570
	0,5	1	69014119591
	1,0	1	69014119594
	1,5	1	69014119595

## PROFILE DRESSER

**BEST +++++**



### FEATURES

- Extremely high performance tools

### BENEFITS

- Used to meet extremely high profile accuracy requirements

SHANK (mm)	RADIUS (mm)	ANGLE	SPECIFICATION	ART. NO.
Z9,52	0,13	40°	DC 40/130	60157682850
	0,25	40°	DC 40/250	60157682889
	0,50	40°	DC 40/500	60157682901
	0,13	60°	DC 60/130	60157682903
	0,25	60°	DC 60/250	60157682905
	0,50	60°	DC 60/500	60157682909

SUPER ABRASIVES

DIAMOND TOOLS

CLEANING, POLISHING & MASKING

PERSONAL PROTECTION EQUIPMENT

TECHNICAL INFORMATION



## CHOICE OF MULTI-POINT DRESSERS

Which tool to choose depends mainly on the dimensions of the wheel to be dressed.  
In order to calculate this, it is best to use the following method:

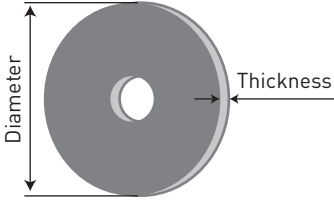
MULTIPLY THE DIAMETER OF THE WHEEL BY ITS THICKNESS		
	Diameter x Thickness (mm)	Carat
	< 30000	1,3 Carat
	30000 – 60000	2,5 Carat
	> 60000	5,0 Carat

For best results, always use a coolant when dressing

CHOICE OF DIAMOND GRIT	
Wheel abrasive	Diamond
80-120	D301
60-80	D711
46-60	D1001
36-46	D2240

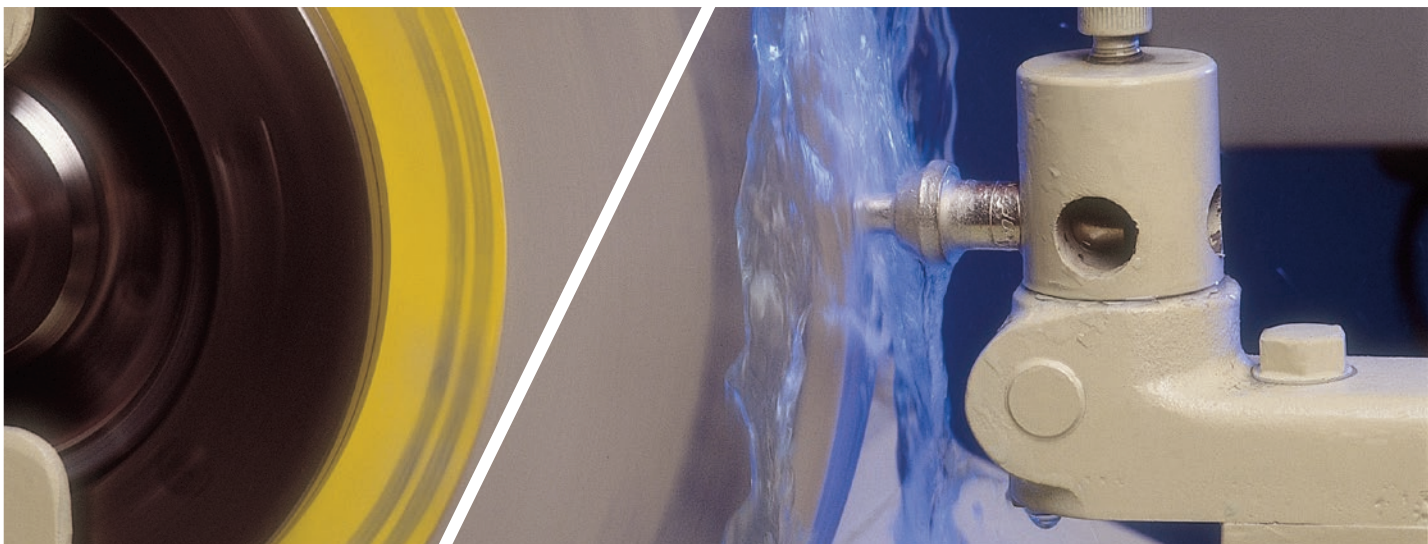

# MULTI-POINT DRESSER

**BEST +++++**



### FEATURES

- Economical and robust tool

### BENEFITS

- Ideal for straight dressing at high speed with low technical demands

TYPE	SHANK (mm)	GRIT	PK QTY	ART. NO.
D11X11 (5 CARAT)	Z8	D2240	1	60157682849
		D1001	1	60157682896
		D711	1	60157682906
	Z10	D2240	1	60157682892
		D1001	1	60157682897
		D711	1	60157682908
	Z11,11	D2240	1	60157682893
		D1001	1	60157682898
		D711	1	60157682912
	MT1 12,065	D2240	1	60157682894
		D1001	1	60157682900
		D711	1	60157682914
D8X11 (2,5 CARAT)	Z8	D2240	1	60157682915
		D1001	1	60157682920
		D711	1	60157682970
	Z10	D2240	1	60157682916
		D1001	1	60157682922
		D711	1	60157682968
	Z11,11	D2240	1	60157682917
		D1001	1	60157682923
		D711	1	60157682977
	MT1 12,065	D2240	1	60157682918
		D1001	1	60157682925
		D711	1	60157682981
D6X8 (1,3 CARAT)	Z8	D711	1	60157682986
		D301	1	60157683153
	Z10	D711	1	60157682990
		D301	1	60157683154
	Z11,11	D711	1	60157682992
		D301	1	60157683155
	MT1 12,065	D711	1	60157682996
		D301	1	60157683156

SUPER ABRASIVES

DIAMOND TOOLS

CLEANING, POLISHING & MASKING

PERSONAL PROTECTION EQUIPMENT

TECHNICAL INFORMATION

## HAND DRESSER



### FEATURES

- High diamond concentration
- Grit 18/25 SPC

### BENEFITS

- High wear resistance and long product life time
- Suitable for face and side dressing

PK QTY	SPECIFICATION	ART. NO.
1	HD-150	60157682852

## BRAKE CONTROLLED TRUING DEVICE



### FEATURES

- For fast effective truing of Diamond and CBN wheels with minimum loss of abrasive

### BENEFITS

- Ideal for truing the following diamond and CBN wheel types: straight wheels with diamond in the periphery, tool and cutter grinding wheels, wheels used on surface and cylindrical grinding machines, cut-off wheels and internal grinding wheels and cup wheels with diamonds in the rim, as used on vertical spindle surface grinders

PK QTY	SPECIFICATION	ART. NO.
1	BCTD	66260274459

SUPER ABRASIVES

DIAMOND TOOLS

CLEANING, POLISHING & MASKING

PERSONAL PROTECTION EQUIPMENT

TECHNICAL INFORMATION

## REPLACEMENT WHEELS

DIA (mm)	T (mm)	B (mm)	PK QTY	BEST
80	25	13	10	Wheel 37C60-NV 69936668764

**Dimensions Key:** DIA = Diameter, T = Thickness, B = Bore



### SPEC CHECK

- Mount the device spindle parallel to the wheel spindle to ensure correct straight face truing
- For cup shaped wheels, the device spindle will be mounted perpendicularly to the wheel spindle
- Use appropriate traverse rates.

# 435-462 DIAMOND TOOLS



436 Introduction  
442 Angle Grinders

449 Petrol Hand Held  
& Floor Saws  
452 Masonry Saws

456 Tile Saws  
458 Core Bits

DIAMOND  
TOOLS

CLEANING,  
POLISHING  
& MASKING

PERSONAL  
PROTECTION  
EQUIPMENT

TECHNICAL  
INFORMATION



# INTRODUCTION

Norton Clipper Diamond Blades are the ultimate abrasive cutting solution in construction and building industries. With a range of products suitable for use on concrete, tile, brick, and asphalt, Norton Clipper offers the best choice for every cutting and drilling application in the building/construction industry.



## UNDERSTANDING THE PRODUCT

- 1 Safety pictograms
- 2 Strong Norton Clipper branding
- 3 Product name
- 4 Product dimensions (mm)
- 5 Machine type
- 6 oSa certified  
The Organisation for Safety of Abrasives
- 7 European safety standard EN13236:2010

## DIFFERENTIATION IN THE RANGE

Norton offers the industry's widest selection of diamond blades to meet every customer requirement. The range is classified into three quality-tiers (best/better/good) to help you choose the right product for your specific application.

BEST <b>+++++</b>	<b>EXTREME</b>	The Norton Clipper Extreme product range offers high performance; fast cutting and long blade life, for heavy usage, to meet the need of the most demanding applications.
BETTER <b>++++</b>	<b>PRO</b>	Norton Clipper Pro is a professional quality range designed for frequent use. The Pro range offers great performance in speed of cut and blade life.
GOOD <b>+++</b>	<b>CLASSIC</b>	Norton Clipper Classic is a range of standard diamond tools for low frequency use, providing a good quality to performance ratio.



# APPLICATIONS KEY - DIAMOND BLADES

Choosing the right diamond tool for the job is not always straight forward. For this reason Norton Clipper diamond blades are colour coded to ensure you pick the most appropriate tool for the job.

	BEST INNOVATION	BEST	BETTER	GOOD
<p>MULTI-PURPOSE</p>			4x4 EXPLORER	
<p>CONCRETE &amp; REINFORCED CONCRETE</p>	EXTREME BETON SILENCIO			
<p>ASPHALT &amp; ABRASIVE MATERIALS</p>			PRO ASPHALT	
<p>UNIVERSAL BUILDING MATERIALS</p>	EXTREME UNIVERSAL SILENCIO	EXTREME UNIVERSAL TURBO, EXTREME UNIVERSAL LASER	PRO UNIVERSAL TURBO, PRO UNIVERSAL TP, PRO UNIVERSAL LASER, PRO UNIVERSAL	CLASSIC UNIVERSAL TURBO, CLASSIC UNIVERSAL LASER, CLASSIC UNIVERSAL
<p>CERAM</p>	EXTREME CERAM TURBO	EXTREME CERAM TURBO	PRO CERAM	CLASSIC CERAM

For further information please go to the Technical Information Section at the back of this catalogue.

DIAMOND TOOLS

CLEANING, POLISHING & MASKING

PERSONAL PROTECTION EQUIPMENT

TECHNICAL INFORMATION

# PRODUCT SELECTION - ANGLE GRINDERS

Usage Key	INNOVATION	EXTREME BETON SILENCIO	EXTREME CERAM TURBO	4x4 EXPLORER	EXTREME UNIVERSAL TURBO	PRO UNIVERSAL TURBO	PRO UNIVERSAL TP	PRO UNIVERSAL LASER	CLASSIC UNIVERSAL TURBO	CLASSIC UNIVERSAL LASER	CLASSIC UNIVERSAL	PRO CERAM	CLASSIC CERAM
<ul style="list-style-type: none"> <li>● Highly recommended</li> <li>○ Recommended</li> </ul> 													
Steel				●									
Granite		●	●	○	●							○	
Engineering bricks		●		○	●	●		○					
Cured concrete		●		●	●	○		●	○	●	○		
Clay/pipes/paviors		●		○	●	●						○	
Quarry tiles			●		○							●	○
Marble		○	○		●	●						○	○
Hard paviors		●		●	●	●		●	○	●	○		
Clay roof tiles		○		○	●	●		○	○	○	○		
Terrazo			●		○							●	
Facing bricks		●	○	○	●	●		●	○	○	○	○	
Reinforced concrete		●		○	○	○		●	○	●	○		
Concrete paving slabs		●		●	●	○		●	○	●	○		
Concrete pipes/kerbs		●		●	●	●		●	○	●	○		
Slate			●		●	●						●	○
Limestone concrete		●		●	○	○		●	○	○	○		
Medium block paviors		●		●	●	○		●	○	●	○		
Concrete roof tiles		○		●	●	●		●	○	●	○		
Sandstone		●		○									
Asphalt over concrete				●									
Breeze blocks				●				●					
Tarmac top blocks				○									
Mortar jointing							●						
Asphalt				○									

DIAMOND TOOLS

CLEANING, POLISHING & MASKING

PERSONAL PROTECTION EQUIPMENT

TECHNICAL INFORMATION

## PRODUCT SELECTION - PETROL HAND HELD & FLOOR SAWS

Usage Key ● Highly recommended ○ Recommended 	EXTREME BETON SILENCIO	4x4 EXPLORER	PRO ASPHALT
	BEST	BETTER	
Steel		○	
Granite	●	○	
Engineering bricks	●	○	
Cured concrete	●	●	
Clay/pipes/paviors	●	○	
Marble	○		
Hard paviors	●	●	
Clay roof tiles	○	○	
Facing bricks	●	○	
Reinforced concrete	●	○	
Concrete paving slabs	●	●	
Concrete pipes/kerbs	●	●	
Limestone concrete	●	●	
Medium block paviors	●	●	
Concrete roof tiles	○	●	
Sandstone	●	○	●
Asphalt over concrete		●	●
Breeze blocks		●	●
Tarmac top blocks		○	●
Asphalt		●	●
Green concrete			○

DIAMOND TOOLS

CLEANING, POLISHING & MASKING

PERSONAL PROTECTION EQUIPMENT

TECHNICAL INFORMATION



## PRODUCT SELECTION - MASONRY SAWS

Usage Key ● Highly recommended ○ Recommended 	EXTREME UNIVERSAL SILENCIO	EXTREME UNIVERSAL LASER	PRO UNIVERSAL LASER	PRO UNIVERSAL	4x4 EXPLORER	EXTREME CERAM TURBO	PRO CERAM
	BEST		BETTER			BEST	BETTER
Steel					○		
Granite	●	○			○	●	○
Engineering bricks	●	○	○		○		
Cured concrete	●	●		○	●		
Clay/pipes/paviors	●	○			○		○
Quarry tiles		○				●	○
Marble	○	○				○	●
Hard paviors	●	○		○	●		
Clay roof tiles	○	○		○	○		
Terrazo		○	○			●	●
Facing bricks	●	●		●	○	○	
Reinforced concrete	●	●	●		○		
Concrete paving slabs	●	○	●	○	●		
Concrete pipes/kerbs	●	●		●	●	●	
Slate		●	○			●	●
Limestone concrete	●	●	○	●	●		
Medium block paviors	●	●		●	●		
Concrete roof tiles	○	●		○	●		
Sandstone	●	○		○	○		
Asphalt over concrete					●		
Breeze blocks					●		
Tarmac top blocks					○		
Asphalt					○		

## PRODUCT SELECTION - TILE SAWS

Usage Key ● Highly recommended ○ Recommended 	EXTREME CERAM TURBO	PRO CERAM	CLASSIC CERAM
	BEST	BETTER	GOOD
Granite	○	○	
Clay/pipes/paviors	●	○	
Quarry tiles	●	○	○
Marble	○	●	○
Terrazo	●	●	
Slate	●	●	○

## PRODUCT SELECTION - CORE BITS

Usage Key ● Highly recommended ○ Recommended 	CORE BITS 	EXTREME CB UNIVERSAL	PRO CB UNIVERSAL	CLASSIC CB UNIVERSAL	CLASSIC ARID DS	CORE BITS 	PRO CB BETON CROWNED	PRO CB BETON SEGMENTED	CLASSIC CB BETON
Cured concrete		●	●	○	○		●	●	●
Hard paviors		●	○	○	○		○	●	○
Reinforced concrete								●	○
Concrete paving slabs		○	●	●				●	
Medium block paviors		○	●	●	○		○	●	○
Asphalt		○	○	○				○	

DIAMOND TOOLS

CLEANING, POLISHING & MASKING

PERSONAL PROTECTION EQUIPMENT

TECHNICAL INFORMATION



# DIAMOND BLADES FOR ANGLE GRINDERS

Norton Clipper diamond blades offer the user a cost-effective range of safe, easy to use products designed for use on all common types of building materials.

## APPLICATIONS & MARKETS

- Construction
- Renovation
- Maintenance
- Tiling
- Plumbing
- Engineering



## EXTREME BETON SILENCIO

BEST +++++

INNOVATION



**SILENCIO**

For use on engineering bricks, cured concrete, reinforced concrete, hard paviors, concrete paving slabs, concrete kerbs, concrete pipes, limestone, medium block paviors, & facing bricks.

### FEATURES

- Sandwich steel-centre with newly developed absorbing material
- Patented offset gullets prevent air from flowing through the steel-centre gullets
- Up to 17mm high segments, with a bespoke specification for each different application

### BENEFITS

- The Norton Clipper Silencio features unprecedented noise-dampening effect, reaching reductions of up to -11db - 15 times less noise !!
- The blade does not whistle at all while running idle, for a much better comfort of the operator and the surrounding area
- The Norton Silencio is among the best cutting Clipper diamond blades. Select the blade specifically designed for your machine type to get the best cutting performance

**15x**  
LESS NOISE

DIA (mm)	HxTxB (mm)	PK QTY	ART. NO.
230	17,0x2,8x22,23	1	70184601168

DIAMOND TOOLS

CLEANING, POLISHING & MASKING

PERSONAL PROTECTION EQUIPMENT

TECHNICAL INFORMATION

## 4X4 EXPLORER

BETTER ++++



**4X4 EXPLORER**



For use on granite, engineering bricks, hard paviors, reinforced concrete, concrete kerbs & slabs, medium block paviors, facing brick, concrete roof tiles, sandstone, asphalt over concrete & asphalt.

### FEATURES

- 12mm high segments with new specification
- Trapezoidal shape segments
- Patented drop-shape gullet
- Smarter diamond blade with segment wear-indicator and cutting depth indicator

### BENEFITS

- Up to 40% faster cut in concrete  
Up to 20% longer life
- Ensure narrowest possible space between each segments for reduces vibrations and better comfort
- Better resistance to cracks for enhanced safety. Norton Clipper 4x4 Explorer can cut in metal (up to 5mm thickness).
- Easier mounting, depth control while cutting and better follow up of the product life

DIA (mm)	HxTxB (mm)	PK QTY	ART. NO.
115	10,0x2,2x22,23	1	70184602018
125	10,0x2,2x22,23	1	70184602019
180	10,0x2,5x22,23	1	70184602020
230	12,0x2,5x22,23	1	70184602021

**Dimensions Key:** DIA = Diameter, H = Height, T = Thickness, B = Bore

# DIAMOND BLADES FOR ANGLE GRINDERS

## EXTREME UNIVERSAL TURBO

BEST +++++



Suitable for use on very hard masonry materials, block paviors, granite & marble.

### FEATURES

- Special blade geometry
- Protection segments
- Ventilated steel centre
- Heavy duty diamond blade
- Sintered, continuous rim diamond blade with corrugated steel centre

### BENEFITS

- Gives more rigidity
- Protect the steel centre & provide outstanding rigidity
- Provides efficient cooling during cutting
- Has extreme long life & an excellent cutting speed

## PRO UNIVERSAL TURBO

BETTER ++++



Suitable for use with engineering bricks, clay pipes/paviors, marble, clay roof tiles, concrete pipes/kerbs, slate, hard paviors, facing bricks, concrete roof tiles, medium block paviors, breeze blocks & concrete paving slabs.

### FEATURES

- 12mm segment height
- High-quality diamond blade
- Sintered, corrugated continuous rim diamond blade

### BENEFITS

- Longer life
- Long life, excellent cutting speed & all round excellent performance

## PRO UNIVERSAL TP



Suitable for removing mortar prior to the rejoining of brick walls.

### FEATURES

- Brazed, segmented diamond blade especially designed for the removal of mortar prior to rejoining
- Tungsten carbide tips

### BENEFITS

- Premium performance
- Gives undercutting protection

## PRO UNIVERSAL LASER



For use on cured concrete, hard paviers, facing bricks, concrete paving slabs, concrete kerbs, concrete pipes, limestone, medium block paviers, concrete roof tiles & breeze blocks.

### FEATURES

- 10mm segment height
- Diamond-shape apertures on 230mm diamond blades
- Laser-welded, segmented diamond blade

### BENEFITS

- Longer life
- Prevent over-heating of the diamond blade

# DIAMOND BLADES FOR ANGLE GRINDERS

GOOD +++

## CLASSIC UNIVERSAL TURBO



For use on engineering bricks, clay pipes/paviors, clay roof tiles, concrete pipes/kerbs, facing bricks, concrete roof tiles, medium block paviors, breeze blocks & concrete paving slabs.

### FEATURES

- Economy diamond blade
- Sintered, continuous rim diamond blade with corrugated segments

### BENEFITS

- Value for money

## CLASSIC UNIVERSAL LASER



Cured concrete, concrete pipes, concrete kerbs, hard paviors, roof tiles, medium block paviors, concrete paving slabs.

### FEATURES

- Economy diamond blade
- Laser-welded, segmented diamond blade

### BENEFITS

- Value for money

## CLASSIC UNIVERSAL



For use on concrete pipes, concrete kerbs, roof tiles, medium block paviors & concrete paving slabs.

### FEATURES

- Economy diamond blade
- Sintered, segmented diamond blade

### BENEFITS

- Value for money
- Recommended for soft to medium hard materials.  
Not recommended for very hard materials

DIAMOND TOOLS

CLEANING, POLISHING & MASKING

PERSONAL PROTECTION EQUIPMENT

TECHNICAL INFORMATION



## UNIVERSAL BUILDING MATERIALS



DIA (mm)	HxTxB (mm)	PK QTY	EXTREME UNI TURBO	PRO UNI TURBO	PRO UNI TP	PRO UNI LASER
			BEST	BETTER		
115	12,0x2,2x22,23	1	70184623598			
	10,0x2,2x22,23	1		70184610314		70184624738
	6,5x4,5x22,23	1			70184610712	
	6,5x6,5x22,23	1			70184610305	
125	12,0x2,2x22,23	1	70184623599			
	10,0x2,1x22,23	1		70184610315		
	10,0x2,2x22,23	1				70184624739
	6,5x4,5x22,23	1			70184610713	
	6,5x6,5x22,23	1			70184610307	
	6,5x8,0x22,23	1			70184610716	
180	10,0x2,5x22,23	1				70184625563
	7,0x2,2x22,23	1		70184610317		
230	12,0x2,8x22,23	1	70184623180			
	10,0x2,5x22,23	1				70184611396
	10,0x2,6x22,23	1		70184610267		



## UNIVERSAL BUILDING MATERIALS



DIA (mm)	HxTxB (mm)	PK QTY	CLASSIC UNI TURBO	CLASSIC UNI LASER	CLASSIC UNI
			GOOD		
115	10,0x1,8x22,23	1			70184626806
	10,0x2,1x22,23	1	70184626814		
	7,0x2,2x22,23	1		70184626834	
125	10,0x1,8x22,23	1			70184626807
	10,0x2,1x22,23	1	70184626815		
	7,0x2,2x22,23	1		70184626835	
180	10,0x2,2x22,23	1			70184626809
	7,0x2,2x22,23	1	70184626816		
	7,0x2,5x22,23	1		70184626837	
230	10,0x2,2x22,23	1			70184626810
	10,0x2,5x22,23	1	70184626818	70184626838	

**Dimensions Key:** DIA = Diameter, H = Height, T = Thickness, B = Bore

DIAMOND  
TOOLS

CLEANING,  
POLISHING  
& MASKING

PERSONAL  
PROTECTION  
EQUIPMENT

TECHNICAL  
INFORMATION



# DIAMOND BLADES FOR ANGLE GRINDERS

## EXTREME CERAM TURBO

BEST +++++

INNOVATION



For use on granite slabs, ceramic tiles, quarry tiles, porcelain & terazzo.

### FEATURES

- Extra-thin diamond blade
- Additional metal flanges on each side of the blade
- 10mm high continuous rim
- For professional cutting of tiles

### BENEFITS

- Best quality of cut & cutting speed even on the hardest tiles
- Prevents the steel-centre wobbling during the cut
- For longer product life

DIA (mm)	HxTxB (mm)	PK QTY	ART. NO.
115	10,0x1,4x22,23	1	70184644759
125	10,0x1,4x22,23	1	70184644760
230	10,0x1,8x22,23	1	70184621973

## PRO CERAM

BETTER ++++



For use on all ceramic tiles, marble & slate.

### FEATURES

- High-quality diamond blade with excellent performance
- Sintered, continuous rim diamond blade

### BENEFITS

- Long product life combined with an excellent cutting speed

DIA (mm)	HxTxB (mm)	PK QTY	ART. NO.
115	9,0x1,6x22,23	1	70184625942
125	9,0x1,6x22,23	1	70184625940
230	9,0x7,0x22,23	1	70184625946

## CLASSIC CERAM

GOOD +++



Suitable for use on ceramic tiles.

### FEATURES

- Economy diamond blade
- Sintered, continuous rim diamond blade

### BENEFITS

- Value for money

DIA (mm)	HxTxB (mm)	PK QTY	ART. NO.
115	7,0x1,5x22,23	1	70184626825
125	7,0x1,6x22,23	1	70184626826

DIAMOND TOOLS

CLEANING, POLISHING & MASKING

PERSONAL PROTECTION EQUIPMENT

TECHNICAL INFORMATION

# DIAMOND BLADES FOR PETROL HAND HELD & FLOOR SAWS

Norton offers a large range of high performance diamond tools for all applications and user needs.

## APPLICATIONS & MARKETS

- Construction
- Civil Engineering
- Road Contractors



## EXTREME BETON SILENCIO

BEST +++++

INNOVATION



# SILENCIO

For use on cured concrete, reinforced concrete, concrete paving slabs, concrete pipes/kerbs, medium block paviors & concrete roof tiles.

### FEATURES

- Patented offset gullets prevent air from flowing through the steel-centre gullets
- Sandwich steel-centre with newly developed absorbing material
- 15mm high segments, with a bespoke specification for each different application

### BENEFITS

- The blade does not whistle at all while running idle, for a much better comfort of the operator and the surrounding area
- The Norton Clipper Silencio features unprecedented noise-dampening effect, reaching reductions of up to -13dBa - 20 times less noise !!
- The Norton Silencio is among the best cutting Clipper diamond blades. Select the blade specifically designed for your machine type to get the best cutting performance

UP TO  
**20x**  
LESS NOISE

DIA (mm)	HxTxB (mm)	PK QTY	MACHINE	ART. NO.
300	15,0x3,1x20,0	1		70184629000
	15,0x3,1x25,4	1		70184642421
350	15,0x3,1x25,4	1		70184628999
	15,0x3,1x25,4	1		70184628997
450	15,0x3,2x25,4	1		70184631020
500	15,0x3,2x25,4	1		70184630416

**Dimensions Key:** DIA = Diameter, H = Height, T = Thickness, B = Bore

DIAMOND TOOLS

CLEANING, POLISHING & MASKING

PERSONAL PROTECTION EQUIPMENT

TECHNICAL INFORMATION

# DIAMOND BLADES FOR PETROL HAND HELD & FLOOR SAWS

## 4X4 EXPLORER

BETTER ++++



**4  
EXPLORER  
4**



For use on granite, engineering bricks, hard paviers, reinforced concrete, concrete kerbs & slabs, medium block paviers, facing brick, concrete roof tiles, sandstone, asphalt over concrete & asphalt.

### FEATURES

- 12mm high segments with new specification
- Trapezoidal shape segments
- Patented drop-shape gullet
- Smarter diamond blade with segment wear-indicator and cutting depth indicator

### BENEFITS

- Up to 40% faster cut in concrete  
Up to 20% longer life
- Ensure narrowest possible space between each segments for reduces vibrations and better comfort
- Better resistance to cracks for enhanced safety. 4x4 Explorer can cut in metal (up to 5mm thickness).
- Easier mounting, depth control while cutting and better follow up of the product life

DIA (mm)	HxTxB (mm)	PK QTY	MACHINE	ART. NO.
300	12,0x3,0x20	1		70184602022
	12,0x3,0x25,4	1		70184602023
350	12,0x3,2x20	1		70184602091
	12,0x3,2x25,4	1		70184602093
400	12,0x3,2x20	1		70184602094
	12,0x3,2x25,4	1		70184602095
450	12,0x3,2x25,4	1		70184602096

DIAMOND TOOLS

CLEANING, POLISHING & MASKING

PERSONAL PROTECTION EQUIPMENT

TECHNICAL INFORMATION

## PRO ASPHALT



For use on all abrasive materials including asphalt, tarmac top blocks, breeze blocks, sandstone, mortar jointing & green concrete.

### FEATURES

- Features the innovative patented "depth of cut indicator"
- High-quality diamond blade for professional requirements
- Laser-welded diamond blade with 10mm segment height

### BENEFITS

- The perfect device to optimise cutting speed & blade life in step-cutting. It also shows the way of rotation for an easier mounting of the diamond blade
- Slant segments protect against undercutting giving excellent performance

DIA (mm)	HxTxB (mm)	PK QTY	ART. NO.
300	10,0x2,8x25,4	1	70184623184
350	10,0x3,2x25,4	1	70184623186

## QUICKFIX REDUCTION RINGS



For use only with petrol saws

### FEATURES

- Converts 300mm & 350mm x 25,4mm or 22,23mm bore to 20mm
- A patented device designed to safely convert blade bores to suit different machines

### BENEFITS

- Can reduce inventory

DIA (mm)	BORE (mm)	PK QTY	ART. NO.
103	25,4/22,23	1	70184622589
	25,4/22,23/20	1	70184623894

**Dimensions Key:** DIA = Diameter, H = Height, T = Thickness, B = Bore

# DIAMOND BLADES FOR MASONRY SAWS

Norton offers the best range of diamond tools for masonry saws ensuring great performance and clean results in wet cutting conditions.

## APPLICATIONS & MARKETS

- Construction



## EXTREME UNIVERSAL SILENCIO

BEST +++++

INNOVATION



## SILENCIO

For use on engineering bricks, cured concrete, reinforced concrete, hard paviors, concrete paving slabs, concrete kerbs, concrete pipes, limestone, medium block paviors, facing bricks.

### FEATURES

- Patented offset gullets prevent air from flowing through the steel-centre gullets
- Sandwich steel-centre with newly developed absorbing material
- 15mm high segments, with a bespoke specification for each different application

### BENEFITS

- The blade does not whistle at all while running idle, provides improved comfort for the operator and the surrounding area
- The Norton Clipper Silencio features unprecedented noise-dampening effect, reaching reductions of up to 15dB – 30 times less noise !!
- The Norton Silencio is among the best cutting Clipper diamond blades. Select the blade specifically designed for your machine type to get the best cutting performance

UP TO  
**30x**  
LESS NOISE

DIA (mm)	HxTxB (mm)	PK QTY	ART. NO.
300	15,0x3,1x25,4	1	70184640269
350	15,0x3,1x25,4	1	70184628998
400	15,0x3,1x25,4	1	70184640270
500	15,0x3,2x25,4	1	70184630309

DIAMOND TOOLS

CLEANING, POLISHING & MASKING

PERSONAL PROTECTION EQUIPMENT

TECHNICAL INFORMATION



## EXTREME UNIVERSAL LASER

BEST +++++



For use on general purpose masonry materials, granite, concrete slabs, reinforced concrete, hard paviers, hard facing bricks, concrete roof tiles.

### FEATURES

- 15mm segment height
- High quality diamond blade
- Trapezoidal segments
- Laser-welded diamond blade

### BENEFITS

- Long product life
- Extremely high cutting speed
- Provides the quality of cut of a continuous rim with the safety of a laser-welded blade

DIA (mm)	HxTxB (mm)	PK QTY	ART. NO.
300	15,0x2,8x30/25,4	1	70184612282
350	15,0x2,8x30/25,4	1	70184612283
400	10,0x3,2x25,4	1	70184611438

## 4X4 EXPLORER

BETTER ++++



**4  
EXPLORER  
4**



For use on granite, engineering bricks, hard paviers, reinforced concrete, concrete kerbs & slabs, medium block paviers, facing brick, concrete roof tiles, sandstone, asphalt over concrete & asphalt.

### FEATURES

- 12mm high segments with new specification
- Trapezoidal shape segments
- Patented drop-shape gullet
- Smarter diamond blade with segment wear-indicator and cutting depth indicator

### BENEFITS

- Up to 40% faster cut in concrete  
Up to 20% longer life
- Ensure narrowest possible space between each segments for reduced vibrations and better comfort
- Better resistance to cracks for enhanced safety. 4x4 Explorer can cut in metal (up to 5mm thickness).
- Easier mounting, depth control while cutting and better follow up of the product life

DIA (mm)	HxTxB (mm)	PK QTY	ART. NO.
300	12,0x3,0x25,4	1	70184602023
350	12,0x3,2x25,4	1	70184602093
400	12,0x3,2x25,4	1	70184602095
450	12,0x3,2x25,4	1	70184602096

**Dimensions Key:** DIA = Diameter, H = Height, T = Thickness, B = Bore



# DIAMOND BLADES FOR MASONRY SAWS

## PRO UNIVERSAL LASER



For use on general purpose masonry materials, breeze blocks, concrete paving slabs & concrete pipes/kerbs.

### FEATURES

- Laser-welded, segmented diamond blade

### BENEFITS

- Ideal for abrasive to medium hard material

DIA (mm)	HxTxB (mm)	PK QTY	ART. NO.
650	12,0x4,4x25,4	1	70184647265
900	12,0x4,4x60/55	1	70184647266

## PRO UNIVERSAL LASER



For use on general purpose masonry materials.

### FEATURES

- Laser-welded diamond blade
- Good performance

### BENEFITS

- Ideal for abrasive to medium hard material
- Good product life & high cutting speed

DIA (mm)	HxTxB (mm)	PK QTY	ART. NO.
350	10,0x2,8x25,4	1	70184611209



## EXTREME CERAM TURBO

BEST +++++



For use on the granite slabs, ceramic tiles, quarry tiles, porcelain, terrazzo.

### FEATURES

- Extra-thin diamond blade
- Additional metal flanges
- 10mm continuous rim

### BENEFITS

- For professional cutting of tiles
- The best quality of cut & cutting speed even on the hardest tiles
- Prevent wobbling of the steel-centre during the cut
- Longer product life

DIA (mm)	HxTxB (mm)	PK QTY	ART. NO.
300	10,0x1,8x25,4	1	70184625429

## PRO CERAM

BETTER ++++



For use on ceramic tiles, stone tiles, marble granite, terrazzo & limestone.

### FEATURES

- Sintered, continuous rim diamond blade
- 9mm segment height
- Heavy duty diamond blade

### BENEFITS

- Excellent cutting speed, producing a very clean cut
- Long life
- Ideal for glazed materials

DIA (mm)	HxTxB (mm)	PK QTY	ART. NO.
300	9,5x2,0x25,4	1	70184625098
350	9,5x2,0x25,4	1	70184625100

**Dimensions Key:** DIA = Diameter, H = Height, T = Thickness, B = Bore

# DIAMOND BLADES FOR TILE SAWS

Norton tile saw blades come in a range of sizes designed to all common tile saw machines.

## APPLICATIONS & MARKETS

- Construction
- Tiling
- Bathroom fitting
- Kitchen fitting



## EXTREME CERAM TURBO

BEST +++++



For use on the granite slabs, ceramic tiles, quarry tiles, porcelain, terrazzo.

### FEATURES

- Extra-thin diamond blade
- Additional metal flanges
- 10mm continuous rim

### BENEFITS

- For professional cutting of tiles
- The best quality of cut & cutting speed even on the hardest tiles
- Prevent wobbling of the steel-centre during the cut
- Longer product life

DIA (mm)	HxTxB (mm)	PK QTY	ART. NO.
200	10,0x1,6x25,4	1	70184625427
250	10,0x1,6x25,4	1	70184625428

DIAMOND TOOLS

CLEANING, POLISHING & MASKING

PERSONAL PROTECTION EQUIPMENT

TECHNICAL INFORMATION

## PRO CERAM

BETTER ++++



For use on ceramic tiles, stone tiles, marble granite, terrazzo & limestone.

### FEATURES

- Sintered, continuous rim diamond blade
- 9mm segment height
- Heavy duty diamond blade

### BENEFITS

- Excellent cutting speed, producing a very clean cut
- Long life
- Ideal for glazed materials

DIA (mm)	HxTxB (mm)	PK QTY	ART. NO.
180	9,0x1,6x25,4	1	70184625561
200	9,0x1,6x25,4	1	70184625093
230	9,0x1,6x25,4	1	70184625096
250	9,0x1,6x25,4	1	70184625097

## CLASSIC CERAM

GOOD +++



For use on ceramic tiles.

### FEATURES

- Economy range
- Sintered, continuous rim diamond blade

### BENEFITS

- Value for money

DIA (mm)	HxTxB (mm)	PK QTY	ART. NO.
180	7,0x1,7x25,4	1	70184626828
200	7,0x1,7x25,4	1	70184626829
230	7,0x1,8x25,4	1	70184626830

**Dimensions Key:** DIA = Diameter, H = Height, T = Thickness, B = Bore

# CORE BITS FOR CONCRETE & REINFORCED CONCRETE (DRILL RIGS)

Norton core bits are extremely high performance products, providing an extremely good cutting speed and long product life. The products meet the professional requirements of all users in industrial markets, including builders, electricians and plumbers. They are recommended for use on motors up to 3300W.

## APPLICATIONS & MARKETS

- For installation of electrical wall sockets & switches
- For use on cured concrete, reinforced concrete & bricks



## PRO CB BETON CROWNED

BETTER ++++



Crowned corebit for use on cured concrete & bricks.

### FEATURES

- Excellent performance for professional requirements
- Back end R1/2" male
- Length 300mm
- Recommended for engines up to 2000W

### BENEFITS

- Excellent cutting speed and long product life

DIA (mm)	Useful Length (mm)	Segment Height (mm)	PK QTY	ART. NO.
14	300	10	1	70184612947
18	300	10	1	70184612824
22	300	10	1	70184612826
25	300	10	1	70184612827
28	300	10	1	70184612828
30	300	10	1	70184612829
32	300	10	1	70184612830
35	300	10	1	70184612831
40	300	10	1	70184612834
51	300	10	1	70184612835

DIAMOND TOOLS

CLEANING, POLISHING & MASKING

PERSONAL PROTECTION EQUIPMENT

TECHNICAL INFORMATION

## PRO CB BETON SEGMENTED



Laser-welded segmented corebit for use on cured concrete, reinforced concrete & bricks.

### FEATURES

- Laser-welded heavy-duty corebit
- Tapered segment shape
- Back end 1 1/4" UNC
- Length 450mm

### BENEFITS

- Excellent cutting speed
- Easier drilling start

DIA (mm)	Useful Length (mm)	Segment Height (mm)	PK QTY	ART. NO.
52	450	10	1	70184624870
62	450	10	1	70184624872
72	450	10	1	70184624874
82	450	10	1	70184624876
102	450	10	1	70184624880
107	450	10	1	70184624881
112	450	10	1	70184624882
122	450	10	1	70184624883
127	450	10	1	70184624884
132	450	10	1	70184624885
152	450	10	1	70184624887
162	450	10	1	70184624888
182	450	10	1	70184624890
202	450	10	1	70184624892
252	450	10	1	70184624895
300	450	10	1	70184624897

**Dimensions Key:** DIA = Diameter



# CORE BITS FOR CONCRETE & REINFORCED CONCRETE (DRILL RIGS)

## CLASSIC CB BETON

GOOD +++



Laser-welded segmented corebit for use on reinforced concrete, cured concrete & normal aggregates.

### FEATURES

- Good quality product
- Back end 1 1/4" UNC
- Length 450mm

### BENEFITS

- Good cutting speed

DIA (mm)	Useful Length (mm)	Segment Height (mm)	PK QTY	ART. NO.
51	450	10	1	70184613201
56	450	10	1	70184613202
61	450	10	1	70184613203
66	450	10	1	70184613204
71	450	10	1	70184613205
76	450	10	1	70184613206
81	450	10	1	70184613207
86	450	10	1	70184613208
91	450	10	1	70184613209
101	450	10	1	70184613210
106	450	10	1	70184613211
111	450	10	1	70184613212
121	450	10	1	70184613213
126	450	10	1	70184613214
131	450	10	1	70184613215
141	450	10	1	70184613216
151	450	10	1	70184613217
161	450	10	1	70184613218
171	450	10	1	70184613219
181	450	10	1	70184613220
191	450	10	1	70184613221*
201	450	10	1	70184613222
211	450	10	1	70184613223
225	450	10	1	70184613252
251	450	10	1	70184613224
271	450	10	1	70184613253
300	450	10	1	70184613225

\* Made-to-order

Dimensions Key: DIA = Diameter

DIAMOND TOOLS

CLEANING, POLISHING & MASKING

PERSONAL PROTECTION EQUIPMENT

TECHNICAL INFORMATION

# CORE BITS FOR CONCRETE & MASONRY (HAND DRILLS)

## EXTREME CB UNIVERSAL

BEST +++++



Laser-welded dry-drilling corebits with M16 connection.

### FEATURES

- New swirled core
- Laser-welded core bit
- Useful length 150mm, connection M16 female thread

### BENEFITS

- Reduced frictions and better dust evacuation
- High speed & long product life

## PRO CB UNIVERSAL

BETTER ++++



Newly developed specification for improved productivity on the jobsite.

### FEATURES

- Braced segmented corebit
- Heavy duty diamond tool
- Connection R1/2" female

### BENEFITS

- Long life, ideal for craftsmen
- Excellent cutting speed
- Useful length 150mm

# CORE BITS FOR CONCRETE & MASONRY (HAND DRILLS)

## CLASSIC CB UNIVERSAL

GOOD +++



Affordable corebits for professional craftsmen.

### FEATURES

- Heavy welded segmented core bit
- Connection R1/2" female

### BENEFITS

- Long life

## CLASSIC DS



Suitable for drilling domestic & industrial installation of electrical wall sockets & switches.

### FEATURES

- Laser-welded segments
- Heavy diamond tool
- For dry & wet drilling
- Useful length
- Connection M16

### BENEFITS

- Extremely long life
- Excellent cutting speed



## CORE BITS - DRY



DIA (mm)	Useful Length (mm)	Segment Height (mm)	PK QTY	EXTREME CB UNI	PRO CB UNI	CLASSIC CB UNI	CLASSIC DS
				BEST	BETTER	GOOD	
28	300	7	1			70184620351	
38	150	7	1		70184640160	70184620352	
48	150	7	1		70184694047		
52	150	7	1	70184601792	70184640161	70184620353	
65	150	7	1	70184601793	70184640162	70184640268	
68	60	7	1				70184620422
78	150	7	1		70184640163	70184620354	
82	60	7	1				70184620423
	150	7	1	70184601794			
91	150	7	1	70184601874	70184694048		
102	150	7	1	70184601795			
107	150	7	1	70184601796	70184640164	70184620355	
117	150	7	1	70184601797	70184640165	70184620356	
127	150	7	1	70184601798	70184640166	70184620357	
152	150	7	1	70184601799	70184640167	70184620358	
162	150	7	1	70184601800			
202	150	7	1	70184601875			

Dimensions Key: DIA = Diameter

DIAMOND TOOLS

CLEANING, POLISHING & MASKING

PERSONAL PROTECTION EQUIPMENT

TECHNICAL INFORMATION

# 463-512

## CLEANING, POLISHING & MASKING



464 Introduction  
469 Wire Brushes for  
Bench Grinders  
471 Wire Brushes for  
Angle Grinders

477 Wire Brushes for  
Hand Drills  
480 Hand Wire Brushes  
484 Tungsten Carbide Burrs

497 Steel Wool  
498 Cleaning & Polishing  
Products  
504 Masking Tapes

CLEANING,  
POLISHING  
& MASKING

PERSONAL  
PROTECTION  
EQUIPMENT

TECHNICAL  
INFORMATION

# INTRODUCTION







Norton offers a broad range of wire brushes suitable for a wide range of surface processing applications. The range encompasses crimped & knotted wire power wheel brushes, bevelled brushes, cup brushes, end brushes & hand brushes.

Our high quality products contain a number different types of wire which have been specifically selected to give the best results in any specific application.

## WIRE TYPES

TEMPERED QUALITY STEEL WIRE			STAINLESS STEEL WIRE			BRASS WIRE
CRIMPED	STRAIGHT		CRIMPED	STRAIGHT		CRIMPED
						
Removing dust and smoothing low-grade and non alloy steels			Brushing and smoothing chrome-nickel steels, including stainless steel			Brushing, cleaning and smoothing brass, copper and bronze
NOSCW NOrmal Steel Crimped Wire	NOSKW NOrmal Steel Knotted Wire	NOSSW NOrmal Steel Straight Wire	STSCW STainless Steel Crimped Wire	STSKW STainless Steel Knotted Wire	STSSW STainless Steel Straight Wire	BRACW BRAss Crimped Wire

## SHAPE KEY

CODE	PRODUCT TYPE	TOOL	APPLICATION
WHB	Crimped Wheel Brushes		Supplied as standard with arbour hole as indicated. The size of the arbour hole can be reduced with reduction rings. Wheel brushes with short wire are more aggressive. Larger widths require more horse power.
	Twist Knotted Wheel Brushes		This brush is ideally suited for brushing out welded joints and brushing sharp corners.
BEB	Bevel Brushes		Specially designed for brushing hard-to-reach places such as edges and corners.
CPB	Crimped Cup Brushes		This brush is designed for cleaning jobs, especially on larger surfaces. It is ideal for removing rust, corrosion, paint & primers. Removal of rust, corrosion, paint and primers.
	Twist Knotted Cup Brushes		An aggressive brush which is excellent for heavy-duty cleaning and finishing of large surfaces. Extremely suitable for removing barnacles, scale, paint, rust and corrosion, as well as cleaning weld seams and spot-welds.
WHB/ENB	Shaft Mounted Brushes		Suitable for industrial use. Ideal for hard-to-reach areas. All shaft mounted brushes are equipped with a 6mm shank.
HCB/SPB	Hand Brushes		With wooden core. Available in different widths. For use on narrow work pieces. Ideal for light deburring & cleaning profiled surfaces
TUB	Pipe Brushes		With handle or thread. For deburring and cleaning tubes.

## OPERATING SPEED

Peripheral speed is a decisive factor in achieving optimum performance from a brush, the table opposite enables you to determine the relevant peripheral speed by simply reading down and across the appropriate diameter and drive shaft operating speed columns.

RPM	BRUSH DIAMETER (mm)											
	20	40	50	80	100	125	150	180	200	250	300	350
min <sup>-1</sup>												
800				3,35	4,19	5,23	6,28	7,53	8,37	10,47	12,56	14,75
900			2,35	3,77	4,71	5,88	7,06	8,48	9,41	11,77	14,12	16,47
1150			3,01	4,81	6,01	7,52	9,02	10,83	12,03	15,04	18,04	21,04
1200	1,26	2,51	3,14	5,02	6,28	7,85	9,41	11,3	12,55	15,69	18,83	21,97
1400	1,46	2,93	3,66	5,86	7,32	9,15	10,98	13,18	14,64	18,31	21,97	25,63
1500	1,57	3,14	3,92	6,28	7,85	9,81	11,77	14,13	15,69	19,61	23,54	27,46
1800	1,88	3,77	4,71	7,54	9,41	11,77	14,12	16,95	18,83	23,54	28,24	32,95
2000	2,09	4,19	5,23	8,37	10,26	13,08	15,69	18,84	20,92	26,15	31,38	36,61
2500	2,62	5,23	6,54	10,47	13,08	16,35	19,61	23,55	26,15	32,67	39,23	45,76
2800	2,93	5,86	7,32	11,72	14,64	18,31	21,97	26,37	29,29	36,61	43,93	51,25
3000	3,14	6,28	7,85	12,56	15,69	19,62	23,54	28,26	31,38	39,23	47,07	54,92
3200	3,35	6,7	8,37	13,4	16,74	20,92	25,1	30,14	33,47	41,84	50,21	58,58
3500	3,66	7,33	9,15	14,65	18,31	22,89	27,46	32,97	36,61	45,76	54,92	64,07
4000	4,19	8,37	10,46	16,75	20,92	26,16	31,38	37,68	41,84	52,33	62,76	73,22
4500	4,7	9,42	11,77	18,84	23,54	29,43	35,3	42,4	47,07	58,84	70,61	82,43
5000	5,23	10,47	13,08	20,93	26,15	32,7	39,23	47,1	52,33	65,38	78,5	
5400	5,65	11,3	14,12	22,94	28,24	35,31	42,36	50,67	56,48	70,61	84,78	
6000	6,28	12,56	15,69	25,12	31,38	39,24	47,07	56,52	62,76	78,5		
7000	7,33	14,66	18,31	29,31	36,61	45,78	54,92	65,94	73,22	91,58		
8000	8,37	16,75	20,92	33,94	41,48	52,32	62,76	75,36	83,73			
9000	9,42	18,84	23,54	37,68	47,07	58,86	70,61	84,78	94,2			
10000	10,47	20,93	26,17	41,86	52,33	65,4	78,5	94,2				
12500	13,08	26,17	32,71	52,33	65,42	81,75	98,13					
15000	15,7	31,4	39,25	62,8								
17500	18,32	36,63	45,79	73,26								
20000	20,93	41,87	52,33	83,73								
22500	23,55	47,1	58,88	94,2								
25000	26,17	52,33	65,42	104,66								

### HOW TO READ THIS TABLE?

Select your brush diameter, then move down till you reach desirable peripheral speed in m/s, after check on the left side of the table the value for the RPM. Check on page 466 the maximum operating speed per type of brush.



## MAXIMUM OPERATING SPEED

TYPE	DIAMETER (mm)	MAX RPM	TYPE	DIAMETER (mm)	MAX RPM	
 WHEEL BRUSHES	80	10000	 BEVEL BRUSHES	100	11000	
	100	8000		100/115	11000	
	125	6000		115	10000	
	 CUP BRUSHES	150	6000	 TWIST KNOTTED WHEEL BRUSHES	100	11000
		180	6000		115	11000
		200	4500		125	10000
		250	3600		150/180	8500
		250 - 1 row	3500		200	6500
		300	3000	 SHAFT MOUNTED WIRE BRUSHES	20	20000
60/65/75		11000	30		20000	
60/65/75		11000	40		18000	
75	9300	50	15000			
80/100	8500	60	15000			
125/150	6500	70	15000			
			80	12000		

The maximum RPM ratings are safety ratings not recommended operating speeds. The optimum operating speed is determined by the application and in most cases lower operating speeds will prove more efficient and achieve the best result. As a general guide we recommend the following peripheral speeds when working on the materials listed with:

APPLICATION	CRIMPED WIRE	TWIST KNOTTED
STEEL	30m/s	35-40m/s
NON FERROUS	18-20m/s	
PLASTIC	15m/s	

### BRUSHING PRESSURE

- Let the tip of the wire brush do the work. Operate the brush with the lightest pressure so only the tips of the wire come in contact with the work
- If heavy pressure is used, wires will be over stressed, resulting in a wiping action, and if this is continued, the life of the brush will be shortened due to wire fatigue
- Apply the work to the face of the brush ensuring as much of the brush face as possible is in full contact. Applying the work to the side or edge of the brushing tool will result in wire breakage and shortened brush life
- Reversing the wheel brush rotation periodically will tend to increase the life of the brush. This results in the sharpening of the wire tips or ends, ensuring faster cutting action

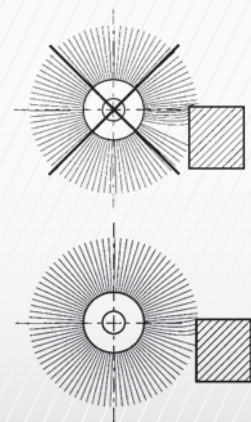

### SIZE OF WIRE

- Use the finest size of wire suitable for the application
- Finer wire size will perform better and last longer than heavier

## TROUBLESHOOTING

Several factors can influence a brush application. If the selected brush does not achieve the expected result, the following table may provide solutions for the most common problems faced by a user. For further information, please contact our technical department.

PROBLEM	RECOMMENDED ACTIONS
Brush is too aggressive	Increase trim length
	Reduce wire diameter
	Reduce operating speed
Brush is not aggressive enough	Reduce trim length
	Increase wire diameter
	Increase operating speed
Action of brush does not totally remove scale	Reduce trim length
	Increase wire diameter
Finish is too coarse	Increase trim length
	Reduce wire diameter
	Increase operating speed
	Choose a nylon abrasive brush
Finish is too smooth	Reduce trim length
	Increase wire diameter
Action of brush is not uniform	Reduce brushing pressure
	Automate operations to avoid human inaccuracy
Wire breaks more than usual	Reduce brushing pressure
	Reduce wire diameter
	Reduce operating speed
Life of the brush is too short	Reduce wire diameter
	Increase brush diameter
	Reduce brushing pressure

### SAFETY & STORAGE

Safety goggles or full face protection with side shields must be worn by all operators and others in the immediate area of power brush operations.

- Keep all machine guards in place
- Observe all speed restrictions indicated on brushes
- Appropriate protective clothing and equipment must be used
- Brushes should be carefully checked when removed from the original carton. Do not use if rusted or damaged
- Store brushes in the original carton. Wire brushes should not be exposed to heat, high humidity, acids, fumes or liquids that can result in deterioration of the wire filaments, and subsequently, premature failure of the wires. Also, check for distortion of brush fill that can cause imbalance and excessive vibration when the brush is running
- Check maximum spindle speed. Do not mount and operate the brush if spindle RPM exceeds the maximum safe free speed for which the brush is rated. Spindle length should be sufficient to permit a full nut mounting
- Before starting the machine, rotate the wire brush with a gloved hand to determine that the brush has been correctly mounted and turns freely

# FLANGES

## METAL REDUCING FLANGES FOR WHEEL BRUSHES

SIZE (mm) ODxID	PK QTY	ART. NO.
20x13	1	66254406503*
20x16	1	66254406501*
30x13	1	66254406500*
30x16	1	66254406487*
30x20	1	66254406486*
30x25,4	1	66254406484*
50,8x30	1	66254406482*
50,8x32	1	66254406481*
80x30	1	66254406478*
80x32	1	66254406476*
80x50,8	1	66254406472*
100x30	1	66254406468*
100x32	1	66254406467*
100x50,8	1	66254406457*
120x30	1	63642589202*
120x32	1	63642589203*
120x50,8	1	63642589204*

\* Made-to-order

# WIRE BRUSHES FOR BENCH GRINDERS

## FEATURES

- Wheel brushes are ideal for removing corrosion, rust, hardened paints & hard adhesive residues
- Twist Knotted Wire is ideal for heavier applications
- Crimped Wire is ideal for lighter applications

## BENEFITS

- Can be used universally on all kinds of applications (tubes, corners, angles)
- Good surface finish, especially smaller diameter wheels
- Good price/performance ratio



## WHEEL BRUSHES (WHB)



### NORMAL STEEL CRIMPED WIRE (NOSCW) - 1 ROW

SHAPE	D	B	A	R	WIRE Ø	ROW	L	PK QTY	ART. NO.
WHB	100	11	12	20	0,30	1R	T22	1	66254406455*
	125	11	12	20	0,30	1R	T34	1	66254406454
	150	13	12	32	0,30	1R	T34	1	66254406453*
	180	13	12	50,8	0,30	1R	T33	1	66254406452*
	200	13	12	50,8	0,30	1R	T43	1	66254406451



\* Made-to-order

**Dimensions Key:** D = Diameter, B = Width, A = Bore min, R = Bore max, L = Wire Length, OD = Outer Diameter, ID = Inner Diameter

### SHAPE KEY

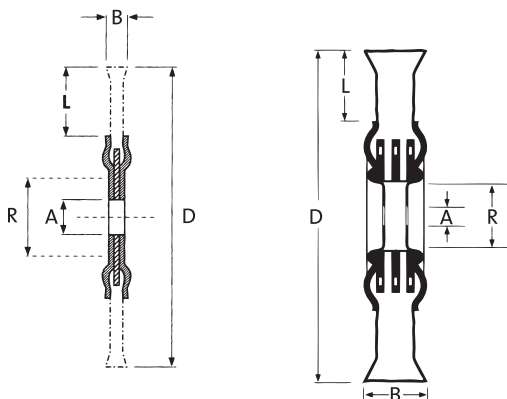

# WIRE BRUSHES FOR BENCH GRINDERS

## WHEEL BRUSHES (WHB)



### NORMAL STEEL CRIMPED WIRE (NOSCW) - 2/3 ROWS

SHAPE	D	B	A	R	WIRE Ø	ROW	L	PK QTY	ART. NO.
WHB	100	20	20	30	0,20	2R	T24	1	66254406450
	125	24	20	30	0,20	2R	T36	1	66254406409
	150	29	32	51	0,20	2R	T27	1	66254406407
	180	22	32	51	0,20	2R	T42	1	66254406403*
	200	26	32	80	0,20	2R	T40	1	66254406401
	80	15	20	20	0,30	2R	T20	1	66254406399
	100	20	20	30	0,30	2R	T24	1	66254406284
	100	28	20	30	0,30	3R	T24	1	66254406283*
	125	24	20	30	0,30	2R	T36	1	66254406282
	150	18	32	51	0,30	2R	T27	1	66254406265
	150	29	32	51	0,30	2R	T27	1	66254406264
	180	22	32	51	0,30	2R	T42	1	66254406263
	180	28	32	51	0,30	2R	T42	1	66254406259
	200	26	32	80	0,30	2R	T40	1	66254406255
	200	36	32	80	0,30	3R	T40	1	66254406243
	250	32	50,8	100	0,30	2R	T50	1	66254406241
	300	32	50,8	100	0,30	2R	T60	1	66254406240*
	150	29	32	51	0,50	2R	T27	1	66254406239*
	180	28	32	51	0,50	3R	T42	1	66254406237*
	200	26	32	80	0,50	2R	T40	1	66254406216
250	38	50,8	100	0,50	3R	T50	1	66254406214	

### STAINLESS STEEL CRIMPED WIRE (STSCW)

WHB	150	18	32	51	0,20	2R	T27	1	66254406211*
	125	24	20	30	0,30	2R	T36	1	66254406208*
	150	18	32	51	0,30	2R	T27	1	66254406206
	150	29	32	51	0,30	3R	T27	1	66254406203
	180	22	32	51	0,30	2R	T42	1	66254406199*
	180	28	32	51	0,30	3R	T42	1	66254406196
	200	26	32	80	0,30	2R	T40	1	66254406187

### BRASS CRIMPED WIRE (BRACW)

WHB	150	29	32	51	0,20	3R	T43	1	66254414433*
-----	-----	----	----	----	------	----	-----	---	--------------

\* Made-to-order

CLEANING,  
POLISHING  
& MASKING

PERSONAL  
PROTECTION  
EQUIPMENT

TECHNICAL  
INFORMATION



# WIRE BRUSHES FOR ANGLE GRINDERS

## FEATURES

- Larger diameter brushes for heavier applications
- Smaller diameters brushes for finer applications
- Twist Knotted Wire is ideal for pipes

## BENEFITS

- Excellent performance for deburring, removing rust, paint & corrosion and weld scale spatter
- Almost spark free and lower thermal impact
- Good price/performance ratio
- Uniform brushing, even in difficult-to-reach areas



## WHEEL BRUSHES (WHB)



### NORMAL STEEL TWIST KNOTTED WIRE (NOSKW)

SHAPE	D	B	A	WIRE Ø	L	PK QTY	ART. NO.
WHB	100	11	22,2	0,35	T22	1	66254406185
	115	11	22,2	0,35	T23	1	66254406180*
	125	13	22,2	0,35	T28	1	66254406178
	178	15	22,2	0,35	T35	1	66254406175*
	115	11	M14	0,35	T23	1	66254406173
	125	13	M14	0,35	T28	1	66254406172
	100	11	22,2	0,50	T22	1	66254406170*
	115	11	22,2	0,50	T23	1	66254406167
	125	13	22,2	0,50	T28	1	66254406166
	150	12	22,2	0,50	T34	1	66254406164
	178	15	22,2	0,50	T35	1	66254406163
	115	11	M14	0,50	T23	1	66254406160
	125	13	M14	0,50	T28	1	66254406158
	178	15	M14	0,50	T44	1	66254406155



SHAPE KEY

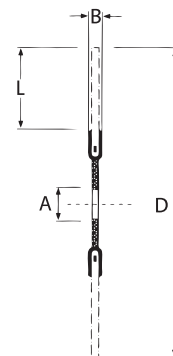

### STAINLESS STEEL TWIST KNOTTED WIRE (STSKW)

WHB	115	11	22,2	0,50	T23	1	66254406153
	125	11	22,2	0,50	T23	1	66254410928*

\* Made-to-order

All sizes also available with left hand twist knot direction upon request.

**Dimensions Key:** D = Diameter, B = Width, A = Bore min, R = Bore max, L = Wire Length



# WIRE BRUSHES FOR ANGLE GRINDERS

## WHEEL BRUSHES (WHB)



### NORMAL STEEL TWIST KNOTTED WIRE (NOSKW) HIGH PERFORMANCE RANGE



SHAPE	D	B	A	WIRE Ø	L	NUMBER OF KNOT	PK QTY	ART. NO.
WHB	115	6	22,2	0,50	10	36	1	63642581151
	125	6	22,2	0,50	15	42	1	63642581157
	150	6	22,2	0,50	15	56	1	63642581162
	165	6	22,2	0,50	15	56	1	63642581167
	178	6	22,2	0,50	15	76	1	63642581169

### STAINLESS STEEL TWIST KNOTTED WIRE (STSKW) HIGH PERFORMANCE RANGE



SHAPE	D	B	A	WIRE Ø	L	NUMBER OF KNOT	PK QTY	ART. NO.
WHB	115	6	22,2	0,50	10	36	1	63642581639
	125	6	22,2	0,50	15	42	1	63642581640
	150	6	22,2	0,50	15	56	1	63642581644
	165	6	22,2	0,50	15	56	1	63642581645
	178	6	22,2	0,50	15	76	1	63642581646

## BEVEL BRUSHES (BEB)



### NORMAL STEEL TWIST KNOTTED WIRE (NOSKW)



SHAPE	D	B	A	WIRE Ø	L	PK QTY	ART. NO.
BEB	100	13	M14	0,50	T20	1	66254406149
	115	15	M14	0,50	T27,5	1	66254406147

### STAINLESS STEEL TWIST KNOTTED WIRE (STSKW)

SHAPE KEY

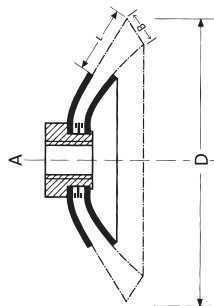

SHAPE	D	B	A	WIRE Ø	L	PK QTY	ART. NO.
BEB	100	10	M14	0,50	T20	1	66254406146
	115	15	M14	0,50	T27,5	1	66254406144

### NORMAL STEEL CRIMPED WIRE (NOSCW)

SHAPE	D	B	A	WIRE Ø	L	PK QTY	ART. NO.
BEB	100	13	M14	0,30	T20	1	66254406142
	115	15	M14	0,30	T20	1	66254406109*

Bevel brushes supplied with left-hand knots.  
Right-hand knots available upon request.

\* Made-to-order



## BEVEL BRUSHES (BEB) WITH SAFETY GUARD



Specially designed for brushing hard-to-reach places such as edges and corners, offering higher:

- **PROTECTION AND VISIBILITY**  
The guard acts as a shield that prevents wire, dust and any other kind of projections from reaching the user during work.
- **FLEXIBILITY**  
The adaptability of the material of the guard makes the brush suitable for work not only on open surfaces but also on difficult areas.



### NORMAL STEEL CRIMPED WIRE (NOSCW)

SHAPE	D	A	WIRE Ø	L	PK QTY	ART. NO.
BEB	100	M14	0,30	T24	12	66261103056

### STAINLESS STEEL CRIMPED WIRE (STSCW)

SHAPE	D	A	WIRE Ø	L	PK QTY	ART. NO.
BEB	100	M14	0,30	T24	12	66261103180

**Dimensions Key:** D = Diameter, B = Width, A = Bore min, L = Wire Length

SHAPE KEY

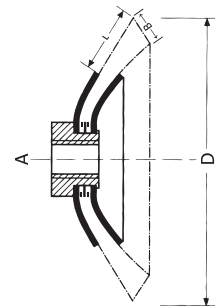

# WIRE BRUSHES FOR ANGLE GRINDERS

## CUP BRUSHES (CPB)



### NORMAL STEEL TWIST KNOTTED WIRE (NOSKW)



SHAPE KEY

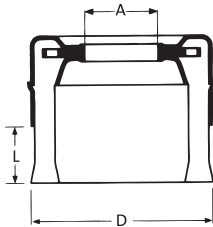

SHAPE	D	A	WIRE Ø	L	PK QTY	ART. NO.
CPB	65	M10	0,35	T20	1	66254406107
	65	M14	0,35	T20	1	66254406104
	80	M14	0,35	T25	1	66254406102
	100	M14	0,35	T25	1	66254406099
	120	M14	0,35	T25	1	66254406097*
	65	M14	0,50	T20	1	66254406095
	80	M14	0,50	T25	1	66254406094
	80	5/8"	0,50	T25	1	66254406091*
	100	M14	0,50	T25	1	66254406088
	100	5/8"	0,50	T25	1	66254406086*
	120	M14	0,50	T25	1	66254406084*
	80	M14	0,80	T25	1	66254406082*
	80	5/8"	0,80	T25	1	66254406079*
	100	M14	0,80	T25	1	66254406076*
	120	M14	0,80	T25	1	66254406070*

## CUP BRUSHES (CPB)



### STAINLESS STEEL TWIST KNOTTED WIRE (STSKW)

SHAPE	D	A	WIRE Ø	L	PK QTY	ART. NO.
CPB	65	M14	0,50	T20	1	66254406068
	80	M14	0,50	T25	1	66254406067
	100	M14	0,50	T25	1	66254406065*



### NORMAL STEEL CRIMPED WIRE (NOSCW)

CPB	60	M14	0,20	T16	1	66254406062
	75	M14	0,20	T20	1	66254406059
	60	M14	0,30	T16	1	66254406058
	75	M14	0,30	T20	1	66254406055
	80	M14	0,30	T25	1	66254406054
	100	M14	0,30	T30	1	66254406053
	125	22,2	0,30	T35	1	66254406052
	125	M14	0,30	T35	1	66254406050
	150	M14	0,30	T55	1	66254406049
	80	M14	0,50	T25	1	66254406048*



SHAPE KEY

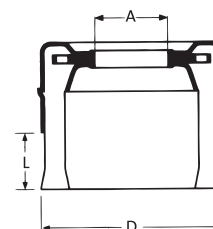

### STAINLESS STEEL CRIMPED WIRE (STSCW)

CPB	60	M14	0,30	T16	1	66254406037
	80	M14	0,30	T25	1	66254404868

\* Made-to-order

**Dimensions Key:** D = Diameter, A = Bore min, L = Wire Length

# WIRE BRUSHES FOR ANGLE GRINDERS

## CUP BRUSHES (CPB) WITH SAFETY GUARD



### TWIST KNOTTED WIRE

Aggressive model for high speed brushing in metalwork such as roughening, removing rust, paint & corrosion and weld scale spatter. Ideal product for brushing larger surfaces offering higher:

- PROTECTION AND VISIBILITY  
The guard acts as a shield that prevents wire, dust and any other kind of projections from reaching the user during work.
- FLEXIBILITY  
The adaptability of the material of the guard makes the brush suitable for work not only on open surfaces but also on difficult areas.

### NORMAL STEEL TWIST KNOTTED WIRE (NOSKW)

SHAPE	D	A	WIRE Ø	L	PK QTY	ART. NO.
CPB	65	M14	0,50	T20	12	66261103046

### STAINLESS STEEL TWIST KNOTTED WIRE (STSKW)

SHAPE	D	A	WIRE Ø	L	PK QTY	ART. NO.
CPB	65	M14	0,50	T20	12	66261103171



### CRIMPED WIRE

Multi-purpose model for cleaning jobs, especially on larger surfaces. It is ideal for removing rust, corrosion, paint & primers, offering higher:

- PROTECTION AND VISIBILITY  
The guard acts as a shield that prevents wire, dust and any other kind of projections from reaching the user during work.
- FLEXIBILITY  
The adaptability of the material of the guard makes the brush suitable for work not only on open surfaces but also on difficult areas.

### NORMAL STEEL CRIMPED WIRE (NOSCW)

SHAPE	D	A	WIRE Ø	L	PK QTY	ART. NO.
CPB	75	M14	0,30	T22	12	66261103049

### STAINLESS STEEL TWIST KNOTTED WIRE (STSKW)

SHAPE	D	A	WIRE Ø	L	PK QTY	ART. NO.
CPB	75	M14	0,30	T22	12	66261103176

### SHAPE KEY

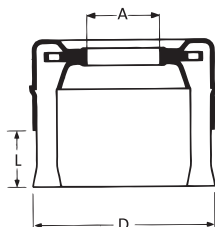

# WIRE BRUSHES FOR HAND DRILLS

## FEATURES

- Ideal for medium force brushing
- Available in crimped and knotted wire
- Inox wire contains less oil

## BENEFITS

- For difficult-to-reach areas (holes, tubes)
- Steady brushing
- Knotted wire for heavy brushing, crimped wire for normal brushing



## CIRCULAR BRUSHES ON SHANK (WHB)



### NORMAL STEEL CRIMPED WIRE (NOSCW)

SHAPE	D	B	SHANK	WIRE Ø	L	PK QTY	ART. NO.
WHB	20	4	6	0,20	T3	10	66254404872
	20	9	6	0,20	T3	10	66254404903
	30	6	6	0,20	T6,5	10	66254404875
	30	9	6	0,20	T6,5	10	66254404876
	40	9	6	0,20	T9	10	66254404879
	40	13,5	6	0,20	T9	10	66254404904
	50	10	6	0,20	T12,5	10	66254404880
	50	15	6	0,20	T12,5	10	66254404881
	60	10	6	0,20	T17,5	10	66254404884
	60	15	6	0,20	T17,5	10	66254404885
	70	10	6	0,20	T19	10	66254404886
	70	15	6	0,20	T19	10	66254404887
	80	10	6	0,20	T19	10	66254404889
	80	20	6	0,20	T19	10	66254404905
	50	10	6	0,30	T12,5	10	66254404891
	50	15	6	0,30	T12,5	10	66254404893
	60	10	6	0,30	T17,5	10	66254404894*
	60	15	6	0,30	T17,5	10	66254404897
	60	20	6	0,30	T17,5	10	66254411025*
	70	10	6	0,30	T19	10	66254404899
70	15	6	0,30	T19	10	66254404900	
80	20	6	0,30	T19	10	66254404907*	



\* Made-to-order

**Dimensions Key:** D = Diameter, B = Width, A = Bore min, L = Wire Length

CLEANING,  
POLISHING  
& MASKING

PERSONAL  
PROTECTION  
EQUIPMENT

TECHNICAL  
INFORMATION



# WIRE BRUSHES FOR HAND DRILLS

## STAINLESS STEEL CRIMPED WIRE (STSCW)



SHAPE	D	B	SHANK	WIRE Ø	L	PK QTY	ART. NO.
WHB	30	9	6	0,20	T6,5	10	66254404909
	40	9	6	0,20	T9	10	66254404910
	40	13,5	6	0,20	T9	10	66254404912*
	50	10	6	0,20	T12,5	10	66254404915
	50	15	6	0,20	T12,5	10	66254405238
	60	10	6	0,20	T17,5	10	66254405269
	60	15	6	0,20	T17,5	10	66254405270
	70	10	6	0,20	T19	10	66254405271
	70	15	6	0,20	T19	10	66254405390*
	80	20	6	0,20	T19	10	66254405392*
	60	10	6	0,30	T17,5	10	66254405393
	60	15	6	0,30	T17,5	10	66254405394*
	70	10	6	0,30	T19	10	66254405395
	70	15	6	0,30	T19	10	66254405396
80	20	6	0,30	T19	10	66254405398	

## BRASS CRIMPED WIRE (BRACW)



WHB	30	9	6	0,20	T6,5	10	66254405400*
	40	9	6	0,20	T9	10	66254405401*
	50	15	6	0,20	T12,5	10	66254405397
	60	15	6	0,20	T17,5	10	66254405402*
	70	15	6	0,20	T19	10	66254405403*
	80	20	6	0,20	T19	10	66254405405

## NORMAL STEEL TWIST KNOTTED WIRE (NOSKW)



WHB	70	15	6	0,35	T15	12	66254405406
	70	15	6	0,50	T15	12	66254405407

\* Made-to-order



## END BRUSHES ON SHANK (ENB)



### NORMAL STEEL CRIMPED WIRE (NOSCW)

SHAPE	D	B	SHANK	WIRE Ø	L	PK QTY	ART. NO.
ENB	12	60	6	0,20	T20	12	66254405408
	17	65	6	0,20	T22	12	66254405409
	12	60	6	0,30	T20	12	66254405410
	17	65	6	0,30	T22	12	66254405411
	24	68	6	0,30	T25	12	66254405412
	30	68	6	0,30	T25	12	66254405413



### STAINLESS STEEL CRIMPED WIRE (STCSW)

ENB	12	60	6	0,30	T20	12	66254405414
	17	65	6	0,30	T22	12	66254405415
	24	68	6	0,30	T25	12	66254405418*
	30	68	6	0,30	T25	12	66254405419

### NORMAL STEEL TWIST KNOTTED WIRE (NOSKW) - HIGH SPEED

ENB	19	68	6	0,35	T28	12	66254405421
	22	68	6	0,35	T28	12	66254405422*
	28	68	6	0,50	T28	12	66254405423



### STAINLESS STEEL KNOTTED WIRE (STSKW) - HIGH SPEED

ENB	19	68	6	0,25	T28	12	66254405424*
	22	68	6	0,25	T28	12	66254405425

### SPECIALTIES

ENB	50	63	6	0,30	T20	5	66254405428*
	70	68	6	0,30	T25	5	66254405429*
	10	120	6	0,30	T20	10	66254405430

\* Made-to-order

**Dimensions Key:** D = Diameter, B = Width, L = Wire Length

SHAPE KEY

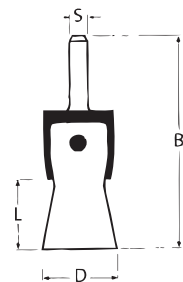

CLEANING,  
POLISHING  
& MASKING

PERSONAL  
PROTECTION  
EQUIPMENT

TECHNICAL  
INFORMATION

# WIRE BRUSHES

## FEATURES

- Ideal for simple brushing operations
- Ideal for difficult-to-reach areas (corners, tubes, holes)
- Ideal for small parts

## BENEFITS

- Flexible, easy to use
- Available in steel, inox and brass
- Good price/performance ratio



## HAND BRUSHES (HCB)



### WOOD HAND - NORMAL STRAIGHT STEEL WIRE (NOSSW)

SHAPE	L1	L2	L	WIRE Ø	ROW	PK QTY	ART. NO.
HCB	290	140	25	0,30	1R	12	66254405431
	290	140	25	0,30	2R	12	66254405432
	290	140	25	0,30	3R	12	66254405434
	290	140	25	0,30	4R	12	66254405435
	290	140	25	0,30	5R	12	66254405437
	290	140	25	0,30	6R	12	66254405439*

### WOOD HAND - STAINLESS STEEL STRAIGHT WIRE (STSSW)

HCB	290	140	25	0,30	2R	12	66254405443*
	290	140	25	0,30	3R	12	66254405444*
	290	140	25	0,30	4R	12	66254405447
	290	140	25	0,30	5R	12	66254405449*

### WOOD HAND - STAINLESS STEEL CRIMPED WIRE (STSCW)

HCB	290	140	25	0,30	2R	12	66254405457
	290	140	25	0,30	3R	12	66254405460*
	290	140	25	0,30	4R	12	66254405461
	290	140	25	0,30	5R	12	66254405462*

### WOOD HAND - BRASS CRIMPED WIRE (BRACW)

HCB	290	140	25	0,30	2R	12	66254405463*
	290	140	25	0,30	3R	12	66254405465*
	290	140	25	0,30	4R	12	66254405466
	290	140	25	0,30	5R	12	66254405467
	290	140	25	0,30	6R	12	66254405468

### SHAPE KEY

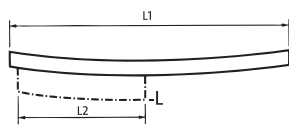

\* Made-to-order

## MULTI HAND BRUSHES

### PLASTIC HAND - NORMAL CRIMPED WIRE (NOSCW)

SHAPE	L1	L2	L	WIRE Ø	PK QTY	ART. NO.
HCB	265	140	25	0,30	6	66254405470

### PLASTIC HAND - STAINLESS STEEL CRIMPED WIRE (STSCW)

HCB	265	140	25	0,30	6	66254405471
-----	-----	-----	----	------	---	-------------

### PLASTIC HAND - BRASS CRIMPED WIRE (BRACW)

HCB	265	140	25	0,30	6	66254405473
-----	-----	-----	----	------	---	-------------



## SPECIAL HAND BRUSHES

### SPARK PLUG BRUSHES

SHAPE	L1	L2	L	WIRE Ø	ROW	PK QTY	ART. NO.
SPB	200	18	45	0,20	3x6R	24	66254405474
	195	26	50	0,20	5x8R	24	66254405478



### FILE CARD BRUSHES

SHAPE	L1	L2	L	PK QTY	ART. NO.
SPB	235	25	100	24	66254405479*
	235	40	115	24	66254405480*



### FITTING BRUSH INTERNAL

SHAPE	D	L	L1	WIRE Ø	PK QTY	ART. NO.
SPB	13	25	160	0,20	12	66254405481*
	16	25	160	0,20	12	66254405483*
	23	32	160	0,20	12	66254405484*



### FITTING BRUSH EXTERNAL

SHAPE	D	WIRE Ø	PK QTY	ART. NO.
SPB	12	0,30	12	66254405485*
	15	0,30	12	66254405486*
	22	0,30	12	66254405487

\* Made-to-order

**Dimensions Key:** D = Diameter, B = Width, L = Wire Length

# WIRE BRUSHES

## PIPE BRUSHES



### PIPE BRUSHES WITH SHANK

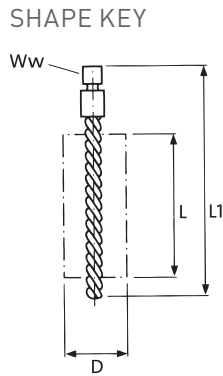

SHAPE	D	L	L1	SHANK / W/w	WIRE Ø	PK QTY	ART. NO.
TUB	16	80	115	6	0,20	10	66254405500*
	18	80	115	6	0,20	10	66254405502
	25	80	115	6	0,20	10	66254405503
TUB	10	80	115	M6	0,20	10	66254405504*
	12	80	115	M6	0,20	10	66254405506*
	16	80	115	M6	0,20	10	66254405507*
	20	80	115	M6	0,20	10	66254405628*
DOU	1000					1	66254405629*
TUB	20	100	160	1/2"BSW	0,20	10	66254405630*
	25	100	160	1/2"BSW	0,20	5	66254405631
	30	100	160	1/2"BSW	0,30	5	66254405632*
	32	100	160	1/2"BSW	0,30	5	66254405634
	38	100	160	1/2"BSW	0,30	5	66254405637*
	44	100	160	1/2"BSW	0,30	5	66254405641*
	50	100	160	1/2"BSW	0,40	5	66254405647
	63	100	160	1/2"BSW	0,40	5	66254405649*
	69	100	160	1/2"BSW	0,40	5	66254405652*
	75	100	160	1/2"BSW	0,40	5	66254405656*
	82	100	160	1/2"BSW	0,40	5	66254411027*
DOU	1000					1	66254405692

### PIPE BRUSHES WITH HANDLE NORMAL STEEL CRIMPED

SHAPE	D	L	L1		WIRE Ø	PK QTY	ART. NO.
ACB	6	100	300	+ handle	0,10	20	66254405662*
	8	100	300	+ handle	0,10	20	66254405696*
	10	100	300	+ handle	0,10	20	66254405706
	12	100	300	+ handle	0,10	20	66254405704
	15	100	300	+ handle	0,10	20	66254405712
	18	100	300	+ handle	0,10	20	66254405713
	20	100	300	+ handle	0,20	20	66254405715
	25	100	300	+ handle	0,20	20	66254405717

### PIPE BRUSHES WITH HANDLE STAINLESS STEEL CRIMPED

ACB	12	100	300	+ handle	0,10	20	66254405720*
	15	100	300	+ handle	0,10	20	66254405722

\* Made-to-order

PIPE BRUSHES WITH HANDLE BRASS WIRE

SHAPE	D	L	L1		WIRE Ø	PK QTY	ART. NO.
ACB	6	100	300	+ handle	0,10	20	66254405723
	8	100	300	+ handle	0,10	20	66254405724*
	10	100	300	+ handle	0,10	20	66254405725
	12	100	300	+ handle	0,10	20	66254405726*
	15	100	300	+ handle	0,10	20	66254405727*
	18	100	300	+ handle	0,10	20	66254405728*
	20	100	300	+ handle	0,15	20	66254405730*
	25	100	300	+ handle	0,15	20	66254405731*



PIPE BRUSHES WITH HANDLE NYLON WIRE

ACB	6	100	300	+ handle	0,20	20	66254405732
	8	100	300	+ handle	0,20	20	66254405733*
	10	100	300	+ handle	0,20	20	66254405734*
	12	100	300	+ handle	0,20	20	66254405735*
	15	100	300	+ handle	0,20	20	66254405737
	18	100	300	+ handle	0,25	20	66254405739*
	20	100	300	+ handle	0,25	20	66254405740*
	25	100	300	+ handle	0,25	20	66254405742*

MISCELLANEOUS



BROOM STEELWIRE

SHAPE	B	D	ROW	L	PK QTY	ART. NO.
SPB	300	60	6x20	T75	1	66254405744



SCRUBBER STEELWIRE

SPB	210	60	6x17	T30	1	66254405745
-----	-----	----	------	-----	---	-------------

\* Made-to-order

**Dimensions Key:** D = Diameter, B = Width, L = Wire Length

CLEANING,  
POLISHING  
& MASKING

PERSONAL  
PROTECTION  
EQUIPMENT

TECHNICAL  
INFORMATION



# TUNGSTEN CARBIDE BURRS

State of the art, "Inox" & "Steel" cut styles, new round edge burrs and fiberglass routers brings innovation to the Norton Carbide burr offering. The specially designed geometries suit the growing market demands for stainless steel, steel, cast steel and composites applications offering fast stock removal and long service life, providing optimum efficiency.

This extended line of carbide burrs covers a variety of teeth and cutting shapes providing optimum adaptation to the key characteristics of various application materials.

Carbide burrs can be used on with hand-held tools or CNC machines. Each carbide burr is packed individually in a plastic case.

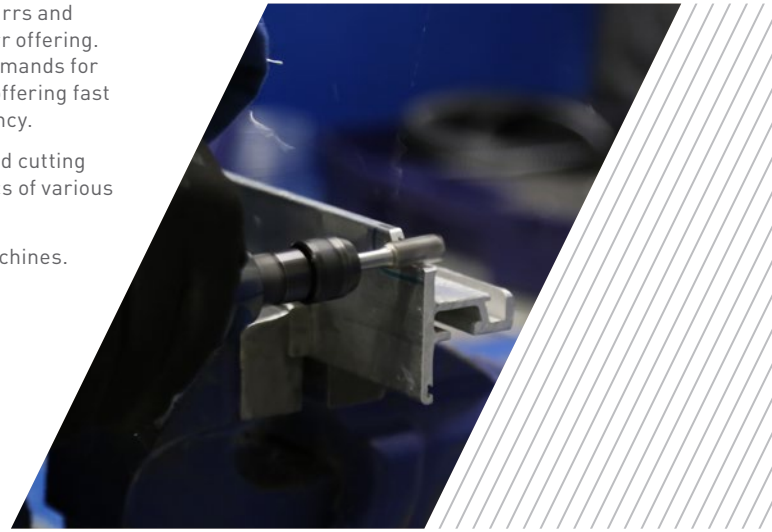

## APPLICATIONS & MARKETS





- Weld removal
- Chamfering
- Weld preparation
- Deburring
- Aerospace
- Automotive
- Shipbuilding
- Foundry
- Aviation

## UNDERSTANDING THE PRODUCT

### BURR DIMENSIONS & DESCRIPTION

A	16,0	x	25,0	6x65	DTECH
Shape	Head diameter		Head length	Shank diameter & overall burr length (OL)	Cut style
	$D_1$		$L_1$	$D_2 + L_2$	

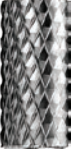
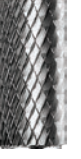
## APPLICATION BY CUT STYLE

						
Cut Style	INOX	STEEL	DTECH Double Cut Extra	D Double Cut	ALU Aluminium Special	Fiberglass routers
Qualities	Developed cutting geometry - generating high stock removal on stainless steel and on Ferritic, Austenitic & Martensitic based materials, ensuring production savings and reduced downtime, reducing heat buildup at the cutting edge and work piece.	Specially designed geometry to suit growing market demands for steel and cast steel applications, producing large chips with increased stock removal.	Better stock removal. Stronger tooth formation (decreased tooth wedge angle) longer tool life and reduced chipping.	Universal cutting style, fast material removal, smooth finish and granular chip break.	For deburring of aluminium alloys & plastic wide tooth formation, easy chip flow.	Best for Carbon or Glass fibre reinforced materials. Best for roughing and contouring composite.

Stainless Steel	+++++		+++			
Hardened Steel		+++++	+++			
Cast Iron			+++++	+++		
Titanium				+++++		
Nickel				+++++		
Copper/ copper alloys				+++++		
Aluminium					+++++	
Plastics / wood					+++++	
Carbon or glass fibers						+++++

## APPLICATION BY SHAPE

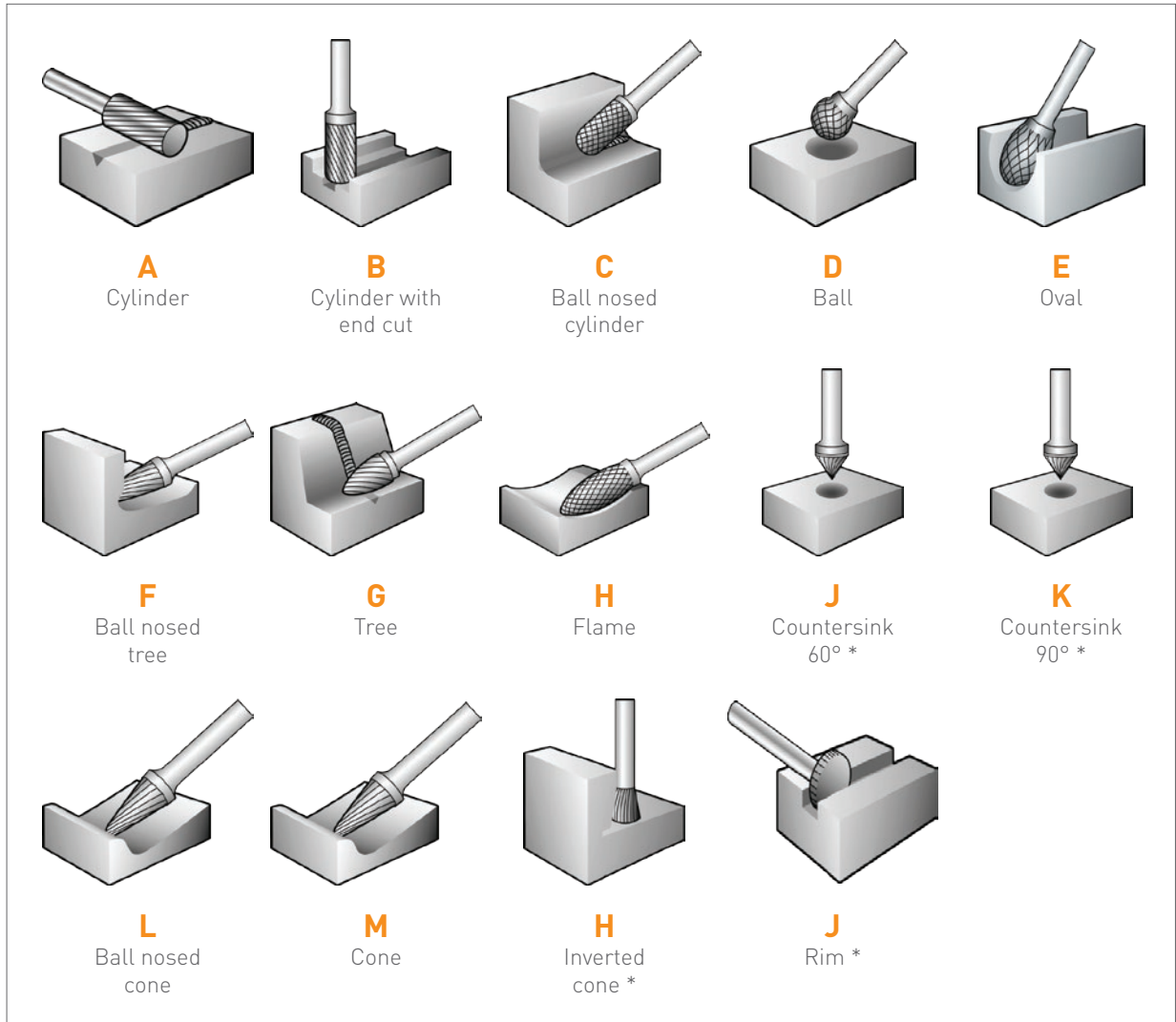

\* Made-to-order



## RECOMMENDED OPERATING SPEEDS (RPM)

MATERIAL TYPE	∅	∅	∅	∅	∅
	3mm	6mm	10mm	12mm	16mm
Steel	60000-90000	45000-90000	30000-40000	22500-30000	18000-24000
Tempered steel	60000-90000	30000-45000	19000-30000	15000-22500	12000-18000
Stainless steel	60000-90000	30000-45000	19000-30000	15000-22500	12000-18000
Casting	45000-90000	22500-60000	15000-40000	11000-30000	9000-24000
Titanium	60000-90000	30000-45000	19000-30000	15000-22500	12000-18000
Nickel	60000-90000	30000-45000	19000-30000	15000-22500	12000-18000
Copper & copper alloys	45000-90000	22500-60000	15000-40000	11000-30000	9000-24000
Aluminium	30000-90000	15000-70000	10000-50000	7000-38000	6000-30000
Plastics	30000-90000	15000-70000	10000-50000	7000-38000	6000-30000
Carbon or glass fibers	64000-117000	32000-59000	19000-35000	16000-30000	12000-22000

Recommended speeds are for standard shank length of 45mm, maximum overhang 10mm. Maximum recommended speed for extra long burrs is 15000 RPM.

## RECOMENDATIONS FOR USE

- It may be necessary to adjust the rates shown to achieve optimum performance
- Running below the optimum speed will encourage chipping
- Harder materials or sticky metals such as, titanium, require slower speeds
- Running above optimum speed will cause tooth wear
- Smaller burrs require faster speeds
- Allowing the tool to become too hot may cause the braze to melt and detach the head of the shank
- Apply constant movement and light pressure when in use
- Do not sink the burr for more than one third of its periphery



## CARBIDE BURRS FOR STAINLESS STEEL



### FEATURES AND BENEFITS:

- Special cut style "INOX" for higher stock removal and reduced heat build up at the cutting edge and workpiece
- Aggressive cut creating large chips ensures production savings and reduced downtime



PRODUCT SHAPE	DIM D <sup>1</sup> xL <sup>1</sup> xD <sup>2</sup> xL <sup>2</sup> (mm)	PK QTY	BEST	
<b>A</b> CYLINDER 	6x18x6x50	1	66261121900	
	8x19x6x64	1	66261121901	
	10x19x6x64	1	66261121902	
	13x25x6x70	1	66261121911	
<b>C</b> BALL NOSED CYLINDER 	6x18x6x50	1	66261121912	
	8x19x6x64	1	66261121920	
	10x19x6x64	1	66261121921	
	13x25x6x70	1	66261121922	
<b>D</b> BALL 	6x5x6x50	1	66261122103	
	8x6x6x52	1	66261122107	
	10x8x6x54	1	66261122108	
	13x11x6x56	1	66261122109	
<b>F</b> BALL NOSED TREE 	6x18x6x50	1	66261122110	
	8x20x6x65	1	66261122111	
	10x19x6x64	1	66261122114	
	13x25x6x70	1	66261122115	
<b>G</b> TREE 	6x18x6x50	1	66261122116	
	8x19x6x64	1	66261122118	
	10x19x6x64	1	66261122119	
	13x25x6x70	1	66261122120	
<b>L</b> BALL NOSED CONE 	8x25x6x70	1	66261122122	
	10x20x6x65	1	66261122123	
	13x32x6x77	1	66261122125	
<b>INOX KIT</b> 	A	13x25x6x70	1	66261122126
	C	13x25x6x70	1	
	F	13x25x6x70	1	
	G	13x25x6x70	1	
	L	13x32x6x77	1	

## CARBIDE BURRS FOR STEEL



### FEATURES AND BENEFITS:

- Special cut style "STEEL" generating lower heat at cutting edge and workpiece
- Aggressive cut producing large chips with increased stock removal, production savings and reduced downtime



PRODUCT SHAPE	DIM D <sup>1</sup> xL <sup>1</sup> xD <sup>2</sup> xL <sup>2</sup> (mm)	PK QTY	BEST	
<b>B</b> CYLINDER WITH END CUT 	6x18x6x50	1	66261121688	
	8x19x6x64	1	66261121691	
	10x19x6x64	1	66261121692	
	13x25x6x70	1	66261121694	
<b>C</b> BALL NOSED CYLINDER 	6x18x6x50	1	66261121748	
	8x19x6x64	1	66261121749	
	10x19x6x64	1	66261121750	
	13x25x6x70	1	66261121751	
<b>D</b> BALL 	6x5x6x50	1	66261121753	
	8x6x6x52	1	66261121755	
	10x8x6x54	1	66261121756	
	13x11x6x56	1	66261121757	
<b>F</b> BALL NOSED TREE 	6x18x6x50	1	66261121759	
	8x20x6x65	1	66261121760	
	10x19x6x64	1	66261121747	
	13x25x6x70	1	66261121762	
<b>G</b> TREE 	6x18x6x50	1	66261121763	
	8x19x6x64	1	66261121764	
	10x19x6x64	1	66261121765	
	13x25x6x70	1	66261121766	
<b>L</b> BALL NOSED CONE 	10x20x6x65	1	66261121767	
	10x30x6x76	1	66261121768	
	13x32x6x77	1	66261121769	
<b>STEEL KIT</b> 	B	13x25x6x70	1	66261121783
	C	13x25x6x70	1	
	F	13x25x6x70	1	
	G	13x25x6x70	1	
	L	13x32x6x77	1	

**Dimensions Key:** DIM = Dimensions, D<sup>1</sup> = Head Diameter, L<sup>1</sup> = Head Length, D<sup>2</sup> = Shank Diameter, L<sup>2</sup> = Shank Length

CLEANING,  
POLISHING  
& MASKING

PERSONAL  
PROTECTION  
EQUIPMENT

TECHNICAL  
INFORMATION



## CARBIDE BURRS FOR CAST IRON & SOFT STEELS



**BEST +++++**







### FEATURES AND BENEFITS:

- "DTECH" Double Cut EXTRA cut style COATED with TiALN (Titanium aluminium nitride) for better sliding characteristics, improved removal of chippings, less wear of tooling, Less heat build up and Reduction of cutting pressure due to improved lubrication.

**BETTER ++++**

### FEATURES AND BENEFITS:

- "DTECH" cut style Double Cut Extra, Better stock removal. Stronger tooth formation (decreased tooth wedge angle). Longer tool life. Reduced chipping.
- Available on a wide variety of shapes and sizes.

PRODUCT SHAPE	DIM D <sup>1</sup> xL <sup>1</sup> xD <sup>2</sup> xL <sup>2</sup> (mm)	PK QTY	DOUBLE CUT	
			COATED BEST	BETTER
A CYLINDER 	3x13x3x38	1		66254477143
AR CYLINDER WITH RADIUS 	6x5x6x150	1		66261140272*
	6x5,4x6x50	1		66261140336*
	10x9x6x53	1		66261140337
	12x10,8x6x55	1		66261140338*
B CYLINDER WITH END CUT 	3x13x3x38	1		07660739844*
	6x19x6x50	1		60157638174
C BALL NOSED CYLINDER 	3x13x3x38	1	69957383238*	07660739841
	6x13x6x162	1	69957383277*	60157638175
F BALL NOSED TREE 	6x5,4x6x50	1	69957383321*	63642587067
L BALL NOSED CONE 	10x9x6x53	1	69957383279	07660707832

\* Made-to-order

NEW SHAPES FOR SPECIAL APPLICATIONS



PRODUCT SHAPE	DIM D <sup>1</sup> xL <sup>1</sup> xD <sup>2</sup> xL <sup>2</sup> (mm)	PK QTY	BETTER
CMN	12x25x6x70	1	66261140427*
DN	12x20x6x65	1	66261140430*
KMN	12x28x6x73	1	66261140595*
KN	12x18x6x63	1	66261140596*
LMN	12x35x6x80	1	66261140686*

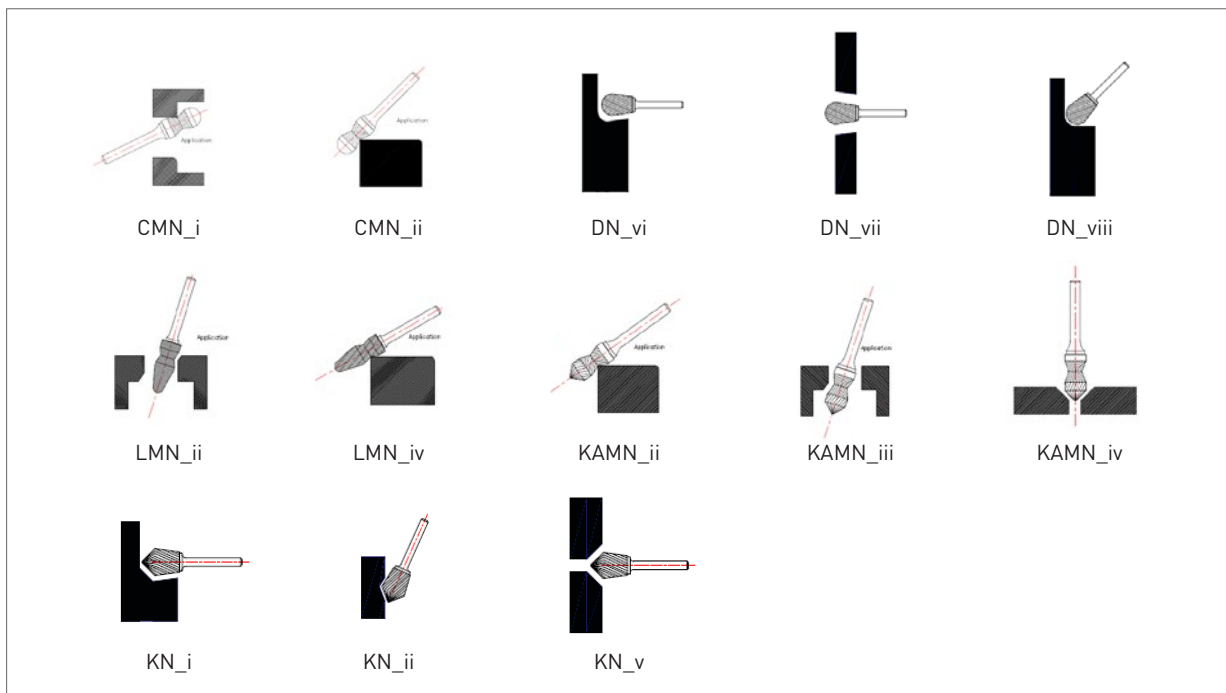

KIT	SHAPE	DIM D <sup>1</sup> xL <sup>1</sup> xD <sup>2</sup> xL <sup>2</sup> (mm)	PK QTY	BETTER
BURRS KIT x10 CUT DTECH NORTON	A	10x19x6x65	1	7660739870*
	A	12x25x6x70	1	
	C	10x19x6x65	1	
	C	12x25x6x70	1	
	L	12x30x6x75	1	
	E	10x16x6x60	1	
	G	10x19x6x65	1	
	G	12x25x6x70	1	
	D	12x10,8x6x55	1	
	F	12x25x6x70	1	
SOFT STEELS	C	12x25x6x70	1	66254428281
	D	10x9x6x53	1	
	F	12x25x6x70	1	
	L	12x30x6x75	1	

\* Made-to-order

**Dimensions Key:** DIM = Dimensions, D<sup>1</sup> = Head Diameter, L<sup>1</sup> = Head Length, D<sup>2</sup> = Shank Diameter, L<sup>2</sup> = Shank Length

CLEANING,  
POLISHING  
& MASKING

PERSONAL  
PROTECTION  
EQUIPMENT

TECHNICAL  
INFORMATION

## CARBIDE BURRS FOR TITANIUM, NICKEL, COPPER AND COPPER ALLOYS



### BEST +++++

#### FEATURES AND BENEFITS:

- "D" Double cut style COATED with TiALN (Titanium aluminium nitride) for better sliding characteristics, improved removal of chippings, less wear of tothing, Less heat build up and reduction of cutting pressure due to improved lubrication.





### BETTER ++++







#### FEATURES AND BENEFITS:

- "D" Double CUT style, universal cutting style for fast material removal, smooth finish and granular chip break.
- Sharp cutting edges for improved productivity & longer product life.
- Available on a wide variety of shapes and sizes.



PRODUCT SHAPE	DIM D <sup>1</sup> xL <sup>1</sup> xD <sup>2</sup> xL <sup>2</sup> (mm)	PK QTY	DOUBLE CUT COATED	
			BEST	BETTER
<b>A</b> CYLINDER 	3x13x3x38	1		63642586518
	6x19x6x50	1	69957383214	60157638141
	8x19x6x65	1		60157638143
	10x19x6x65	1	69957383215*	60157638144
	10x25x6x162	1		63642535764
	12x25x6x70	1	69957383219	07660707808
	16x25x6x70	1		60157638148
<b>B</b> CYLINDER WITH END CUT 	3x13x3x38	1		60157638140
	6x19x6x50	1		63642586641
	8x19x6x65	1		7660707804
	8x19x6x175	1		63642535757
	10x19x6x65	1		60157638145
	12x25x6x70	1		60157638147
	16x25x6x70	1		60157638190
<b>C</b> BALL NOSED CYLINDER 	3x13x3x38	1		63642586710
	6x13x6x162	1		63642535773
	6x16x6x80	1		66261197806
	6x19x6x50	1	69957383234	60157638150
	8x19x6x65	1		60157638151
	10x19x6x65	1	69957383236	60157638152
	12x19x6x65	1		60157638153
	12x25x6x70	1	69957383241	60157638154
	16x25x6x70	1		60157638191

\* Made-to-order

PRODUCT SHAPE	DIM D <sup>1</sup> xL <sup>1</sup> xD <sup>2</sup> xL <sup>2</sup> (mm)	PK QTY	DOUBLE CUT	
			COATED BEST	BETTER
<b>D</b> BALL 	6x5x6x150	1		63642535770*
	6x5,4x6x50	1		60157638166
	8x7,2x6x52	1		60157638167
	10x9x6x53	1	69957383279	7660707832
	12x10,8x6x55	1	69957383281	69957383148
<b>E</b> OVAL 	6x10x6x50	1		63642586892
	10x16x6x60	1		60157638159
	12x22x6x67	1		60157638162
<b>F</b> BALL NOSED TREE 	6x16x6x50	1	69957383296*	63642586955
	6x18x6x150	1		66623391628
	8x20x6x150	1		66623382151
	10x19x6x65	1	69957383299	60157638170
	12x25x6x70	1	69957383301	60157638171
	12x25x8x70	1		60157638172
	16x25x6x70	1		63642586952
<b>G</b> TREE 	3x12x3x38	1	69957351490	60157638163
	6x16x6x50	1	69957383305*	60157638164
	10x19x6x65	1	69957383307	60157638165
	12x25x6x70	1		7660707829
	16x25x6x70	1		63642586980
<b>H</b> FLAME 	8x19x6x65	1		60157638160
	12x32x6x77	1	69957383312	63642587971
<b>L</b> BALL NOSED CONE 	6x16x6x50	1	69957383313*	60157638156
	8x19x6x69	1		63642587104
	10x27x6x75	1		63642587100
	12x30x6x75	1	69957383320	63642587102
<b>M</b> CONE 	6x19x6x50	1	69957383326*	63642587137
	6x25x6x50	1		63642587138*
	10x16x6x65	1		63642587133
	12x22x6x70	1	69957383328	60157638149

\* Made-to-order

**Dimensions Key:** DIM = Dimensions, D<sup>1</sup> = Head Diameter, L<sup>1</sup> = Head Length, D<sup>2</sup> = Shank Diameter, L<sup>2</sup> = Shank Length

CLEANING,  
POLISHING  
& MASKING

PERSONAL  
PROTECTION  
EQUIPMENT

TECHNICAL  
INFORMATION

KIT	SHAPE	DIM D <sup>1</sup> xL <sup>1</sup> xD <sup>2</sup> xL <sup>2</sup> (mm)	PK QTY	BETTER
MINI BURRS KIT x10 CUT D NORTON	A	3x13x3x38	1	07660708056
	B	3x13x3x38	1	
	M	3x11x3x38	1	
	C	3x13x3x38	1	
	L	3x8x3x38	1	
	H	3x8x3x38	1	
	E	3x6x3x38	1	
	G	3x13x3x38	1	
	D	3x2,7x3x39	1	
	F	3x13x3x38	1	
BURRS KIT x5 CUT D NORTON	A	10x19x6x65	1	63642553618
	C	12x25x6x70	1	
	F	12x25x6x70	1	
	G	10x19x6x65	1	
	L	12x30x6x75	1	
BRASS, BRONZE, COPPER	C	12x25x6x70	1	66254428265
	D	10x9x6x53	1	
	F	12x25x6x70	1	
	L	12x30x6x75	1	

CLEANING,  
POLISHING  
& MASKING

PERSONAL  
PROTECTION  
EQUIPMENT

TECHNICAL  
INFORMATION



## CARBIDE BURRS FOR ALUMINIUM



**BEST +++++**





### FEATURES AND BENEFITS:

- "ALU" cut syle COATED with TiALN (Titanium aluminium nitride) for better sliding characteristics, improved removal of chippings, less wear of toothing, Less heat build up and Reduction of cutting pressure due to improved lubrication.

**BETTER ++++**

### FEATURES AND BENEFITS:

- Cut style "ALU" for deburring of aluminium alloys & plastic. Wide tooth formation for easy chip flow .

PRODUCT SHAPE	DIM D <sup>1</sup> xL <sup>1</sup> xD <sup>2</sup> xL <sup>2</sup> (mm)	PK QTY	ALU COATED	ALU
			BEST	BETTER
<b>A</b> CYLINDER 	10x19x6x65	1	69957383216	60157638195
	12x25x6x70	1	69957383220*	63642586517
<b>B</b> CYLINDER WITH END CUT 	10x19x6x65	1		07660739845
<b>C</b> BALL NOSED CYLINDER 	10x19x6x65	1	69957383239*	60157638182
	12x25x6x70	1	69957383278*	07660707846
<b>F</b> BALL NOSED TREE 	10x19x6x65	1	69957383300	63642586951
	12x25x6x70	1	69957383303	60157638181
<b>L</b> BALL NOSED CONE 	6x16x6x50	1		63642587095*
	12x30x6x75	1	69957383325	63642587101
ALUMINIUM KIT	C	12x25x6x70	1	66254428260
	D	10x9x6x53	1	
	F	12x25x6x70	1	
	L	12x30x6x75	1	

\* Made-to-order

**Dimensions Key:** DIM = Dimensions, D<sup>1</sup> = Head Diameter, L<sup>1</sup> = Head Length, D<sup>2</sup> = Shank Diameter, L<sup>2</sup> = Shank Length



## FIBERGLASS ROUTER



BEST +++++

### FEATURES AND BENEFITS:

- Best for trimming, routing and pocketing applications on composite, Carbon and Glass fibre reinforced materials
- Can be used on various material with hand-held tools or CNC machines
- Special cut style allows precise machining. Select the different tooth geometry to drill (plunge) into the material or optimal facing application

### NO END CUT



PRODUCT SHAPE	DIM D <sup>1</sup> xL <sup>1</sup> xD <sup>2</sup> xL <sup>2</sup> (mm)	PK QTY	ART. NO.
Router No End Cut	3x13x3x45	1	66261140775
	6x19x6x63	1	66261140784
	8x25x8x63	1	66261140788
	10x25x10x63	1	66261140689*
	12x30x12x75	1	66261140697*

### BUR STYLE



PRODUCT SHAPE	DIM D <sup>1</sup> xL <sup>1</sup> xD <sup>2</sup> xL <sup>2</sup> (mm)	PK QTY	ART. NO.
Bur Style	3x13x3x45	1	66261140777
	6x19x6x63	1	66261140786
	8x25x8x63	1	66261140793
	10x25x10x63	1	66261140695*
	12x30x12x75	1	66261140700*

### ENDMILL



PRODUCT SHAPE	DIM D <sup>1</sup> xL <sup>1</sup> xD <sup>2</sup> xL <sup>2</sup> (mm)	PK QTY	ART. NO.
Endmill	3x13x3x45	1	66261140779
	6x19x6x63	1	66261140787
	8x25x8x63	1	66261140797
	10x25x10x63	1	66261140696*
	12x30x12x75	1	66261140702*

### DRILLPOINT



PRODUCT SHAPE	DIM D <sup>1</sup> xL <sup>1</sup> xD <sup>2</sup> xL <sup>2</sup> (mm)	PK QTY	ART. NO.
Drillpoint	3x13x3x45	1	66261140776
	6x19x6x63	1	66261140785
	8x25x8x63	1	66261140792
	10x25x10x63	1	66261140693*
	12x30x12x75	1	66261140698*

\* Made-to-order

# STEEL WOOL

For cleaning a variety of materials and highlighting and rubbing wood. Washable and reusable. Won't rust, shred or splinter. Compatible with water based finishes. Synthetic Steel Wool is one of top NORTON quality items.

## APPLICATIONS & MARKETS

- Sanding contours & intricate shapes
- Restoring wood surfaces
- Finishing
- Removing minor defects
- Clear coat sanding
- Base coat sanding



## STANDARD

BETTER ++++



### FEATURES

- Made from strands of ultra-fine steel filaments

### BENEFITS

- For use on wood, paint, metal, stone, marble & glass
- Can be used with a chemical stripper
- Ideal for cleaning & fine finishing

WEIGHT	GRADE	PK QTY	ART. NO.
1kg	0000	12	63642593149
1kg	000	12	63642593151
1kg	00	12	63642593153
1kg	0	12	63642593154

CLEANING,  
POLISHING  
& MASKING

PERSONAL  
PROTECTION  
EQUIPMENT

TECHNICAL  
INFORMATION

# CLEANING & POLISHING PRODUCTS

Norton cleaning & polishing products are designed to provide excellent results, save time and increase efficiency. Pure Ice Q175 and Norton Ice combined with Liquid Ice provide a complete system to achieve a flawless finish. The exceptionally uniform cut of Pure Ice Q175 provides a consistent finish that significantly reduces polishing time. Using Liquid Ice produces an exceptionally fine finish. Get the job done faster and right the first time. New Norton Ice foam backed discs are ideal for polishing out faster on spot repair applications. When only the perfect finish is acceptable, use the new Liquid Ice polishing compounds and accessories. By reducing the number of polishing steps required, Liquid Ice Xtra Cut, Quick Cut and OEM are a practical solution to improve productivity and quality of work.



## APPLICATIONS & MARKETS

- Automotive
- Marine

## NEW PURE ICE FILM DISCS Q175

BEST +++++



**PUREice**

A strong, thin film backing with premium aluminium oxide abrasive and a patented resin technology sands flat, resists loading, lasts long and cuts consistently for a finish that's faster to buff out. A superior no-fil coating means loading is minimised for even longer sanding life.

### FEATURES

- Patented resin technology
- Consistent, water-based No-Fil stearate application
- Ultra-thin film backing for maximum flexibility
- R&D integral design of film backing and unique resin system
- Colour coded grits

### BENEFITS

- Excellent grain adhesion for long life and consistent cut
- Resists loading to extend disc life and eliminate pigtails
- Even surface provides a very consistent finish that is easier to buff out
- Can conform to irregular surfaces
- Discs stay flat for a superior surface finish
- Easy identification of grit and application

### MOUNTING

For better results, use with the Norton Soft interface pad.  
For detailed information see page 193.

COLOUR	GRIT	76mm			150mm				PK QTY	BOX QTY
		NO HOLES	PK QTY	BOX QTY	7 HOLES	9 HOLES	15 HOLES	MULTI-AIR		
Black	P800	-	-	-	66261110841	66261110855	66261110837	-	50	300
Red	P1000	66261110859	50	100	66261110852	66261110856	66261110838	66261113819	50	300
Green	P1200	-	-	-	66261110853	66261110857	66261110839	-	50	300
Blue	P1500	66261110860	50	100	66261110854	66261110858	66261110840	66261113821	50	300

**NEW** NORTON ICE DISCS Q255

BEST +++++

*ice*

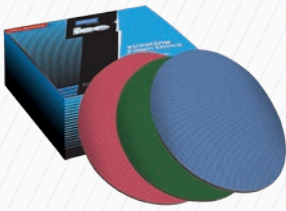

New improved Norton Ice foam backed discs are ideal for polishing out even faster on spot repair applications. The new 'open mesh' backing technology absorbs water and moulds to the surface for equal pressure distribution. Norton Ice also provides a uniformed cut throughout the product life, with a smooth finish and lower scratch depth for a high quality finish.

**FEATURES**

- Ultra fine grits available 1500, 2000 & 3000
- Colour coded discs
- Foam backing absorbs water and moulds to the surface for equal pressure distribution

**BENEFITS**

- Uniform cut throughout product life
- Smooth finish and lower scratch depth
- Requires less effort during the application
- Easy grit identification
- Washable and waterproof
- Reusable
- High quality finish
- Use by hand on difficult to reach areas

DIMENSIONS (mm)	COLOUR	GRADE	ART NO.	PK QTY	BOX QTY
80	Blue	1500	66623324958	12	48
	Fuchsia	2000	66623324955	12	48
	Green	3000	66623324956	12	48
150	Blue	1500	66623324933	15	60
	Fuchsia	2000	66623324952	15	60
	Green	3000	66623324954	15	60



**APPLICATION TIP**

Use Pure Ice and Norton Ice discs with Liquid Ice polishing compounds and Blue Magnet microfibre cloth to achieve a professional high shine finish.

## IMPROVED POLISHING SOLUTIONS

**LIQUID**  
**ice**



When only the perfect finish is acceptable, use Liquid Ice polishing compounds and accessories. By reducing the number of polishing steps required, Liquid Ice Xtra Cut, Quickcut, and OEM are a practical solution to improve productivity and quality of work.

### FEATURES

- 0% silicone
- Waterbased
- Easy to use single and dual step processes

### BENEFITS

- Contamination free
- Environmentally friendly
- Reduces polishing and buffing time

### APPLICATION TIP

A polished finish can be achieved on most common clear coats using only Liquid Ice Xtra Cut, single step process. Use the single step process for quick applications and good results. If holograms appear or if a higher gloss finish is required (on black, metallic or pearl coating), use Liquid Ice Quick Cut and OEM, dual step process. The dual step process gives accurate results and an exceptional finish.

## SINGLE STEP PROCESS

	POLISHING - 1 STEP REMOVE SCRATCHES AFTER 2000 OR FINER	PROTECTION REMOVE EXCESS COMPOUND RESIDUE & PAINT PROTECTION
SINGLE STEP PROCESS	<p>Liquid Ice Xtra Cut + OR + Red Backed White Flat Cutting Foam or Norwool + Red Microfibre Cloth</p> <p>+ CUT INDICATOR - - GLOSS INDICATOR +</p>	<p>Detailer Spray + Black Microfibre Cloth</p>

## DUAL STEP PROCESS

	POLISHING - STEP 1 REMOVE SCRATCHES AFTER 1500	POLISHING - STEP 2 REMOVE HOLOGRAMS & IMPROVE GLOSS (DEEPER COLOUR)	PROTECTION REMOVE EXCESS COMPOUND RESIDUE & PAINT PROTECTION
DUAL STEP PROCESS	<p>Liquid Ice Quick Cut + OR + White Backed White Waffle Cutting Foam + White Microfibre Cloth</p> <p>+ CUT INDICATOR - - GLOSS INDICATOR +</p>	<p>Liquid Ice OEM + Black Backed Black Finishing Flat Foam + Black Microfibre Cloth</p> <p>+ CUT INDICATOR - - GLOSS INDICATOR +</p>	<p>Detailer Spray + Black Microfibre Cloth</p>



## LIQUID ICE - XTRA CUT

**SINGLE STEP  
PROCESS**



Remove in a single step scratches after grade 2000 and finer, use with hard foam or Norwool lambswool for best results. Only one single step is required for the most common top clear coat applications, for high gloss finishing and fast application.

ART NO.	VOLUME	PK QTY
66623339742	1 Litre	6 bottles

## IMPROVED SYSTEM LIQUID ICE - QUICK CUT

**DUAL STEP  
PROCESS**

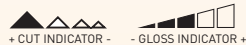

Polish after grade 1500, use with hard foam or Norwool lambswool for best results. Follow with OEM and black backed finishing foam to achieve a perfect gloss finish.

ART NO.	VOLUME	PK QTY
66254429419	1 Litre	6 bottles

## LIQUID ICE - OEM



To remove holograms and clouds and improving gloss for a final finish.

ART NO.	VOLUME	PK QTY
66261191537	1 Litre	6 bottles

## IMPROVED FOAM POLISHING HEADS



The unique combination of density and softness is ideal for polishing and improving shine. The open cell design allows the compound to flow in and is held during use with little or no splattering.

### APPLICATION TIP

For the best comfort in application, use the super comfort support pad.

DESCRIPTION	BACKING COLOUR	VOLUME / DIMENSIONS	DENSITY / SHAPE	ART NO.	PK QTY
Cutting Foam - White Flat	Red	150 x 30mm	Hard Flat	63642537212	10 x 2 pcs
		80 x 25mm		63642537215	4 x 5 pcs
Cutting Foam - White Waffle	White	150 x 30mm	Hard Waffle	63642541644	10 x 2 pcs
		80 x 25mm		63642541544	4 x 5 pcs
Finishing Foam - Black Flat	Black	150 x 30mm	Soft Flat	66254441985	10 x 2 pcs
		80 x 25mm		66254441987	4 x 5 pcs
General Purpose Foam - Orange Flat	-	150 x 50mm	Firm Flat	66623339748	10 x 50 pcs
		150 x 30mm		77696068719	10 x 2 pcs
		80 x 25mm		66623339749	4 x 5 pcs
Support Pad - Super Comfort	-	125mm - M14	Soft	63642541545	10 pcs

### NORWOOL LAMBSWOOL



DESCRIPTION	DIMENSIONS	PK QTY	ART. NO.
Norwool Lambswool	76mm	12	63642567956
	150mm	6	63642567955

### NEW LIQUID ICE DETAILER SPRAY



DESCRIPTION	VOLUME	PK QTY	ART. NO.
Liquid Ice Detailer Spray is designed to easily clean up excess buffing residue and provide excellent paint protection. Simply spray on and wipe off with a Blue Magnet microfibre cloth.	1 Litre	4	63642574651

### NEW MICROFIBRE CLOTHS



DESCRIPTION	DIMENSIONS	PK QTY	ART. NO.
Red microfibre cloth	400x400mm	20	66261108196
White microfibre cloth	400x400mm	20	66261108197
Black microfibre cloth	400x400mm	20	66261108200

### BLUE MAGNET



DESCRIPTION	DIMENSIONS	PK QTY	ART. NO.
Blue Magnet microfibre cloth	400x400mm	5	63642504402

### NORTON BACK-UP PADS



DESCRIPTION	DIMENSIONS	PK QTY	ART. NO.
Norton back-up pad	76mm	6	63642567810
	150mm	3	63642567812

### NORTON ICE STARTER KIT



DESCRIPTION	PK QTY	ART. NO.
The Norton Ice Starter Kit is full selection of finishing & polishing products & accessories. An ideal introduction to the Ice range, the kit contains abrasive microfinishing discs, polishing compounds, foams, pads and a finishing spray to provide a taster of the high technology products Norton has to offer to achieve the perfect finish.	1	66254488515

# MASKING TAPE

Norton Masking Tapes are designed to meet end user demands in many market sectors. All tapes in the range conform easily to contours, adhere to most surfaces and irregular shapes and are resistant to diverse temperatures. Different product characteristics provide excellent results, saving time and increasing efficiency.

## APPLICATIONS & MARKETS

- Industrial
- Building & construction
- DIY
- Marine
- Automotive



## GOLD TAPE

BEST +++++

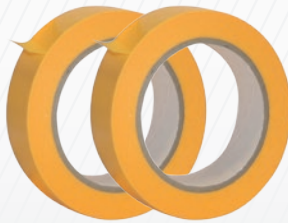

### FEATURES

- Heat resistance (120°C/1hour)
- Conforms to most surfaces
- 1-2 months durability outside

### BENEFITS

- Resistant to high temperature
- High bond strength
- Good adhesion
- Excellent workability
- No adhesive residue after 1-2 months
- Excellent masking line sharpness

Applications:  
Ideal for marine, car body repair, architectural painting process

DIM WxL	PK QTY	ART. NO.
19mmx50m	24	66261067434
25mmx50m	36	66254490982*
38mmx50m	12	66261067435
50mmx50m	18	66254490986

\* Made-to-order



VIDEO LINK



## AUTOMOTIVE APPLICATION VIDEOS

See the products in use in our Norton application videos.

### VIDEO PLAYLIST:

- Sanding Clearcoat & Polishing
- Norton Paint System
- Masking Preparation
- Headlight Repair
- Body Preparation

# PREMIUM MASKING TAPE



Applications:  
Car body repair,  
lacquering applications

### FEATURES

- Semi crepe paper for oven/dry bake painting cycles up to 100°C
- Easy removal at 10°C
- Conforms to contours, irregular shapes and surfaces
- Compatible with most common paints & lacquers

### BENEFITS

- Resistant to high temperature
- No adhesive residue
- Good adhesion
- Removal without ripping

DIM WxL	PK QTY	ART. NO.
19mmx50m	48	69957394601
25mmx50m	36	69957394602
30mmx50m	32	66261193492
38mmx50m	24	69957394603
50mmx50m	24	69957394604

**Dimensions Key:** DIM = Dimensions, W = Width, L = Length



CLEANING,  
POLISHING  
& MASKING

PERSONAL  
PROTECTION  
EQUIPMENT

TECHNICAL  
INFORMATION

## MEDIUM MASKING TAPE

BETTER ++++

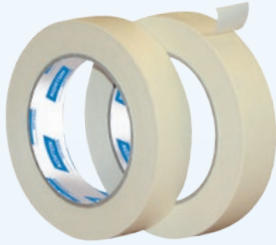

### FEATURES

- Support oven/dry cycles when temperature does not exceed 80°C
- Easy removal at 10°C
- Conforms to contours, irregular surfaces and shapes
- Compatible with most common paints & lacquers

### BENEFITS

- Resistance to high temperature
- No adhesive residue
- Good adhesion
- Removal without ripping

Applications:  
Car body repair,  
Painting and decorating

DIM WxL	PK QTY	ART. NO.
19mmx50m	48	69957394605
25mmx50m	36	69957394609
38mmx50m	24	69957394611
50mmx50m	24	69957394614

## GENERAL PURPOSE MASKING TAPE

GOOD +++

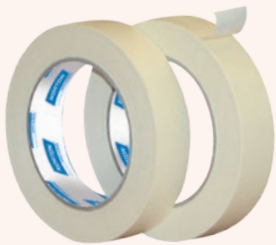

### FEATURES

- Optimum product performance up to 60°C
- Compatible with most common paints

### BENEFITS

- Ideal for paint masking
- Removal without ripping

Applications:  
Interior decoration,  
professional painters

DIM WxL	PK QTY	ART. NO.
19mmx50m	48	69957394617*
25mmx50m	36	69957394619*
38mmx50m	24	69957394623*
50mmx50m	24	69957394631*

\* Made-to-order



## FINE LINE TAPE

BEST +++++

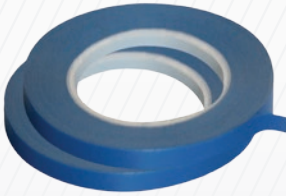

### FEATURES

- Used where there is resistance flakes
- Conforms to contours, irregular shapes and surfaces
- Performs in temperatures of up to 150°C for approx 30 minutes
- Easy to use
- One thickness for all

### BENEFITS

- Follows lines without wrinkling or tearing
- Leaves a sharp, clean separation line
- No adhesive residue
- Longer lasting
- Minimum build up
- Longer rolls compared to competitor products (55m)

Applications:  
Delicate paint work

DIM WxL	PK QTY	ART. NO.
3mmx55m	10	66261194993
6mmx55m	10	66261194994
9mmx55m	10	66261194995
12mmx55m	10	66261194996
19mmx55m	10	66261194997

## PREMIUM PERFORATED TRIM TAPE



### FEATURES

- Flexible, follows contours and curves
- Thick plastic strip fits all rubber trims
- Pre-perforated

### BENEFITS

- High quality adhesive
- No adhesive residue
- No scissors needed
- Individually packed
- No paper lines to remove

Applications:  
Rubber trims during spraying, body side moulding during spraying

DIM WxL	PK QTY	ART. NO.
50mmx10m	10	66261194743

**Dimensions Key:** DIM = Dimensions, W = Width, L = Length





## FOAM TAPE PREMIUM



Applications:  
Car body repair,  
preparation before  
spraying, all car  
door openings

### FEATURES

- One continuous length
- Recessed adhesive, no paint edge & no rubbing down
- Dimensions available:  
20mm x 50m

### BENEFITS

- One size fits all
- More absorbent
- Quick and easy protection of painted edges

DIM WxL	PK QTY	ART. NO.
20mmx50m	1	66254470746

## FOAM TAPE STANDARD

BETTER ++++



Applications:  
Car body repair,  
preparation before  
spraying, all car  
door openings

### FEATURES

- Recessed adhesive, no paint edge & no rubbing down
- Dimensions available:  
13mm x 50m, 19mm x 50m

### BENEFITS

- Quick and easy protection of painted edges

DIM WxL	PK QTY	ART. NO.
13mmx50m	1	66254470735
19mmx35m	1	66254470744



### SPEC CHECK

Thanks to its new features, the premium foam tape will ensure perfect job:

- Highly absorbent to avoid any leaking runs of paint.
- Flat and unique size to fit all gap adjustments and to allow to fix having the adhesive hidden.
- Consequently, when removed after spraying, there will be no defect and no need to rework upon removal.



## DOUBLE SIDED FOAM TAPE

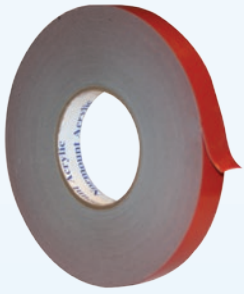

Applications:  
Marine, Car body repair,  
Truck, Train

### FEATURES

- High density foam coated with high strength acrylic
- Bonds medium to large mouldings and accessories

### BENEFITS

- Instant pressure sensitive bonding
- Does not absorb moisture
- Superior adhesion to plastics, metal, glass and paint
- Remains flexible at low/high temperature
- Conforms to irregular surfaces

DIM WxL	PK QTY	ART. NO.
6mmx18m	12	63642505620
12mmx18m	12	63642505621
22mmx18m	12	63642505622

## DOUBLE SIDED TAPE

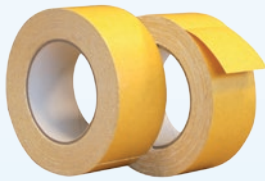

Applications: Polyester cloth for floor covering

### FEATURES

- Fits all types of covering

### BENEFITS

- Conforms to most surfaces
- High tack

DIM WxL	PK QTY	ART. NO.
50mmx10m	24	66261196541

## CLOTH TAPE

GOOD +++

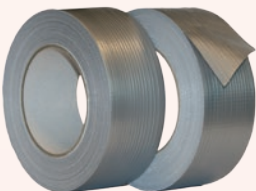

Applications:  
Multi-purpose industrial applications

### FEATURES

- Very high adhesion
- Water and heat resistant
- Individually packed

### BENEFITS

- Excellent immediate adhesion
- Edge protection and wrapping

DIM WxL	PK QTY	COLOUR	ART. NO.
50mmx50m	24	GREY	07660717720

**Dimensions Key:** DIM = Dimensions, W = Width, L = Length

## PLASTIFILM ULTRA

BEST +++++

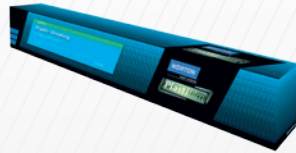

Plastifilm Ultra leaves no marks when used on damp cars, provides extra width and has a thicker film for better wear resistance and no tearing. Ultra resistance, absorption and protection.

### FEATURES

- High density polyethylene+
- Anti-paint-flaking treatment
- Heat resistant up to 110°C
- Made of recyclable material

### BENEFITS

- Anti-sweating, no marks if used on damp cars
- Water resistant, tough and tear resistant
- No bleed through of water based or solvent based products, excellent paint absorption
- Withstands spray booth temperatures

TYPE	DIM WxL	PK QTY	ART. NO.
ULTRA	4mx150m	1	63642504273
	5mx120m	1	63642504393
	6mx100m	1	63642504396

## PLASTIFILM PREMIUM

BETTER ++++



Higher resistance to temperature and wear & tear.

### FEATURES

- High density polyethylene
- Resistant temperatures up to 110°C and infra-red drying
- Static treatment
- 'Corona' treatment

### BENEFITS

- Resistant to both water-based and solvent-based paint
- Reduce process & cycle time
- Within working range of all spray booths
- One product for all applications
- Excellent adhesion to surface of the car
- Moulds to car shape immediately without tearing
- Work faster & more efficiently
- No dust contamination
- Prevents imprint marking on damp vehicles
- No humidity between film & coating

TYPE	DIM WxL	THICKNESS	PK QTY	ART. NO.
PREMIUM	4m x 150m	11 micron	1	66623341457
	5m x 120m	11 micron	1	66623341458

## PLASTIFILM STANDARD

GOOD +++



Good performance in all applications.

### FEATURES

- Transparent polyethylene
- Closed surface structure
- Can be compressed to minimum dimensions
- Long length film also available

### BENEFITS

- Excellent visibility
- Can be easily trimmed to size
- Prevents paint leaking through, avoiding rework
- Less waste
- Easy storage
- Lasts longer

TYPE	DIM WxL	PK QTY	ART. NO.
STANDARD	4mx150m	1	66623341451
	4mx300m	1	66623341454
	5mx120m	1	66623341455



### ACCESSORIES

DESCRIPTION	PK QTY	ART. NO.
Dispenser for Plastifilm	1	66623341459
Cutter for Plastifilm	50	07660708055

**Dimensions Key:** DIM = Dimensions, W = Width, L = Length



# 513-522 PERSONAL PROTECTION EQUIPMENT



514 Introduction  
516 Respiratory Masks

519 Single Use Gloves  
520 Glasses

522 Overalls



# INTRODUCTION

From Norton, the world's leading abrasive brand, comes a new range of personal protection equipment designed to provide the highest standard of protection in the workplace. Through understanding our customers needs and requirements for a safer working environment, we are able to deliver a valuable, effective solution for applications in multiple industries.



## STANDARD SAFETY REGULATIONS

All products in the range adhere to the most stringent European directives and regulations. Our responsibility to our customers, particularly in the area of safety and comfort is taken very seriously. Products are designed and produced to the most rigorous quality standards to guarantee optimum personal safety and user comfort. In addition, Norton prides itself on having an environmentally friendly approach to caring for the environment, which is a fundamental part of corporate Saint-Gobain culture.

## AN OVERVIEW OF THE RANGE

- Respiratory Masks (various protection levels)
- Premium safety glasses
- Standard safety glasses
- Latex single use gloves
- Nitrile single use gloves
- Painting overalls
- Bodyshop overalls



## STANDARD SAFETY REGULATIONS

Protection against major hazards: Respiratory protective devices are PPE Class 3:

- The hazard may be serious, irreversible or fatal
- The design is complex as defined by the directive
- Certification is provided by an approved body with a CE-type examination combined with a quality control system for production
- Marking is regulated, with additional markings according to the standard in force at the time of the product's certification

### NORTON UPHOLDS THE FOLLOWING EUROPEAN DIRECTIVES FOR RESPIRATORY MASKS:



- Directive 89/656/CEE of 30 November 1989: on the use of PPE by workers. It stipulates the employers' obligations
- The PPE required for work must be provided free of charge
- PPE must comply with the legal provisions in force
- The employer must have, at its disposal, the information needed for proper use of the product. The rules and conditions of use must be defined
- The user must be informed, and training provided
- Directive 89/686/CEE of 21 December 1989: on the design, market entry, free circulation of PPE within the European Union. This Directive has evolved and been modified by 95/58/CEE
- The essential requirements to be met by PPE in order to be put on the European market
- The specific texts provide a classification with regard to hazards

### SINGLE USE RESPIRATORS AND DUAL CARTRIDGE RESPIRATOR MASK

#### DISPOSABLE MASK

**EN149:** Filtering half-masks (single use) for protection against particulates. There are three protection classes: FFP1, FFP2, FFP3.

#### SEMI DISPOSABLE MASK

**EN405:** Filtering masks with valves for protection against gases or against gases and particulates.

#### GASES VAPOURS: FOR EACH TYPE OF CONTAMINANT THERE IS A DEDICATED FILTER

**A:** Gases and organic vapours, including boiling points above 65°C e.g.: Solvents, hydrocarbons, etc.

**AX:** Gases and organic vapours, including boiling points below 65°C.

**P:** Particulates, dust.



## STANDARDS AND LEGISLATION FOR GLASSES

Directive 89/686/EEC (Design) describes the essential requirements to be met in order to sell protective glasses on the European market.

PPE from the European Union must bear a marking testifying to its compliance with Directive 89/686/EEC. All our glasses complies with Directive 89/686/EEC and EN 166 which describes "Technical Performance standards". Our premium glasses complies with the EN 175 which describes "equipment for eye and face protection during welding and allied process".

The "CE" marking appears on the smallest packaging unit.

# RESPIRATORY MASKS

All Norton respiratory masks offer state of the art design, protection and comfort. The Dual Cartridge mask offers improved vision, adjustable head straps, and a form guard to maintain mask shape and cleanliness. All Norton masks protect against dust and potentially harmful gasses found in the automotive refinish, marine, aerospace, metal work and wood work markets.



## DUAL CARTRIDGE RESPIRATOR MASK MODEL 2016



### FEATURES

- Soft, non-allergenic material
- Patented hygienic form guard
- Low profile cartridge
- Cradle suspension and adjustable head straps

### BENEFITS

- Smooth and comfortable on the face
- Maintain shape and cleanliness after use
- Improved vision
- Proper and comfortable fit

MASK (mm)	ELASTIC LxTxW (mm)	PROTECTION LEVEL	QTY PER BOX	SELLING UNIT	ART NO.
Inferior part Width 112 Height 134	605x1,5x12	A2P2	12	12	66254482016

EN405:2001+A1:2009



## USAGE ADVICE

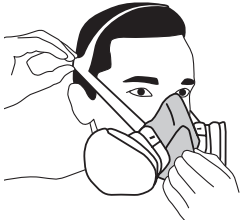

Place the respirator over the mouth and nose, then pull the head harness over the crown of the head.

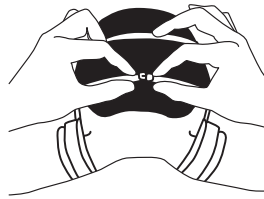

Attach the bottom straps behind the neck.



Tighten top strap by pulling on ends to obtain a secure and comfortable fit. Tighten bottom straps by pulling on ends or loosen by pushing out on buckle tab.



Check respirators each time you enter a contaminated area.

## PARTICULATE FILTER PAD REPLACEMENT MODEL 2017



Use with the Dual Cartridge mask (model 2016) to protect against dust and gases. Filter replacement pads are low maintenance and can be frequently replaced to prevent replacing the mask itself.

PROTECTION LEVEL	QTY PER BOX	SELLING UNIT	ART NO.
P2	12	12	66254482017

EN405:2001+A1:2009



## RESPIRATORY MASK WITH VALVE MODEL 2020



Single use protection mask FFP2D SL, protects against low toxicity solid and liquid aerosols in concentration of up to 12xOEL. Protects against calcium carbonate, ferrous metal, hardwood, glass fibres, plastic, quartz, copper and aluminium. Not for use when oxygen concentration is less than 17% vol.

### FEATURES

- Expiration valve
- Polypropylene filter media
- Wire moulding

### BENEFITS

- Allows easier breathing
- Maximum protection every time
- High filtration efficiency
- Shapes to the form of the nose

MASK (mm)	NOSE PIECE LxTxW (mm)	VALVE DxH (mm)	ELASTIC LxTxW (mm)	PROTECTION LEVEL	QTY PER BOX	SELLING UNIT	ART NO.
Inferior part Width 85 Superior part Width 200 Height 87	90x9x0,5	41x11	560x0,7x6	FFP2	20	20	66254482020

EN149:2001+A1:2009



# SINGLE USE GLOVES

Nitrile and latex gloves are designed for handling chemical and non-chemical compounds in the automotive refinish, marine, aerospace, metal work and wood work markets.

## CERTIFICATIONS

- Certification ISO 9001:2000 + ISO 13485:2003
- Conformity to technical standards EN 455-1 (pinholes detection) + EN 455-2 (physical properties) + EN 455-3 (biological evaluation) + Pr EN 455-4 (shelf life determination)
- Mark according to European Directive 93/42/EEC



## NON-STERILE NITRILE GLOVES MODEL 2022

Disposable gloves, designed for handling chemical compounds, powder-free and resistant to disinfectants.



### FEATURES

- Latex free, synthetic nitrile rubber
- Ambidextrous shape

### BENEFITS

- Prevents skin irritation
- Fits all hand sizes

SIZE	QTY PER BOX	SELLING UNIT	ART NO.
Medium	100	100	66623398849
Large	100	100	66254482022
Extra Large	100	100	66623398850

## NON-STERILE LATEX GLOVES MODEL 2023

Disposable gloves for handling non-chemical compounds, powder-free and resistant to disinfectants. Minimum protection level 50µg/g.



### FEATURES

- Natural rubber latex
- Ambidextrous

### BENEFITS

- Prevents skin irritation
- Fits all hand sizes

SIZE	QTY PER BOX	SELLING UNIT	ART NO.
Medium	100	100	66623398847
Large	100	100	66254482023
Extra Large	100	100	66623398848



# GLASSES

Providing eye protection for metal, welding, cutting, grinding and sanding applications. Adjustable hinges on Premium glasses allow for comfortable use with respiratory masks.

## UNDERSTANDING LENS MARKING

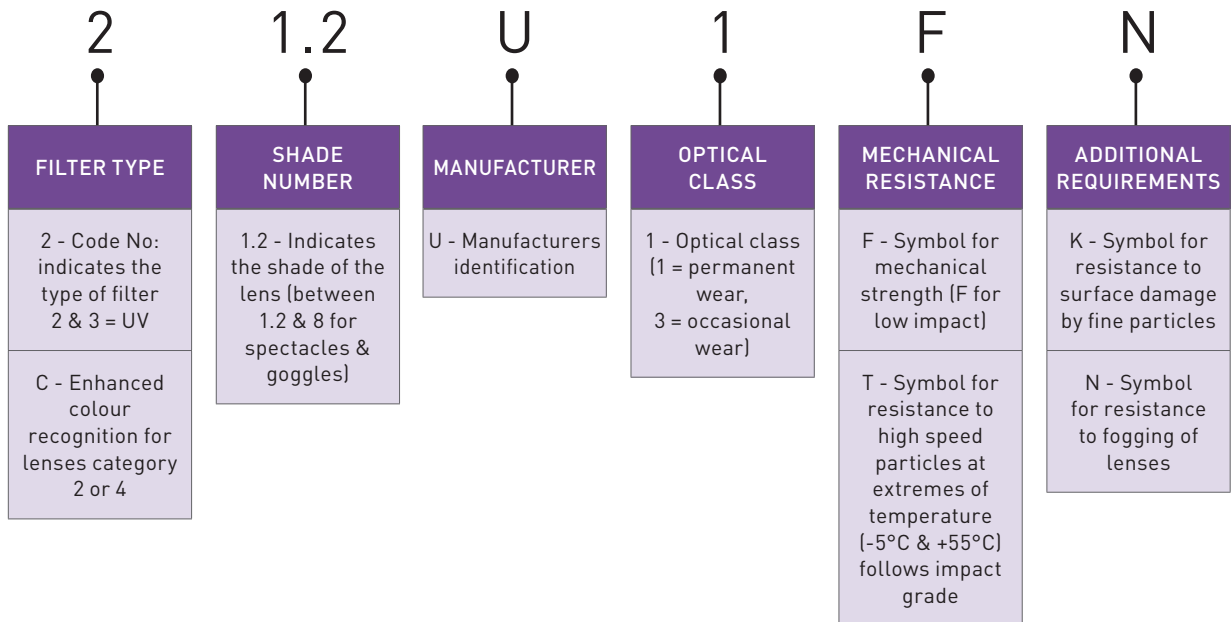
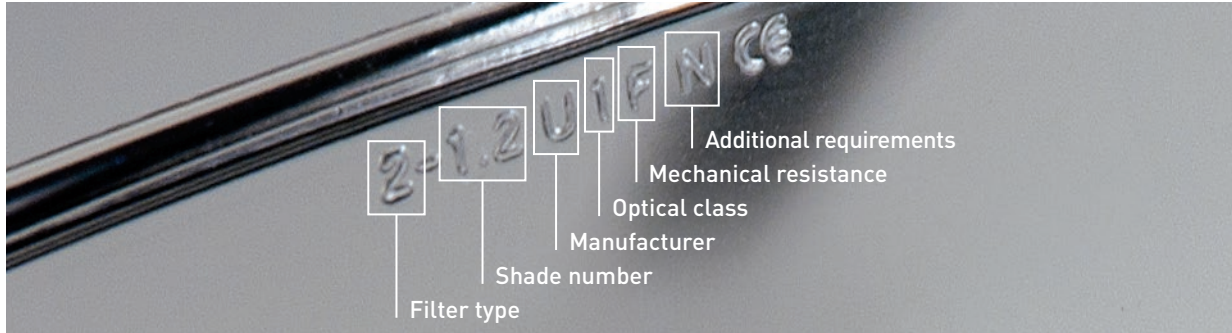

## UNDERSTANDING FRAME MARKING

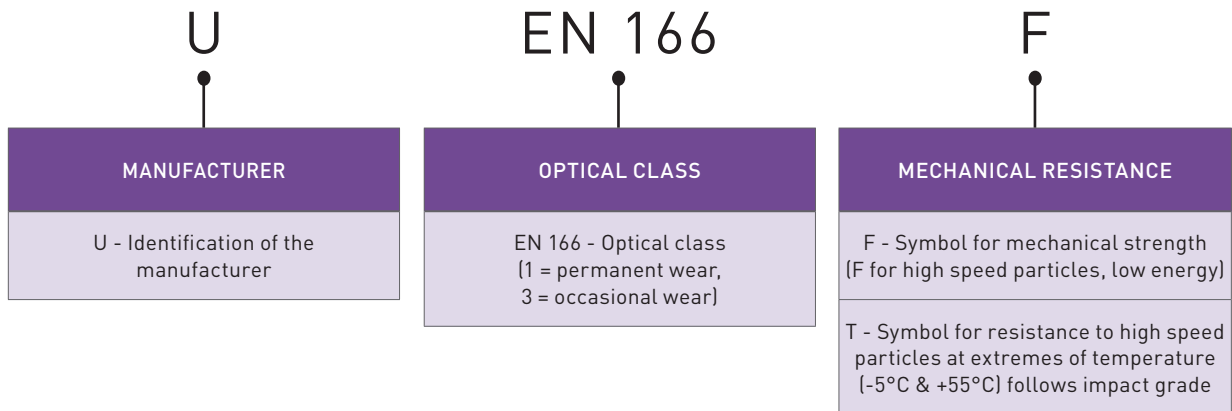

## SAFETY GLASSES: PREMIUM MODEL 2024



Provides optimum eye protection during welding and metal applications

### FEATURES

- Adjustable hinges
- Frame & lens marking
- Hydrophobic coated lenses

### BENEFITS

- Comfortable use with respiratory masks
- Quality & safety assurance

QTY PER BAG	SELLING UNIT	ART NO.
1	10	66254482024

EN 175

## SAFETY GLASSES: STANDARD MODEL 2025



For general purpose applications

### FEATURES

- Frame & lens marking

### BENEFITS

- Quality & safety assurance

QTY PER BAG	SELLING UNIT	ART NO.
1	10	66254482025

EN 166



# OVERALLS

Protect clothes from paint, dust and damage with Norton overalls. Overalls are washable and reusable and available in medium, large and extra large sizes.



## PAINTING OVERALLS



### FEATURES

- Polyester material
- Anti-static

### BENEFITS

- Breathable
- Washable and reusable
- Easy to wear

MODEL	SIZE	QTY PER BOX	ART NO.
8976	Medium	10	66254428976
8977	Large	10	66254428977
8978	Extra Large	10	66254428978

## BODY SHOP OVERALLS



### FEATURES

- Polycotton material

### BENEFITS

- Breathable
- Washable & reusable

MODEL	SIZE	QTY PER BOX	ART NO.
8314	Medium	5	07660718314
8315	Large	5	07660718315
8316	Extra Large	5	07660718316

523-574

# TECHNICAL INFORMATION



- 524 Cutting-Off & Grinding Wheels
- Technical Information
  - Troubleshooting
  - Safety Advice

- 532 Coated Abrasives
- Technical Information
  - Safety Advice

- 543 Beartex
- Product Selection - by Machine
  - Product Selection - by Application

- 553 Bonded Abrasives
- Technical Information
  - Troubleshooting
  - Safety Advice



- 566 Super Abrasives
- Technical Information
  - Troubleshooting

- 571 Diamond Blades
- Technical Information
  - Troubleshooting
  - Safety Advice

# CUTTING-OFF & GRINDING WHEELS

## TECHNICAL INFORMATION

### SHAPE SPECIFICATION SYSTEM

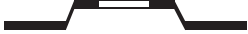
BF 27	BF 29	BF 41	BF 42
			
DEPRESSED CENTRE GRINDING WHEELS	DEPRESSED CENTRE GRINDING WHEELS	FLAT CUTTING-OFF WHEELS	DEPRESSED CENTRE CUTTING-OFF WHEELS
Available in diameters 76-230mm for hand-held machines.	Available in diameters 115mm & 125mm for hand-held machines.	Available in diameters 40-400mm for hand-held machines & 250-400mm for stationary machines.	Available in diameters 76-230mm for hand-held machines.
Application: grinding	Application: grinding	Application: cutting-off	Application: cutting-off

## RECOMMENDED PRACTICE

### PORTABLE GRINDERS

#### GRINDING ROUGH WORK

- Do not use a cutting-off wheel for snagging
- Do not work with the side of a wheel, you will cut the reinforcing cloths
- Work at an angle of 10 to 30° with a longitudinal action

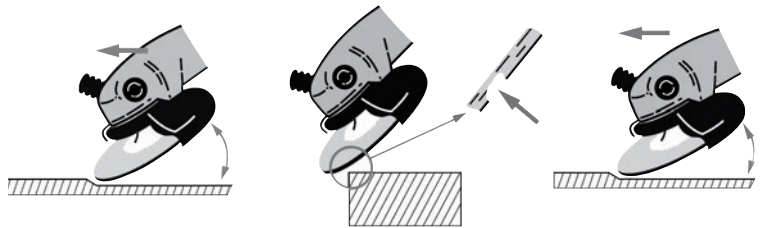

#### GRINDING FINISHING WORK

- Angle of work 15°
- Rotary action



#### CUTTING-OFF

- Arrange the workpiece so that a uniform section can be cut

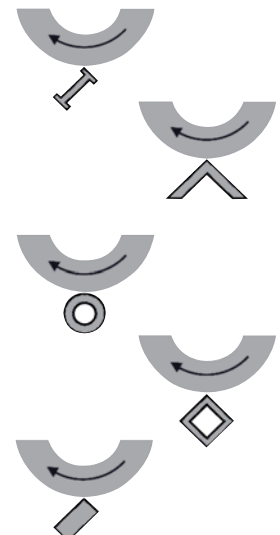
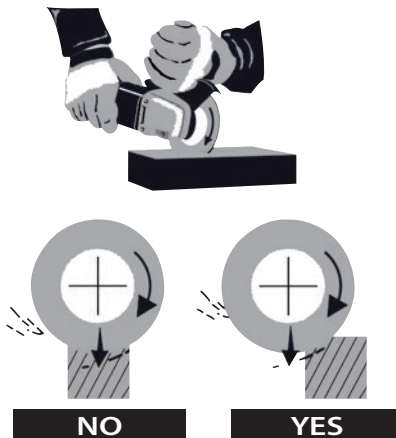
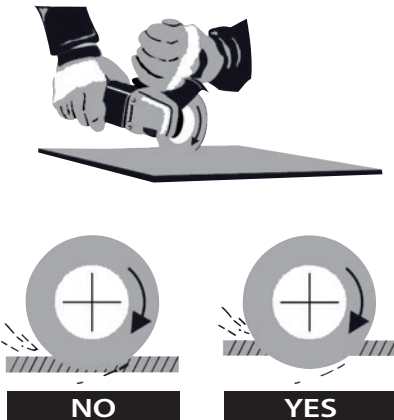



## FIXED MACHINE

### DOWNSTROKE HEADS

- Lay out the shape parts in order to have a constant section
- Avoid any wedging of the grinding wheel
- Make sure the wheel is cleared

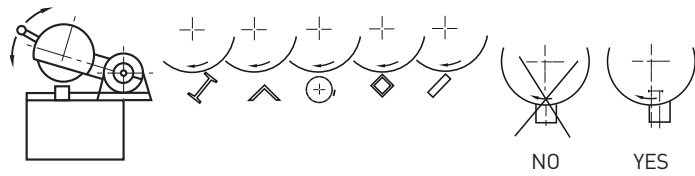

### AUTOMATIC FEED

- In the case of thick parts, use the reciprocating motion of the carriage

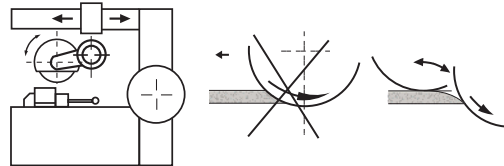

### OSCILLATING HEADS

#### OPERATING MODE

1. Oscillating
2. Cutting-off

Do not use this type of machine with a downstroke action

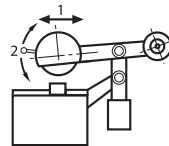

## METAL RING WITH VALIDITY DATE

V = VALIDITY DATE (PRODUCTION QUARTER + 3 YEAR)



V01	V04	V07	V10
1st quarter	2nd quarter	3rd quarter	4th quarter

#### EXAMPLE:

V04/2019 indicates production in the 2nd quarter of 2016 and advised usage before the 2nd quarter of 2019



## PERSONAL PROTECTION

Safety goggles, ear defenders, safety gloves, dust masks and, if conditions are severe, additional face protection. Leather aprons and safety shoes must be worn.



Mouth  
Protection



Wear  
Gloves



Eye  
Protection



Ear  
Protection



Read  
Instructions



Damaged  
Wheel -  
Do not use



Dry



Wet



## GENERAL PRECAUTIONS

Safety instructions provided by the machine manufacturers must be followed. Where fitted, all guards, covers and hoods must be in place on the machine during grinding, and should not be modified in any way. Abrasives should not be used near inflammable material or in an environment where there is a risk of explosion.

Sparks should be directed away from the face and body, if possible towards the floor. Dust extraction equipment must be used whenever it is available. The instructions for use given by the abrasive manufacturer must be followed e.g. 'Not to be used without a support', or 'Not to be used for wet grinding'. The workpiece must be firmly fixed before grinding starts. Check all abrasives visually before use and make certain that the product is suitable for the application. No modifications should be made to abrasive products after delivery.

When using a portable grinder always switch it off and allow the spindle to stop completely before putting the tool down. Wet grinding should only be carried out on machines designed for this purpose and with abrasives designated as suitable for this type of operation.

## OPERATING SPEEDS

Norton products are designed and tested for certain applications and operating speeds. Choose a wheel suitable for the application material. Suitable materials are indicated on the wheel label. Before mounting the grinding or cutting-off wheel on the machine, ensure that the operating speed of the machine does not exceed the maximum operating speed as it is marked on the product.

WHEEL DIAMETER (mm)	SPEED CONVERSION FOLLOWING EN 12413								
	MAXIMUM OPERATING SPEED (RPM)								
	35	40	50	63	80	100	125	140	160
6	112000	128000	160000	201000					
8	84000	95500	120000	150500	191000				
10	67000	76500	95500	120500	153000	191000			
13	51500	58800	73500	92600	118000	147000	184000	206000	
16	41800	47800	59700	75200	95500	120000	150000	168000	191000
20	33500	38200	47800	60200	76500	95500	120000	134000	153000
25	26800	30600	38200	48200	61200	76500	95500	107000	123000
32	20900	23900	30000	37600	48000	60000	75000	84000	95500
40	16750	19100	23900	30100	38200	47200	59700	67000	76500
50/51	13400	15300	19100	24100	30600	38200	47750	53500	61200
63/65	10650	12150	15200	19100	24300	30250	37900	42500	48500
76	8800	10100	12600	15850	20150	25150	31450	35200	40250
80	8400	9550	12000	15100	19100	23900	29850	33500	38200
85	7900	9000	11250	14200	18000	22500	28100	31500	36000
100/102	6700	7650	9550	12100	15300	19100	23900	26800	30600
115	5850	6650	8350	10500	13300	16650	20800	23250	26600
125	5350	6150	7650	9650	12250	15300	19100	21400	24500
150/152	4500	5100	6400	8050	10200	12700	16000	17850	20400
180	3750	4250	5350	6700	8500	10650	13300	14900	17000
200	3350	3850	4800	6050	7650	9550	11950	13400	15300
230	2950	3350	4200	5250	6650	8350	10400	11650	13300
250/254	2700	3100	3850	4850	6150	7650	9550	10700	12250
300/305	2250	2550	3200	4050	5100	6400	8000	8950	10200
350/356	1950	2200	2750	3450	4400	5500	6850	7650	8750
400/406	1700	1950	2400	3050	3850	4800	6000	6700	7650
450/457	1500	1700	2150	2700	3400	4250	5350	5950	6800
500/508	1350	1550	1950	2450	3100	3850	4800	5350	6150
600/610	1150	1300	1600	2050	2550	3200	4000	4500	5100
750/762	895	1050	1300	1650	2050	2550	3200	3600	4100
800/813	840	960	1200	1550	1950	2400	3000	3350	3850
900/914	750	850	1100	1350	1700	2150	2700	3000	3400
1000/1020	670	765	960	1250	1550	1950	2400	2700	3100

## TROUBLESHOOTING

### CUTTING-OFF WHEELS

#### WHEEL DOES NOT CUT

Cause	In case of blue cutting: wheel too hard or too thick
Solution	Use softer or Norton Thin Cut wheels, check peripheral speed
Cause	Peripheral speed too low
Solution	Increase rpm up to max. (80m/sec)

#### EXCESSIVE WEAR

Cause	In case of white cutting edge: wheel too soft
Solution	Use harder wheel
Cause	Operating speed too low
Solution	Increase rpm up to max (80m/sec)
Cause	Decrease of rpm during cutting
Solution	Use machine with more power, reduce pressure on the machine

#### CRUMBLED WHEEL EDGE

Cause	Cutting-off wheel used for grinding operations
Solution	Use a grinding wheel for grinding operations
Cause	Workpiece is moving
Solution	Clamp the workpiece properly
Cause	Too much side-pressure
Solution	Add only the radial pressure to the wheel

#### ARBOR HOLE OR CENTRE BREAK OUT

Cause	Wheel sticks in the workpiece/material
Solution	Use more radial pressure & swing the wheel forwards and backwards
Cause	Cutting-off wheel used for grinding operations
Solution	Use a grinding wheel for grinding operations
Cause	Too much side pressure
Solution	Add only the radial pressure to the wheel
Cause	Different diameter top/bottom flange
Solution	Use flanges with the same diameter

## GRINDING WHEELS

### WHEEL DOES NOT CUT

Cause	Wheel too hard, wheelglazing
Solution	Use softer wheel
Cause	Not enough pressure
Solution	Increase pressure
Cause	Machine power too low
Solution	Use machine with more power
Cause	Loading & wheelglazing (non-ferrous)
Solution	Use Norton Alu wheels which counteract loading & wheelglazing

### EXCESSIVE WHEELWEAR

Cause	Wheel too soft
Solution	Use harder wheel
Cause	Too much pressure
Solution	Reduce pressure, let the wheel do the grinding
Cause	Decrease of peripheral speed
Solution	Use machine with more power, reduce pressure on the machine
Cause	Too low peripheral speed
Solution	Max. 80m/sec is optimum speed

### CRUMBLED WHEEL EDGE

Cause	Grinding angle too flat
Solution	Change angle to 30 - 40°
Cause	Workpiece is moving
Solution	Clamp the workpiece properly
Cause	Too much pressure
Solution	Reduce pressure, let the wheel do the grinding

### CRACKS ON THE BOTTOM OF THE WHEEL

Cause	Contact area too large
Solution	Reduce contact area
Cause	Too much pressure
Solution	Reduce pressure, let the wheel do the grinding

### UNBALANCE

Cause	Dirty flanges
Solution	Clean flanges
Cause	Wheel mounting insecure
Solution	Tighten flanges
Cause	Flanges with different diameter
Solution	Replace flanges

## SAFETY ADVICE

### D0s

✓	D0	Always handle & store wheels carefully. Cutting-off wheels should be stacked horizontally & flat, preferably on a steel base plate. Depressed centre wheels should be placed on top of each other or stored in the original packaging
✓	D0	Always visually inspect all wheels before mounting for possible damage in transit
✓	D0	Always use a safety guard & ensure that it is correctly positioned & securely fitted. It should cover at least one half of the wheel & protect the operator in the unlikely event of a wheel breakage. <b>NON-REINFORCED CUTTING-OFF WHEELS SHOULD ONLY BE USED ON FIXED MACHINES &amp; SHOULD BE CORRECTLY GUARDED.</b>
✓	D0	Always switch 'OFF' the power at supply source &/or remove the plug from the socket before changing the wheel
✓	D0	Always ensure that the spindle speed of the machine does not exceed the operating speed marked on the wheel
✓	D0	Always use the correct wheel mounting flanges & ensure that they are undamaged, clean & free from burrs
✓	D0	SEE EN 12413
✓	D0	Allow newly mounted wheels to run at operating speed, with the guard in place, for a reasonable time before cutting or grinding
✓	D0	Always wear EYE PROTECTION
✓	D0	Always wear appropriate safety clothing such as DUST MASK, GLOVES, EAR PROTECTION, OVERALLS & SAFETY SHOES
✓	D0	Always have machine speeds checked regularly, especially after maintenance or repair. Machines fitted with speed control devices (Governors), must be properly maintained at all times
✓	D0	Check tension of driving belts, where fitted, on a regular basis. Belts must be kept tight to ensure full power transmission.
✓	D0	Always secure the workpiece firmly while it is being cut or ground
✓	D0	Put portable machines in suitable cradles, when not being used, to avoid damage to the wheel
✓	D0	Always use a portable machine in a comfortable position, where the workpiece is well balanced & the machine is well supported
✓	D0	Grind at an angle above 30 degrees to the workpiece with a depressed centre grinding wheel
✓	D0	Keep the working area around cutting & grinding operations clear. It is very dangerous if an operator trips & falls with an operating machine in his hands

## DON'Ts

X	DON'T	Handle wheels roughly
X	DON'T	Use non-reinforced cutting-off wheels on portable machines
X	DON'T	Store wheels in a damp atmosphere or in extreme temperatures
X	DON'T	Mount a damaged wheel
X	DON'T	Tighten the mounting nut or locking flange excessively. To do so can distort the flanges
X	DON'T	Force a wheel onto a machine spindle
X	DON'T	Use mounting flanges which are incorrect, damaged, dirty or burred
X	DON'T	Use blotters with depressed centre wheels less than or equal to 406mm (EN 12413)
X	DON'T	Use a machine which is not in good mechanical condition
X	DON'T	Use a machine without a wheel guard
X	DON'T	Use wheels without proper ventilation or dust protection equipment
X	DON'T	Apply side pressure to cutting-off wheels. You should not bend the wheel
X	DON'T	Stop the wheel by applying pressure to the periphery or face. Always switch the machine off & allow the wheel to stop revolving
X	DON'T	Allow the wheel to be trapped or pinched in the cut
X	DON'T	Apply excessive pressure onto the wheel so that the driving motor slows down
X	DON'T	Grind on the side of cutting-off wheels or depressed centre wheels below 4,0mm thickness
X	DON'T	Drop or lower a portable machine by the cable or airline onto the floor. A wheel can be easily cracked, if it is put down hard, by the weight of the machine. This is a common cause of wheel breakage
X	DON'T	Grind with a depressed centre grinding wheel at an angle below 30 degrees to the workpiece
X	DON'T	Use a machine in a position where you do not have full control of the machine & you are not well balanced



# COATED ABRASIVES

## TECHNICAL INFORMATION

### WHAT IS A COATED ABRASIVE?

Modern coated abrasives are the product of an extremely technical process developed through many years of research and development. They remain, however, a product composed of three basic elements: a flexible or semi-rigid backing to which abrasive grains are bonded by an adhesive.

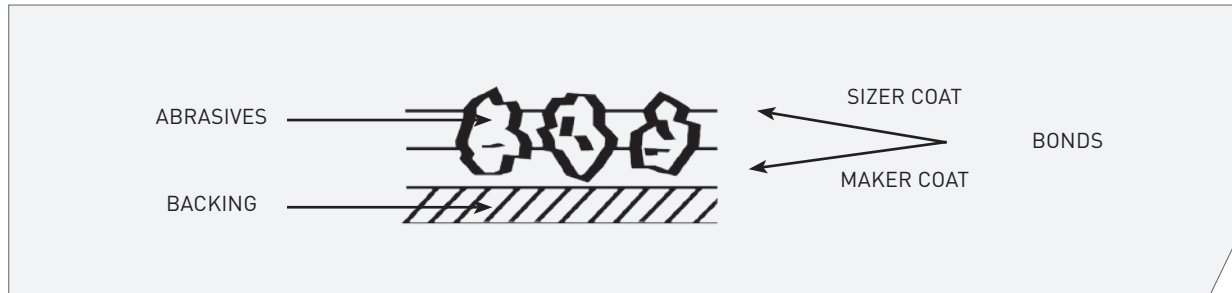

### ABRASIVE TYPES

The ideal abrasive grain offers maximum resistance to point wear, yet fractures before serious dulling occurs, thereby satisfying both stock removal and finishing requirements.

#### SYNTHETIC ABRASIVES

- Aluminium oxide is tough and well adapted to grinding high tensile materials, such as carbon steel, alloy steels, tough bronze and hard woods. Wherever toughness (ability to resist fracturing) is the main consideration, aluminium oxide outperforms all other coated abrasive grains
- Silicon carbide is the hardest and sharpest of the minerals used in coated abrasives. Its hardness and sharpness make it the ideal abrasive for sanding non-ferrous metals (aluminium, brass, bronze, magnesium, titanium, etc.), rubber, glass, plastics, fibrous woods, enamel and other relatively soft materials. Silicon carbide is superior to any other abrasive in its ability to penetrate and cut faster under light pressure
- Zirconia alumina has a unique self-sharpening characteristic which gives it long life on rugged stock removal operations. Zirconia alumina is well suited for heavy grinding of metals and planing of wood, because the controlled fracturing of the grain continuously produces sharp, new abrading points
- Ceramic aluminium oxide is a long-lasting, tough, dense abrasive due to its micro structure. The extremely small micron size particles break off during grinding, producing multiple new cutting edges. As it stays sharp, especially when used in medium and high pressure operations, it cuts at a higher rate than other abrasives. Recommended for use on forged and carbon steels, high nickel and cobalt alloys

#### NATURAL ABRASIVES

- Emery is a natural composite of corundum and iron oxide. The particles are blocky in shape and tend to cut slowly, thereby producing a polishing action on the material being abraded. Used for general maintenance and polishing of metals and in very fine grits for highly technical polishing, such as preparing metallurgical specimens requiring very close tolerances. Emery products are black in colour

### ABRASIVE GRAIN DISTRIBUTION

There are two types of abrasive grain coverage on the backing:

- Openly spaced distribution where between 30% and 60% of the backing is covered leaving large spaces between each abrasive grain. It is used in operations where the grinding swarf would otherwise 'load' or clog the surface, reducing cutting efficiency and shortening the coated abrasive life
- Closely packed grain distribution is where the grain completely covers the backing. The greater number of abrading points in a given area leads to faster stock removal. It is recommended where loading is not a problem and where smoother surface finishes are desired

## ABRASIVE GRAIN SIZE

After the crude abrasives have been crushed, the grains are separated (graded) into standard particle sizes using screens carefully made from silk threads of exact size and number per square inch to ensure extreme accuracy. The grit number (mesh number) appearing on the coated abrasive backing represents the number of openings per linear inch in the final screen. Grits 240 and finer, called flours, are graded by hydraulic separators, air classifiers and levigating tanks.

The European standard of grit sizes is the FEPA grading system. All FEPA grit sizes are preceded with the letter 'P', i.e. P180 etc.

In the USA a different grading system called CAMI is used. This chart provides a comparison between FEPA and CAMI grades and also shows average particle sizes in microns and inches.

Additionally, some products produced for the woodworking and floor sanding markets are identified with a 'grit symbol'. Although use of this symbol is infrequent, the backing of these products contain both the mesh number and the grit symbol.

PARTICLE SIZE IN INCHES	PARTICLE SIZE IN MICRON	ALUMINIUM OXIDE, GARNET, SILICON CARBIDE, ZIRCONIA ALUMINA			EMERY		GLASS PAPER
		GRADING SYSTEMS		COMP. GRIT SYMBOL	POLISHING PAPER	CLOTH	
		CAMI	FEPA				
,0000118	0,3	-	-	-	-	-	-
,0000197	0,5	-	-	-	-	-	-
,0000394	1,0	-	-	-	-	-	-
,0000787	2,0	-	-	-	-	-	-
,000118	3,0	-	-	-	-	-	-
,000158	4,0	-	-	-	-	-	-
,000197	5,0	-	-	-	-	-	-
,000236	6,0	-	-	-	-	-	-
,00026	6,5	1200	-	-	-	-	-
,00035	9,0	-	-	-	-	-	-
,00036	9,2	1000	-	-	-	-	-
,00047	12,0	-	-	-	-	-	-
,00048	12,2	800	-	-	4/0	-	-
,00059	15,0	-	-	-	-	-	-
,00060	15,3	-	P1200	-	-	-	-
,00062	16,0	600	-	-	3/0	-	-
,00071	18,3	-	P1000	-	-	-	-
,00077	19,7	500	-	-	2/0	-	-
,00079	20,0	-	-	-	-	-	-
,00085	21,8	-	P800	-	-	-	-
,00092	23,6	400	-	10/0	0	-	-
,00098	25,0	-	-	-	-	-	-
,00100	27,75	-	P600	-	-	-	-
,00112	28,8	360	-	-	-	-	-
,00118	30,0	-	-	-	-	-	-
,00118	30,2	-	P500	-	-	-	-
,00137	35,0	-	P400	-	-	-	-
,00140	36,0	320	-	9/0	-	-	-
,001575	40,0	-	-	-	-	-	-
,00158	40,5	-	P360	-	-	-	-
,00172	44,0	280	-	8/0	1	-	-
,00177	45,0	-	-	-	-	-	-
,00180	46,2	-	P320	-	-	-	-
,00197	50,0	-	-	-	-	-	-

## ABRASIVE GRAIN SIZE

PARTICLE SIZE IN INCHES	PARTICLE SIZE IN MICRON	ALUMINIUM OXIDE, GARNET, SILICON CARBIDE, ZIRCONIA ALUMINA			EMERY		GLASS PAPER
		GRADING SYSTEMS		COMP. GRIT SYMBOL	POLISHING PAPER	CLOTH	
		CAMI	FEPA				
,00204	52,5	-	P280	-	-	-	-
,00209	53,5	240	-	7/0	-	-	-
,00217	55,0	-	-	-	-	-	-
,00228	58,5	-	P240	-	-	-	-
,0023	60,0	-	-	-	-	-	-
,00254	60,5	-	P220	-	-	-	-
,00257	66,0	220	-	6/0	2	-	-
,00304	78,0	180	P180	5/0	3	-	00
,00363	93,0	150	-	4/0	-	Fine	-
,00378	97,0	-	P150	-	-	-	0
,00452	116,0	120	-	3/0	-	-	-
,00495	127,0	-	P120	-	-	-	1
,00550	141,0	100	-	2/0	-	Medium	-
,00608	156,0	-	P100	-	-	-	1½
,00749	192,0	80	-	0	-	-	-
,00768	197,0	-	P80	-	-	-	F2
,01014	260,0	-	P60	-	-	-	M2
,01045	268,0	60	-	1/2	-	Coarse	-
,01271	326,0	-	P50	-	-	-	S2
,01369	351,0	50	-	1	-	-	-
,01601	412,0	-	P40	-	-	-	2½
,01699	428,0	40	-	-1½	-	-	-
,02044	524,0	-	P36	-	-	-	36
,02087	535,0	36	-	2	-	Extra coarse	-
,02426	622,2	-	P30	-	-	-	-
,02488	638,0	30	-	2½	-	-	-
,02789	715,0	24	-	3	-	-	-
,02886	740,0	-	P24	-	-	-	-
,03530	905,0	20	-	3½	-	-	-
,03838	984,0	-	P20	-	-	-	-
,05148	1320,0	16	-	4	-	-	-
,05164	1324,0	-	P16	-	-	-	-
,06880	1764,0	-	P12	-	-	-	-
,07184	1842,0	12	-	4½	-	-	-

## NARROW BELTS & WIDE BELTS

The results achieved when sanding with belts depends on several factors including:

- The machine condition & available horsepower
- The belt speed
- The grinding pressure
- The contact wheel
- The choice of the belt in relation to the shape of the part & material type
- The use of coolant (when machine & belt allows)

### BELT SPEED

The speed of the belt has a direct relationship with its cut rate, as well as the amount of heat generated, the surface finish achieved, and the stress on abrasive grain. Some abrasives like zirconia alumina and ceramic support much higher stresses because they have a better resistance to uncontrolled fracture. Some materials are more sensitive to heat generation. The chart below gives the recommended speed range according to material.

### RECOMMENDED GRINDING BELT SPEED

Heat sensitive materials, plastics, etc.	5-15m/s	Stainless steel, high-speed steel & tool steel	20-30m/s
Sintered metals & carbides	8-15m/s	Grey cast iron & cast steel	30-40m/s
Titanium & similar alloys	8-15m/s	Carbon steel	30-40m/s
Glass, porcelain & special steel	8-15m/s	Brass, copper, zinc, bronze & tin	25-35m/s
Heat-resistant plastics	20-30m/s	Aluminium & light metal	20-35m/s
Wood	15-30m/s	Varnish	10-15m/s

### GRINDING PRESSURE

The amount of grinding pressure depends on:

- The force used
- The size of the contact area between the belt & the workpiece
- The backing on which the belt runs (generally a contact wheel)

Higher pressure increases the cut rate and the amount of heat generated increases the stress on the individual abrasive grain (a minimum stress is necessary to achieve a controlled fracture of the abrasive grain), and generally generates a rougher finish.

## CONTACT WHEELS

Many machines use contact wheels as a backing for belts. Contact wheels are generally covered with rubber, polyurethane, steel, rubber foam, felt, or compressed canvas, and are classified from soft to hard, with or without serrations. Using a different type of contact wheel has a direct effect on the end results.

- Harder contact wheels provide a higher cut rate, a rougher surface finish & generate a much more uniform surface than softer contact wheels. They are used with stiff belts for a faster cut
- Softer contact wheels provide lower cut rates, a better surface finish & follow the contours of the part. They are generally used for finishing contoured parts or for generating slightly rounded surfaces. They are much less hard wearing on the belt & its joint

The design of the contact wheel will also have an effect on the contact area, which in turn affects grinding pressure.

- Contact wheels with a larger diameter act softer & should generally be used on larger surfaces
- Serrated contact wheels act harder but should generally be used on smaller surfaces

## CONTACT WHEEL TYPES

HARD ←————→ SOFT

Aggressiveness increases as angle increases

Contact surface decreases as lands decrease giving a more aggressive, harder wheel

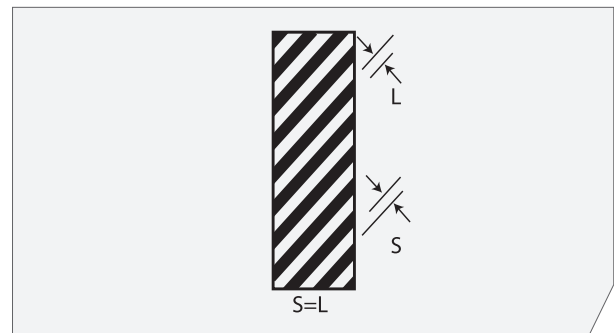
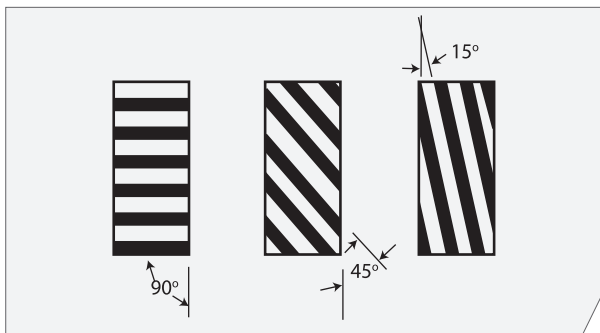

## JOINT TYPES

Belts are made with a standard joint design best adapted to the product and its main application:

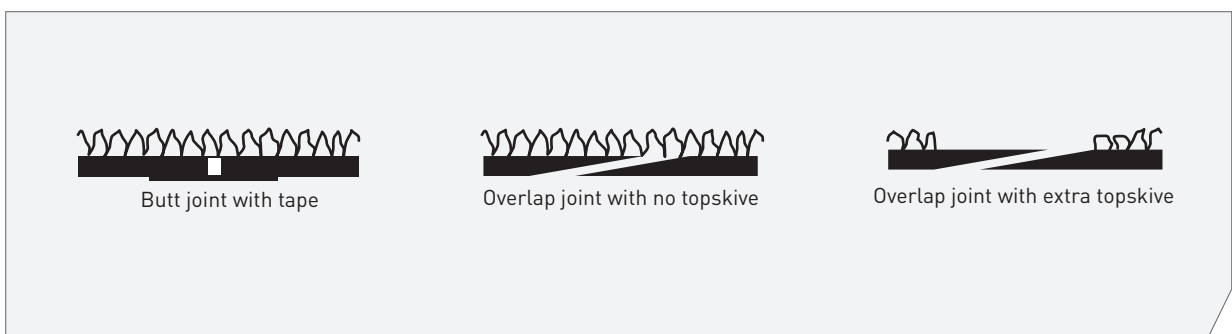

## NORaX AN INNOVATIVE TECHNOLOGY

NORaX is the innovative coated abrasive technology from Norton. The innovation lies in the abrasive layer: a multi-layer coating of abrasive is engineered into a 3D pattern. These patterns give a controlled contact surface between the abrasive and part that optimises belt performance.

NORaX works like a grinding wheel on a cloth backing. As the belt wears, dull abrasive particles are removed from the belt surface to expose a

new layer of sharp abrasives. This continuous replacement of dulled abrasives results in longer life, higher cut rates, and a more consistent surface finish throughout the belt life. Also, contributing to this higher performance, NORaX is also covered with a surface powder grinding aid that increases cut and life while decreasing grinding temperature.

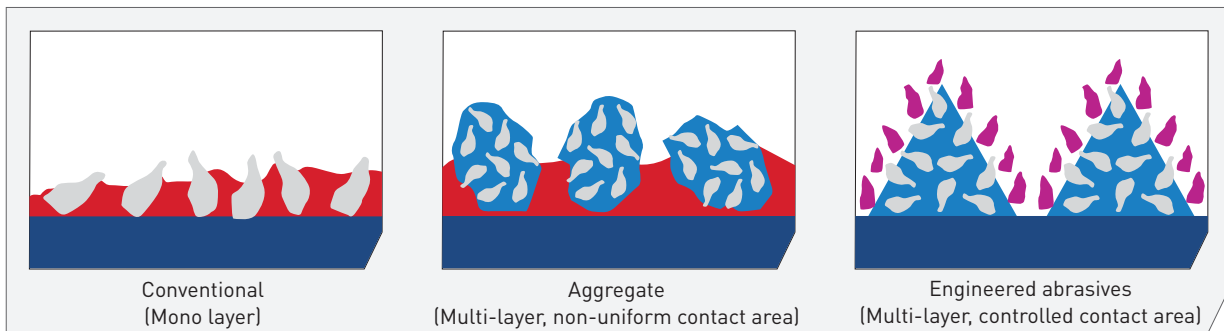

For more information on NORaX please contact your local Sales or Customer Service Representative.

## BACKING TYPES

Whether paper, cloth, vulcanised fibre, a combination or polyester film, the backing must be smooth enough for uniform adhesive coating, strong enough to withstand grinding pressures and flexible enough to conform to contours (if necessary). For reasons of economy, the least expensive backing compatible with the job requirements should be selected.

## PAPER

The standard paper weights used in coated abrasives are indicated by a letter code which appears immediately after the grit size on the finished product backing. Briefly stated, the lighter the backing, the greater the degree of flexibility; the heavier the backing, the greater the resistance to tearing.

### A-weight (70gms)

Light and flexible, A-weight is used primarily for hand finishing operations both wet and dry. Grits 80 and finer.

### C-weight (120gms)

Stronger and less flexible than A-weight. This backing is chosen for hand sanding, dry or wet, and for use on small portable power sanders. Intermediate through fine sanding. Grits 60 through 180.

### D-weight (150gms)

Stronger and less flexible than C-weight. This backing is also chosen for hand sanding and for use on small portable power sanders. Coarse through intermediate sanding. Grits 36 through 80.

### E-weight (220gms)

Stronger and less flexible than D-weight, this backing is used primarily on roll, belt and disc applications where high resistance to tearing is needed.

### F-weight (300gms)

The strongest, least flexible paper backing utilised. Used for crankshaft lapping rolls, tannery industry belts and rolls, and NorZon belts only.



## BACKING TYPES

### CLOTH

Cloth backings are more durable than paper, offer greater resistance to tearing, and tolerate continual bending and flexing during use. Norton use traditional woven cloth in the manufacture of their coated abrasives. The backing has construction and finishing characteristics designed to make it ideally suited to a specific application. The standard cloth weights used in coated abrasives are indicated by a letter code which appears immediately after the grit size on the finished product backing.

#### J-weight

The lightest and most flexible cloth backing, this backing is used where finish and uniformity of the surface are more important than stock removal. Ideal for finishing, blending and where flexibility and conformity are required, such as contour work or curved surfaces.

#### X-weight

Stronger and relatively stiff when compared to J-weight, this backing is used on products designed for coarse grit stock removal applications through fine grit finishing and polishing. Consistent productivity, relatively good finishes and long product life are characteristics of products made on X-weight backings.

#### Y-weight

Stronger and more resistant to longitudinal splitting than regular drills cloth, Y-weight backing is used on products designed for severe applications, such as narrow belt grinding of hand tools and wide belts sanding of lumber and particleboard dimensioning.

### FIBRE

Fibre backings, made of multiple layers of impregnated paper, are very hard and strong, yet provide sufficient flexibility for the intended applications. 0,8mm thick fibre has the greatest strength of any backing used for coated abrasives. This backing is used on resin bonded fibre discs designed for heavy duty portable grinding applications.

### COMBINATION

Combination backing, constructed by laminating light cloth and stiff E-weight paper, is used where resistance to tearing and breaking is a requirement. Primarily utilised on products designed for chipboard/MDF sanding.

### FILM

Polyester is used as the backing media for Norton's range of precision graded microfinishing products. Film backings can be used wet or dry and have excellent resistance to chemical attack, while being tear resistant and durable.

## SPECIAL COATED SURFACE TREATMENT

### NO-FIL TREATMENT

In order to provide even further resistance to loading, some Openkote paper products are given a special surface treatment of zinc stearate after the sizing operation. Such products are ideal for sanding between sealer coats on furniture, sanding after primer coats on automobiles, removing varnish from wood, and numerous other operations where conventional abrasive products fail prematurely due to loading.

Norton's trademark for products utilising this treatment is No-Fil.

## SURFACE FINISH & GRINDING EFFICIENCY VARIABLES

### SURFACE FINISH VARIABLES

Changes in any one of many factors can affect the surface finish generated by a product. The purpose of this chart is to show the effect on surface finish by changes in single factors of product specifications. Arrows have been used to signify the trend direction. The length of the arrows have no significance as the effect of each variable factor will not be the same. The chart is meant to be general in nature and to show direction or trend.

	VARIABLE FACTOR	ROUGH HIGHER RA READING	SMOOTH SURFACE LOWER RA READING
1.	Grit Size	Coarse	Fine
2.	C/A Product Condition	New	Used
3.	Adhesive Bond	Resin	Resin/Glue Glue
4.	Coating Method	Open-Coated	Close-Coated
5.	Product Flex	Single Linear	Double Triple
6.	Contact Wheel Configuration	Serrated	Smooth
7.	Composition	Wider Groove Width Steel	Rubber Wider Width Canvas
8.	Diameter	Smaller	Larger
9.	Belt Speed	Slower	Faster
10.	Grinding Aid	Dry	Water Oil Solubles Straight Oils Grease
11.	Abrasive Mineral Type	Zirconia Alumina	Ceramic Aluminium Oxide Silicon Carbide Emery
12.	Workpiece Hardness	Softer	Harder

## CUTTING EFFICIENCY

Although general in nature, this chart can serve as a useful guide as to what effect a change in a single given factor in the specification will have on the cutting efficiency of coated abrasive products. Arrows have been used to signify the trend direction. The length of arrows has no significance. Some important machine and setup parameters have also been included since they do have significant impact on product performance.

	VARIABLE FACTOR	MORE AGGRESSIVE BETTER CUT	SMOOTH SURFACE LOWER RA READING
1.	Workpiece Feed Speed	Slower ←	Faster →
2.	C/A Belt speed (m/s)	Slower ←	Faster →
3.	Abrasive Product Condition	New ←	Used →
4.	Grit Size	Coarse ←	Fine →
5.	Product Durability	Fibre ←	Cloth →
			Paper →
6.	Abrasive Mineral Type	Zirconia Alumina ←	Ceramic →
			Aluminium Oxide →
			Silicon Carbide →
			Emery →
7.	Adhesive Bond	Resin ←	Resin/Glue →
			Glue →
8.	Coating Method	Close-Coated ←	Open-Coated →
9.	Contact Wheel Configuration	Serrated ←	Smooth →
10.	Composition	Steel ←	Rubber →
			Canvas →
11.	Diameter	Smaller ←	Larger →
12.	Pressure	High ←	Low →
13.	Grinding Aid	Oil ←	Soluble Oil →
			Water →
			Dry →
14.	Workpiece Hardness	Softer ←	Harder →

## SAFETY ADVICE

### SAFETY IN THE STORAGE & USE OF COATED ABRASIVES

#### TRANSPORT & STORAGE

All coated abrasives should be handled carefully. Damage can be caused by mishandling, which should be avoided.

Coated abrasives should be stored in dry, frost free conditions. They should be kept away from heat sources, cold, damp walls, doors or windows and should not be in direct contact with the floor. Temperatures and humidity should be between 18°C and 22°C and 45%-65% relative humidity. Coated abrasives should not be exposed to direct sunlight. Products should be kept in their original packaging until immediately before use. Once unpacked, they should be stored in a way which avoids distortion.

#### PERSONAL PROTECTION

Safety goggles, ear defenders, safety gloves, dust masks and, if conditions are severe, additional face protection. Leather aprons and safety shoes must be worn.

#### GENERAL PRECAUTIONS

Safety instructions provided by the machine manufacturers must be followed. Where fitted, all guards, covers and hoods must be in place on the machine during grinding, and should not be modified in any way. Abrasives should not be used near inflammable material or in an environment where there is a risk of explosion.

Sparks should be directed away from the face and body, if possible towards the floor. Dust extraction equipment must be used whenever it is available. The instructions for use given by the abrasive manufacturer must be followed e.g. 'Not to be used without a support', or 'Not to be used for wet grinding'. The workpiece must be firmly fixed before grinding starts. Check all abrasives visually before use and make certain that the product is suitable for the application. No modifications should be made to abrasive products after delivery.

When using a portable grinder always switch it off and allow the spindle to stop completely before putting the tool down. Wet grinding should only be carried out on machines designed for this purpose and with abrasives designated as suitable for this type of operation.



Mouth Protection



Wear Gloves



Eye Protection



Ear Protection



Read Instructions



Dry



Wet

## TUNGSTEN CARBIDE BURRS

### DOs

✓	DO	Always operate the burr within the recommended speed range
✓	DO	Select the appropriate shape, diameter & cut style for the application
✓	DO	Ensure the appropriate grinder is used & that it is regularly maintained
✓	DO	Fix the maximum length of the burr in the collet (recommended max 10mm overhang)
✓	DO	Check that the burr is running true in the grinder before use
✓	DO	Securely fix workpiece & hold the grinder firmly
✓	DO	Use a smooth cutting action with constant movement in both directions. Use light pressure, letting the burr do the work
✓	DO	For best finish, always end on a reverse stroke

### DON'Ts





✗	DON'T	Run burr above the Maximum Operating Speed
✗	DON'T	Run burr too slowly (refer to recommended speed guide)
✗	DON'T	Allow burr to be exposed to excessive mechanical or thermal shock
✗	DON'T	Sink the burr to more than one-third of its periphery
✗	DON'T	Jam the burr into grooves, crevices & cavities
✗	DON'T	Allow burr to become too hot, causing braze to weaken (applies to burrs where head diameter is greater than shank diameter)
✗	DON'T	Apply shock or excessive force to the product or let it overheat

# BEARTEX





## PRODUCT SELECTION - BY MACHINE

### STATIONARY MACHINES

Product selection guide & Starting Points recommendation

MACHINES	PRODUCT	DEBURRING	CLEANING	BLENDING & FINISHING	REQUIRED ACCESSORY	
<b>STRAIGHT SHAFT EQUIPMENT</b>						
Bench Grinder		Plain Discs	n/a	F2303 HS Med A	F2520 VF A	n/a
		Convolute Wheels	D19 SF	DCS	DMA 5AM	Reduction Bushings
		Polybond Wheels	C150-H10BTM	n/a	C240-D4BTM	Reduction Bushings
		Flap Wheels	n/a	F2301 Med A	F2501 VF A	Reduction Bushings
		Unitised Wheels	U2301 8AM	U2401 6AF	U4401 2SF	Reduction Bushings
		Lap Mops	n/a	F2520 VF A	F2520 VF A	n/a
Pedestal Grinder		Plain Discs	n/a	F2303 HS Med A	F2520 VF A	n/a
		Convolute Wheels	D19 SF	DCS	DMA 5AM	Reduction Bushings
		Polybond Wheels	C150-H10BTM	n/a	C240-D4BTM	Reduction Bushings
		Flap Wheels	n/a	F2301 Med A	F2501 VF A	Reduction Bushings
		Unitised Wheels	U2301 8AM	U2401 6AF	U4401 2SF	Reduction Bushings
<b>BELT EQUIPMENT</b>						
Back Stand		Surface Blend Belts	DSB Coa or DSJ Ex Coa	DSJ Med	Superflex Med	n/a
Stroke Grinder		Surface Blend Belts	DSB Coa	DSJ Med	Superflex Med	n/a
Centerless Polisher		Surface Blend Belts	DSB Coa	DSJ Med	Superflex Med	n/a



MACHINES		PRODUCT	DEBURRING	CLEANING	BLENDING & FINISHING	REQUIRED ACCESSORY
<b>FEED-THROUGH EQUIPMENT</b>						
Sheet/Coil Processing Machine		Surface Blend Belts	DSB Coa	DSJ Med	Superflex Med	n/a
		Flap Wheels	n/a	F2301 Med A	F2501 VF A	Reduction Bushings
		Convolute Wheels	D18 SF	DCS	DMA 5AM	Reduction Bushings
Rotary Disc/Planetary Disc Machine		Surface Blend Discs	DSB Coa	DSJ Med	DSJ Med	n/a
<b>AUTOMATED EQUIPMENT</b>						
Rotary Machine		Plain Discs	n/a	F2303 HS Med A	F2520 VF A	n/a
		Convolute Wheels	D18 SF	DCS	DMA 5AM	Reduction Bushings
		Polybond Wheels	C150-H10BTM	n/a	C240-D4BTM	Reduction Bushings
		Surface Blend Belts	DSB Coa	DSJ Med	Superflex Med	n/a
		Unitised Wheels	U2301 8AM	U2401 6AF	U4401 2SF	Reduction Bushings
		Flap Wheels	n/a	F2301 Med A	F2501 VF A	Reduction Bushings
Straight-Line Machine		Plain Discs	n/a	F2303 HS Med A	F2520 VF A	n/a
		Convolute Wheels	D18 SF	DCS	DMA 5AM	Reduction Bushings
		Polybond Wheels	C150-H10BTM	n/a	C240-D4BTM	Reduction Bushings
		Surface Blend Belts	DSB Coa	DSJ Med	Superflex Med	n/a
		Unitised Wheels	U2301 8AM	U2401 6AF	U4401 2SF	Reduction Bushings
		Flap Wheels	n/a	F2301 Med A	F2501 VF A	Reduction Bushings
Centerless Polisher		Surface Blend Belts	DSB Coa	DSJ Med	Superflex Med	n/a
		Convolute Wheels	D18 SF	DCS	DMA 5AM	Reduction Bushings
		Polybond Wheels	C150-H10BTM	n/a	C240-D4BTM	Reduction Bushings



#### SPEC CHECK



Did you pick the most efficient solution?







The most cost effective method usually involves getting the job done fast and efficiently.

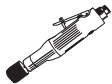

The most dramatic savings come from labour expenses, rather than material costs.

MACHINES		PRODUCT	DEBURRING	CLEANING	BLENDING & FINISHING	REQUIRED ACCESSORY
<b>AUTOMATED EQUIPMENT</b>						
Robotic Equipment		Surface Blend Discs	DSB Coa	DSJ Med	DSJ Med	n/a
		Convolute Wheels	D18 SF	DCS	DMA 5AM	Reduction Bushings
		Polybond Wheels	C150-H10BTM	n/a	C240-D4BTM	Reduction Bushings
		Surface Blend Belts	DSB Coa	DSJ Med	Superflex Med	n/a
		Flap Wheels	n/a	F2301 Med A	F2501 VF A	Reduction Bushings
		Plain Discs	n/a	F2303 HS Med A	F2520 VF A	n/a
		Unitised Wheels	U2301 8AM	U2401 6AF	U4401 2SF	Reduction Bushings

## PORTABLE MACHINES

MACHINES		PRODUCT	DEBURRING	CLEANING	BLENDING & FINISHING	REQUIRED ACCESSORY
<b>STRAIGHT-SHAFT TOOLS</b>						
Drill		Plain Discs	n/a	F2303 HS Med A	F2520 VF A	Mandrels
		Convolute Wheels	D16 SF	DCS	DMA 5AM	Mandrels
		Polybond Wheels	C150-H10BTM	n/a	C240-D4BTM	Mandrels
		Flap Wheels (Spindle)	n/a	F2301 Med A	F2501 VF A	n/a
		Unitised Wheels	U2301 8AM	U2401 6AF	U4401 2SF	Mandrels
		RapidStrip Wheels/Discs	n/a	R4101 S Ex Coa	n/a	Mandrels
		Lap Mops	n/a	F2520 VF A	F2520 VF A	XL Mandrels
Straight-Shaft Grinder		Plain Discs	n/a	F2303 HS Med A	F2520 VF A	Mandrels
		Convolute Wheels	D19 SF	DCS	DMA 5AM	Mandrels
		Unitised Wheels	U2301 8AM	U2401 6AF	U4401 2SF	Mandrels
		RapidStrip Wheels	n/a	R4101 S Ex Coa	n/a	Mandrels
		Flap Wheels (Spindle)	n/a	F2301 Med A	F2501 VF A	n/a

MACHINES	PRODUCT	DEBURRING	CLEANING	BLENDING & FINISHING	REQUIRED ACCESSORY	
<b>STRAIGHT-SHAFT TOOLS</b>						
Die Grinder		Flap Wheels (Spindle)	n/a	F2301 Med A	F2501 VF A	n/a
		Unitised Wheels	U2301 8AM	U2401 6AF	U4401 2SF	Mandrels
		Lap Mops	n/a	F2520 VF A	F2520 VF A	XL Mandrels
Flexible-Shaft Motor e.g. Suhner, Biax		Plain Discs	n/a	F2303 HS Med A	F2520 VF A	Mandrels
		Convolute Wheels	D16 SF	DCS	DMA 5AM	Mandrels
		Polybond Wheels	C150-H10BTM	n/a	C240-D4BTM	Mandrels
		Surface Blend Belts	DSB Coa	DSJ Med	Superflex Med	n/a
		Unitised Wheels	U2301 8AM	U2401 6AF	U4401 2SF	Mandrels
		RapidStrip Wheels	n/a	R4101 S Ex Coa	n/a	Mandrels
		Flap Wheels	n/a	F2301 Med A	F2501 VF A	Mandrels
<b>RIGHT ANGLE TOOLS</b>						
Right Angle Grinder/Polisher		Surface Blend Discs	DSB Coa	DSJ Med	DSJ Med	Self-Grip back up pads
		RapidStrip DPC discs	n/a	R4101 S Ex Coa	n/a	n/a
		RapidFinish DPC discs	U2301 2AM	F2303 HS Med A	U4401 2SF	n/a
		SpeedLok Discs	DSB Coa	R4101 S Ex Coa	DSJ Med	SpeedLok Holders
Vertical Grinder		Surface Blend Discs	DSB Coa	DSJ Med	DSJ Med	Self-Grip back up pads
Right Angle Die Grinder/Mini Grinder		SpeedLok Discs	DSB Coa	R4101 S Ex Coa	DSJ Med	SpeedLok Holders
		Specialised SpeedLok discs	U2301 6AM	F2303 HS Med A	U4401 2SF	SpeedLok Holders
Satinex machine		Satinex Wheels	F2200 A Coa	R4101 S Ex Coa	F2300 Med A	n/a

MACHINES	PRODUCT	DEBURRING	CLEANING	BLENDING & FINISHING	REQUIRED ACCESSORY	
<b>BELT TOOLS</b>						
File		Surface blend File belts	DSB Coa	DSJ Med	Superflex Med	n/a
Portable Belt Sander		Surface Blend Belts	DSB Coa	DSJ Med	Superflex Med	n/a
Expander Wheel		Surface Blend Belts	DSB Coa	DSJ Med	Superflex Med	n/a
<b>VIBRATING TOOLS</b>						
Orbital Sander		Plain Discs	n/a	F2303 HS Med A	F2520 VF A	Self-Grip back up pads
		Surface Blend Discs	DSB Coa	DSJ Med	DSJ Med	Self-Grip back up pads
Straight- Line Sander		Hand Pads	F2302 Extra Cut A	F2504 VF A LL	F4804 UF S	n/a
		Rolls	F2300 Med A	F2504 VF A LL	F4804 UF S	n/a
<b>HAND PAD / MANUAL SANDING</b>						
Hand Applications		Hand Pads	F2302 Extra Cut A	F2504 VF A LL	F4804 UF S	n/a
		Rolls	F2300 Med A	F2504 VF A LL	F4804 UF S	n/a
		Sheets	F2302 Extra Cut A	F2504 VF A LL	F4807 UF S	n/a

Warning - Do not use a product which was not designed specifically for that tool.  
Always verify that the speed rating of the product meets or exceeds the rating of the tool!



#### SPEC CHECK

Starting point recommendations can vary depending on the level of aggression required, by choosing a different product grade  
Depending upon performance results, other specifications may be substituted on the basis of product testing.  
The best practice is to test at least 2 variations of specifications to obtain the desired result.

Ask your Norton contact for more advice.

## PRODUCT SELECTION- BY APPLICATION

SHORTCUT TO FINDING THE RIGHT PRODUCT...

For deburring or cleaning/finishing, or on completely new operations, the product specifications listed below are recommended as starting points.

Depending upon performance results, other specifications may be substituted on the basis of product testing.

We believe that the best practice is to test at least 2 variations of specifications to obtain the desired result.

### DEBURRING

Medium Burrs	Light Burrs
CONVOLUTE WHEELS	
Series 1000 Long Life 1 - 8 SF C4408	Series 1000 Long Life 1 - 7 SF C4408
or (for extra cut)	
Series 1000 Long Life 1 - 9 SF C4408	
UNITISED WHEELS	
NEX -6AM (or 8AM) U2301	NEX -2SF U4401
For Ti and Aerospace Alloys, use 6SF U4401	
RIGHT ANGLE DISCS	
Surface Blending DSJ or DSB	Surface Blending DSJ
Aluminium Oxide 120 Medium	Aluminium Oxide 320 Very Fine
HAND PADS	
F2302 Heavy Duty Extra Cut Tan Pad	F2504 VFA LL Maroon General Purp Pad

### WOOD CONDITIONING

Sanding and Shaping	Finishing and Rubbing
CONVOLUTE WHEELS	
Series 1000 Long Life 1 - 8 SM C4308	F2801 Micro Fine S Gold Pad

## CLEANING AND FINISHING

Clean / Medium Grain Finishing	Fine Grain Finishing
CONVOLUTE WHEELS	
DSS Surf Fin S/C Med Wheel C4302	DCS Clean/Finish S/C Fine Wheel C4401
or	or
Series 1000 Long Life 1 - 6 SM, C4308	Series 1000 Long Life 1 - 6 SF C4408
UNITISED WHEELS	
NEX -4AF U2401	NEX -2SF U4401
FLAP WHEELS	
Med Grit Aluminium Oxide F2301	Fine Grit Aluminium Oxide F2401
Medium Density Flap Wheel	Medium Density Flap Wheel
HAND PADS	
F2504 VFA LL Maroon General Purp	F2801 Micro Fine S Gold Pad
or	
F4300 Medium S Pad for stainless steel	

## HAND PAD APPLICATIONS

Heavy Duty Cleaning & rust removal	Medium Cleaning	Light Cleaning & Finishing
HAND PADS		
F2302 Heavy Duty Extra Cut Pad Tan	F2504 VFA LL General Purpose Pad Maroon	F2801 Mfine S Pad Gold



## MATERIAL IDENTIFICATION

PRODUCT SHAPE	COLOUR	GRADE	GRIT TYPE	SIZE	FIBRE	STRENGTH
Flastock - Hand Pads - Rolls	White	White Cleaning	None	None	Polyester	Least Aggressive - Most Aggressive
	Green	General Purpose Clean & Scour	Aluminium Oxide	320	Nylon	
	Gold	Micro Fine A	Aluminium Oxide	1000		
	Gray	Ultra Fine S	Silicon Carbide	800		
	Maroon	Very Fine A	Aluminium Oxide	320		
	Maroon	Fine A	Aluminium Oxide	180		
	Maroon	Medium A	Aluminium Oxide	120		
	Brown	Extra Cut	Aluminium Oxide	80		
	Black	Medium S	Silicon Carbide	60		
Bearflex	Gold	Micro Fine A	Fused Alumina	1000	Nylon	
	Maroon	Very Fine A	Aluminium Oxide	600		
	Gray	Ultra Fine S	Silicon Carbide	320		
High Strength	Maroon	Very Fine A	Aluminium Oxide	280	Nylon	
	Maroon	Medium A	Aluminium Oxide	100		
Surface Blending SCM Discs and Belts	Gray	Super Fine	Silicon Carbide	600	Nylon	
	Blue	Very Fine A	Aluminium Oxide	180		
	Maroon	Medium	Aluminium Oxide	100		
	Maroon	Heavy Medium	Aluminium Oxide	80		
	Brown	Coarse	Aluminium Oxide	50		
	Dark Brown	Extra Coarse	Aluminium Oxide	46		
Rapid Strip	Black	Extra Coarse	Silicon Carbide	36	Nylon	
Floor Pads Thick Line General Purpose	White	White Super Gloss	None		Nylon	Least Aggressive - Most Aggressive
	Beige	Beige Polish & Burnish	Aluminium Oxide			
	Maroon	Red Buffer	Aluminium Oxide			
	Blue	Blue Super Clean	Aluminium Oxide			
	Green	Green Super Scrub	Aluminium Oxide			
	Black	Black Super Strip	Aluminium Oxide			
Floor Pads Thin Line General Purpose	White	White	None		Nylon	Least - Most Aggressive
	Tan	Tan	Aluminium Oxide			
	Green	General Purpose Pad	Aluminium Oxide			
	Black	Black Strip	Aluminium Oxide			

Finishing characteristics of non-woven abrasives are determined by many attributes in addition to grain size, the data provided here is for reference only - and cannot be considered as a specification of our products.

Sizes - colours are approximate.

## SAFETY ADVICE - DO'S & DON'TS

For your safety you should ensure that you are fully aware of how to safely use abrasives

✓	DO	Read the safety instructions provided by the abrasives and equipment supplier
✓	DO	Store abrasives in dry, frost-free conditions avoiding wide variations in temperature
✓	DO	Ensure that the product is suitable for its purpose
✓	DO	Handle, store and transport products with care
✓	DO	Disconnect the power to the machine before fitting the product
✓	DO	Examine all products before mounting and periodically during use for possible defects or damage (core flatness, fatigue cracks, undercutting, arbor hole damage...)
✓	DO	Check that correct mounting devices are used and that they are clean, undistorted and free from burrs
✓	DO	Ensure that work rests are properly adjusted and secure
✓	DO	Always use a correctly designed and adjusted guard (on belts)
✓	DO	Ensure that the workpiece is secure
✓	DO	Wear appropriate personal protective equipment at all times
✓	DO	Avoid clogging and uneven wear to ensure that the product is working efficiently
✓	DO	Ensure accordance between product direction arrow / machine rotation
✓	DO	Ensure that all machines using abrasives meet the requirements of the current european machinery directives-CE
✓	DO	<p>Be aware of the hazards likely during the use of abrasives and observe the recommended precautions to be taken:</p> <ul style="list-style-type: none"> <li>• Bodily contact with the abrasive product at operating speed</li> <li>• Injury resulting from product breakage during use</li> <li>• Grinding debris, sparks, fumes and dust generated by the grinding process</li> <li>• Noise</li> <li>• Vibration</li> </ul>

## SAFETY ADVICE - DO'S & DON'TS

For your safety you should ensure that you are fully aware of how to safely use abrasives.

<b>X</b>	DON'T	Allow untrained people to use abrasives
<b>X</b>	DON'T	Use a product that is damaged
<b>X</b>	DON'T	Use a product if it cannot be properly identified
<b>X</b>	DON'T	Use a machine that is not in good working order or one with defective parts
<b>X</b>	DON'T	Force the abrasive onto the mounting device or modify the size of the mounting hole
<b>X</b>	DON'T	Exceed the maximum operating speed marked on the product
<b>X</b>	DON'T	Apply shock or excessive force to the product or let it overheat
<b>X</b>	DON'T	Use mounting flanges which are not clean and flat
<b>X</b>	DON'T	Tighten the mounting device excessively
<b>X</b>	DON'T	Start the machine until the guard is in place and fastened securely
<b>X</b>	DON'T	Continue to use a product if vibration occurs. True or replace it
<b>X</b>	DON'T	Grind on the part of the product which is not designed for the operation
<b>X</b>	DON'T	Start the machine with the workpiece in contact with the abrasive product
<b>X</b>	DON'T	Grind material for which the product is not designed
<b>X</b>	DON'T	Stop the abrasive by applying pressure to its surface, let it stop naturally
<b>X</b>	DON'T	Wear loose clothing, ties and jewellery
<b>X</b>	DON'T	Use abrasive products near flammable materials

# BONDED ABRASIVES

## TECHNICAL INFORMATION

### WHAT IS A GRINDING WHEEL?

A grinding wheel is a precision tool with thousands of cutting points. It consists of abrasive grains held in a matrix of bond and separated by pores. The abrasive grains are the cutting points while the purpose of the bond is to hold the individual grains together. The pores (hollow spaces between adjacent abrasive grains and the bond) serve to provide clearance for coolant penetration and metal chips removed in the grinding process.

When the wheel is rotated at grinding speed and applied to the workpiece, the abrasive grains cut the material that is being ground, removing the material in small chips.

Under the action of the forces imposed during grinding the abrasive cutting points are worn flat, resulting in the points becoming blunt. This causes an increase in friction, and a build up of heat.

The increase in grinding forces causes either the abrasive to fracture, exposing new cutting edges, or fractures the bond bridges holding the abrasive grains. In the latter case fresh abrasive grains are exposed to cut the workpiece.

In normal vitrified grinding applications the wheel has to be dressed.

By varying the properties of the abrasive, the type of bond, the make-up of the wheel, it is possible to produce grinding wheels with a vast range of different grinding characteristics.

### ABRASIVES

Modern synthetic abrasives allow accurate control over the physical properties and form of the abrasive grain. This helps to ensure that grinding wheels can be manufactured with consistent cutting properties.

Norton offers a comprehensive selection of abrasive types to provide a wide range of specific grinding characteristics. This is necessary for maximum efficiency in the large variety of operations demanded by the industry today.

#### Abrasive Grain Size

The grain or grit size is most important in determining a wheel's ability to achieve the required surface finish and remove stock. The size is designated by a number which increases as grain size decreases.

For example 10 grit has a median size of about 2,0mm and 60 grit 0,25mm.

Standard sizes are used in all Norton wheels as specified in the European Standards laid down by FEPA.

An ideal grinding abrasive has the ability to stay sharp with minimum point dulling, and when dulling begins it fractures revealing new sharp cutting edges. Abrasive grains used in the manufacture of bonded abrasives come in three main categories.

### UNDERSTANDING THE SPECIFICATION

ABRASIVE			GRIT SIZE			GRADE			STRUCTURE		BOND
ALUMINIUM OXIDE	SILICON CARBIDE	CERAMIC ALUMINIUM OXIDE	COARSE	MEDIUM	FINE	SOFT	MEDIUM	HARD	CLOSED	OPEN	
A	37C	SGB	12	30	80	E	I	Q	5	10	VS
19A	39C	3SG	16	36	90	F	J	R		11	VXP
25A		5SG	20	46	100	G	K	S		12	VXPM
38A		1TGP	24	54	120	H	L	T			VTECH
40A				60			M				
57A				70			N				
86A							O				
IPA				60				EH XH		17 20	VTX
		ES5		60	80		J K	L			VX

## ABRASIVE TYPES

ABRASIVE TYPE	DESCRIPTION
A	This is a particularly tough form of aluminium oxide. Its toughness is due to the presence of 3% of titanium oxide in the abrasive. Fired at low temperature the abrasive retains its natural brown colour. Fired at high temperature further oxidation of the titanium oxide takes place which changes the normal brown colour to a grey-blue. Because of its toughness, regular brown alumina is suitable for grinding high tensile strength materials, specifically off-hand grinding (bench grinding wheels) & sharpening stones.
19A	A blend of A & 38A abrasives. This abrasive gives a grinding action that can be compared to the average of its components. It is supplied in some standard tool room wheels, used for surface, cylindrical, centreless & miscellaneous grinding on less heat sensitive steels.
38A	White fused aluminium oxide (99,8% pure). The most friable & cool cutting of the aluminium oxides. This abrasive is supplied in all types of standard range wheels ideal for use on hard & heat sensitive steels & alloys. It has traditionally been used for sharpening high-speed steel & cast alloy tools & cutters. 38A is used for cylindrical, surface & internal grinding of tools, dies & gauges.
57A	Semi-pure brown fused aluminium oxide (98% pure). The higher purity of 57A makes it a good general purpose abrasive. Its versatility enables it to be used for grinding steel parts in both soft & hard states, especially on large cylindrical & centreless operations. U Treatment (U57A) is a ceramic coating applied to this abrasive to increase its durability in resin bonded cutting-off wheels. It is used in the advanced range resinoid cut-off wheels.
86A	Pink aluminium oxide is a highly refined form of alumina containing a small proportion of chromium oxide. This addition makes 86A a little tougher than pure white, increasing the strength along the shear planes. This abrasive is available in a range of mounted points & wheels.
SGB	A blend of premium abrasives that include a medium concentration of ceramic Norton SG.
3SG	A blend of premium abrasives that include a high concentration of ceramic Norton SG.
5SG	A blend of premium abrasives that include a very high concentration of ceramic Norton SG.
37C	Crystolon silicon carbide abrasive. Supplied mainly in the resin bonds of advanced wheels used for grinding grey iron, non-ferrous metals & in vitrified bonds for grinding non-metallic materials, such as rubber & stone.
39C	Crystolon is the highest purity silicon carbide abrasive. It is ideal for grinding cemented carbide cutting tools, fired ceramics & glass, where it provides advanced performance.

## BOND TYPES

### VITRIFIED

Vitrified bonds are the most common precision grinding bond. Porosity and strength of the wheels made with this bond give high stock removal along with their rigidity helping to attain high precision. Not affected by water, acid, oils or ordinary temperature variations. The most common vitrified bonds are:

V	V is the original high temperature vitrified bond, usually used where tougher acting wheels are required
VS	VS is a very versatile, low temperature, high performance vitrified bond system used in almost all applications but predominately for tool room, centreless, cylindrical, & surface grinding
VTECH	Low temperature, very technical bond, used with conventional abrasives & recommended for high tech applications to maximise performance & dressing parameters
VX	VX bond provides improved corner/form holding for most applications – it is the first choice bond for our premium abrasives
VXP	Induced porosity VX bond suitable for large contact areas & surface grinding

## BOND TYPES

### ORGANIC

These bonds are used in two types of wheels. Firstly, wheels used on portable or fixed machines for the rapid removal of metal. Secondly, cutting-off wheels either un-reinforced or reinforced, for use on portable or fixed machines. The most common organic bonds are:

#### SNAGGING WHEELS & CUPS

B & B3	Foundry wheels: multi-purpose bond that gives satisfactory results on most applications
B28	Foundry wheels: high level bond suitable for most technical applications requiring high powered machines

#### CUTTING-OFF WHEELS

BF1	Specific bond ensuring the best quality of cut in dry or wet conditions
BF3	New generation bond assuring the best wheel life in dry cutting operations; versatile & long wheel life. Ideal for heavy duty operations
B24	New generation bond used on silicon carbide cut-off wheels that gives the best performance & the ultimate cut quality on non-ferrous metals in wet conditions
B25	Standard multi-purpose bond that offers durability & freeness of cut in a wide variety of materials & applications. Can also be used in wet cutting on softer grades
B26	New generation bond used on aluminium oxide cut-off wheels that gives the best performance & the ultimate cut quality on ferrous metals in wet conditions
B65	Traditional bond gives good performance & long wheel life in dry cutting conditions

## WHEEL GRADES

The grade indicates the relative holding power of the bond, which holds abrasive grains in a wheel. This is represented in the specification by letters running through the alphabet from hardest to softest. The following rules should be followed with regard to grade:

#### USE SOFT GRADE

- For hard materials such as hard tool steels & carbides
- For large areas of contact
- For rapid stock removal

#### USE HARD GRADE

- For soft materials
- For small or narrow areas on contact
- For longer wheel life

#### COMMON RANGE OF GRADES

E	F	G	H	I	J	K	L	M	N	O	P	Q	R	S	T	U
					CYLINDRICAL/CENTRELESS											
SURFACE GRINDING																
					ID GRINDING											
				TOOL GRINDING												
					THREAD GRINDING											
NON-REINFORCED ORGANIC																
											REINFORCED ORGANIC					



## AVAILABILITY SUMMARY

ABRASIVE TYPE	BOND	ABRASIVE COLOUR
IPA	VTX	White
SGB-3SG-5SG-ES5-1TGP	VX-VXP	Blue
A-19A	VS	Brown
86A	VS-VXP-VTECH	Ruby
38A	VS	White
37C	V-VP	Black
39C	V-VS	Green

## SELECTING THE RIGHT PRODUCT

There are nine main factors to be considered when selecting a grinding wheel for any application:

- The material to be ground – its type & hardness
- The stock to be removed
- The workpiece geometry & surface finishes required
- The grinding machine, the type of machine, the power available & its conditions
- Wheel speeds & feeds
- Grinding contact area
- Grinding fluid – whether the operation is wet or dry
- The severity of the grinding operation
- The dressing method

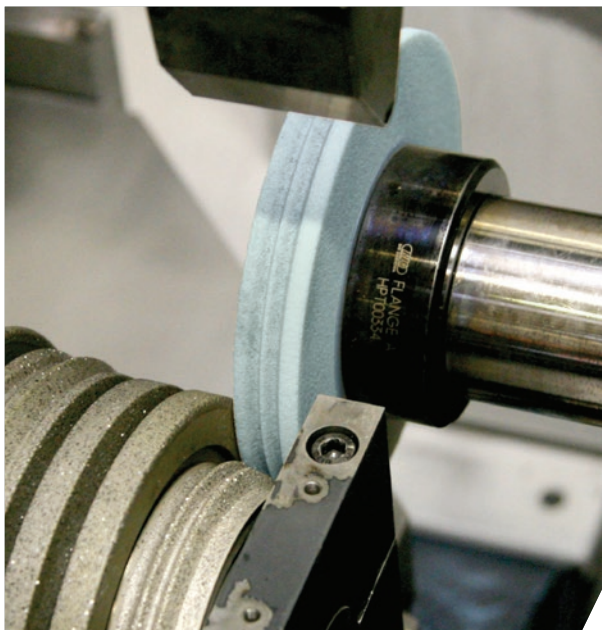

### MATERIAL TO BE GROUND

The type of material affects the selection of abrasive, grit size and grade. Alumina type abrasives are the most suitable for grinding high tensile materials such as steel and ferritic cast irons. The more friable types of alumina are preferred on harder steels and applications having large arcs of contact.

Low tensile strength materials and non-metallic materials are most efficiently ground or cut with silicon carbide abrasive.

The hardness of the material governs the amount of penetration that can be achieved by the abrasive. For this reason finer grit size wheels are required to grind hard materials and soft materials are best ground with medium to coarse grit size wheels.

For most efficient operation, the grade must be adjusted to suit the hardness of the material. As a general guide, the harder the material, the softer the grade of wheel required.

### STOCK TO BE REMOVED

This affects the choice of abrasive size and bond type.

High stock removal rates, as in fettling operations, require coarse grit wheels, typically 12 to 24 mesh. Fine finishes and tight limits on finished workpiece geometry require finer grit sizes.

Final surface finish is often achieved by 'spark out'. No further infeed is applied and the wheel is allowed to grind until the majority of the grinding sparks cease.

## SURFACE FINISH

Usage Key ● Highly recommended		SURFACE FINISH & GRIT SIZE							
SURFACE	FINISH	GRAIN SIZE							
μ in CLA	μ m Ra	46	60	80	100	120	150	180	220
42	1,10	●							
32	0,80	●							
26	0,70	●							
21	0,50		●						
16	0,40		●						
14	0,35		●	●					
11	0,25		●	●					
8	0,20			●	●				
7	0,17			●	●	●			
6	0,14				●	●	●		
5	0,12					●	●	●	
4	0,10						●	●	●
3	0,08							●	●
2	0,05								●
MIN FORM RADIUS	METRIC (mm)	0,75	0,50	0,40	0,25	0,20	0,18	0,13	0,10
	IMP INS	,030	,020	,015	,010	,008	,007	,005	,004

The achievable surface finish in any grinding operation is highly dependent upon the grit size of the grinding wheel. The following chart shows the range of surface finishes achievable when using grinding wheels of different grit sizes on conventional precision grinding applications, together with the minimum form radius that can be ground using each grit size.

Other factors can affect the surface finish achieved. In particular:

- Production grinding applications, with higher stock removal ranges, will give surface finishes at the coarser end of the range
- Plunge grinding applications will often require the selection of a grit size one size finer than shown
- Dressing techniques & the type of material can also affect the surface finish achieved

### ACHIEVING IMPROVED SURFACE FINISHES

By changing the wheel dressing technique, it is possible to achieve finer surface finishes than those shown. As well as reducing the dresser infeed per revolution of the grinding wheel, it is also possible to reduce the infeed and traverse rate when grinding, thus reducing the stock removal rate. Obviously this approach will have limited application in production grinding but it can be very useful in tool room work.

## THE GRINDING MACHINE

The type of machine can effectively define the grinding contact area and the ease with which grinding fluid can be applied to the grinding zone.

The power available on the machine governs the stock removal rate. The greater the power available, the harder the grade of wheel that is required for efficient operation.

Any deterioration in the condition of machine bearings and slideways will lead to vibration and, consequently, premature wheel breakdown. This can, in part, be overcome by using a harder grade wheel and/or a tougher abrasive but the only effective solution is to maintain the machine as recommended by the machine manufacturer.

## SPEEDS & FEEDS

The effect of speeds and feeds on grinding action and, hence, the selection of wheel, can best be summarised in the following table:

### EFFECT ON GRINDING ACTION

SPEED	INCREASED	DECREASED
Wheel speed*	Harder	Softer
Work speed	Softer	Harder
Traverse speed	Softer	Harder
Infeed rate	Softer	Harder

\*The maximum peripheral speed (m/s) specified for the wheel must never be exceeded

## GRINDING CONTACT AREA

The contact area affects the selection of wheel grade and structure. Large contact areas, as on segmental grinders, generally produce low grinding pressures and require soft grade, open structure wheels. Induced porosity wheels are most efficient for grinding very large contact areas. Conversely, small contact areas, as on cylindrical grinding machines, require harder grade and/or closer structure wheels.

The size of workpiece can also affect the grinding contact area. In general, the larger the workpiece, relative to the grinding wheel diameter, the larger the contact area, requiring softer grade wheels.

## GRINDING FLUID

Dry grinding with vitrified wheels require wheels one or two grades softer than when wet grinding.

## SEVERITY OF THE GRINDING OPERATION

This can affect the choice of abrasive type, grade and even bond type. Where the wheel is subjected to shock loads, as in fettling operations, a resinoid bond should be used. In general, the more severe the grinding operation, the harder the grade of wheel required and the tougher the abrasive that can be used. Severity of grinding operation can be due to heavy infeeds, high work speeds and traverse rates or intermittent grinding contact. The latter is usually due to workpiece geometry, resulting in a dressing action on the wheel.

## GRINDING WHEEL DRESSING & TRUING

Truing and dressing of grinding wheels are often considered to be the same thing, since they are frequently performed as one operation. Truing is performed to ensure concentricity and introduce any profile that may be required on the wheel face. Dressing conditions the wheel surface to give the desired cutting action.

## SINGLE & MULTI-POINT DIAMONDS

Diamonds are the first choice where close tolerances, fine finishes, speed and flexibility are required. Since diamond dressing is primarily a machining operation rather than a crushing operation, the surface formed on the wheel is closer than that obtained from mechanical dressers. This results in a slower cutting wheel with better form holding characteristics and superior finish control.

By varying the depth of cut per pass made by the diamond and changing the traverse rate, different wheel surfaces, and hence different cutting actions, can be achieved.

The following are general recommendations for dressing with single-point diamonds.

	ROUGHING	FINISHING
Diamond infeed mm per pass	0,025mm	0,012-0,020mm
Diamond traverse rate mm/wheel rev.	0,18mm	0,10mm

The diamond should always be applied at the centreline of the wheel with a 5°-15° drag angle.

## DIAMOND SIZE

The size of diamond is important when selecting a dressing tool and several factors are relevant in this selection, e.g. large, coarse grit wheels require a larger diamond than smaller, fine grit wheels. If a fine finish is required, the use of a diamond which is too large can adversely affect the finish and cancel the effect of fine grit selection. The trend today is away from single-point dressers and towards multi-point dressers employing a matrix shape to suit the form required.

A useful formula for determining single-point & multi-point diamond size is:

Wheel diameter (mm) x Wheel thickness (mm)

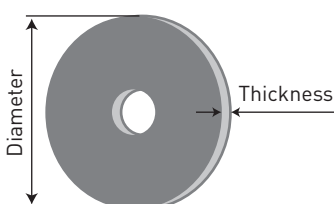
SINGLE-POINT	MULTIPLY THE DIAMETER OF THE WHEEL BY ITS THICKNESS	
	Diameter x Thickness (mm)	Carat
	<6000	0,33 Carat
	6000-18000	0,50 Carat
	>18000	1,0 Carat

For best results, always use a coolant when dressing

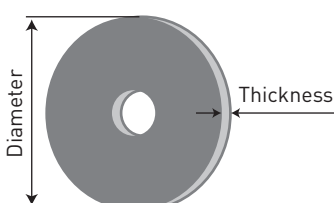
MULTI-POINT	MULTIPLY THE DIAMETER OF THE WHEEL BY ITS THICKNESS	
	Diameter x Thickness (mm)	Carat
	<30000	1,3 Carat
	30000-60000	2,5 Carat
	>60000	5,0 Carat

For best results, always use a coolant when dressing

## COOLANT

Dressing with diamonds should always be carried out using a copious supply of coolant. The coolant should always be turned on fully before the diamond touches the wheel. The diamond life will deteriorate rapidly if it is allowed to become hot and then cooled rapidly as can be experienced with an intermittent coolant flow.

## ROTATION OF THE DRESSING TOOL

To ensure maximum diamond life, single-point and conical cluster diamond dressing tools should be systematically rotated after every four or five dressings to ensure that the keen edge generated from the drag angle is constantly presented to the wheel.

## REDUCTION RINGS

Plastic reduction rings may be used to adapt grinding wheels to fit on various spindle sizes. These rings reduce the bore hole size, allowing the wheel to be safely mounted on a spindle with a smaller diameter.

- Reduction rings should never come in contact with the flange
- Reduction rings should not be used on wheels of thicknesses less than 6mm, nor greater than 50mm
- Always use one reduction ring on each side of the wheel when the wheel is thick enough to allow correct seating
- Never use reduction rings to reduce the hole below the minimum specified in the FEPA safety code

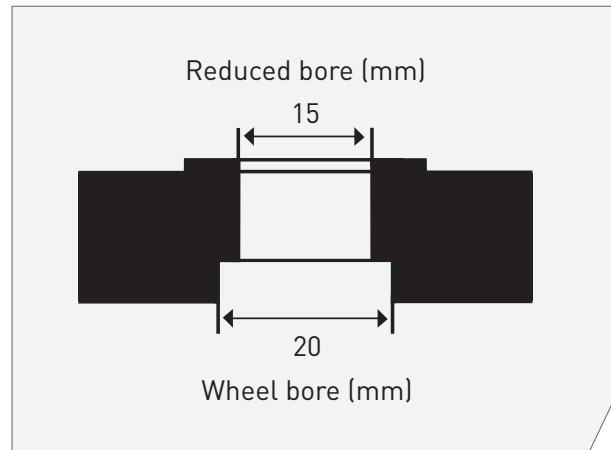

WHEEL BORE (mm)	REDUCED TO (mm)	REDUCTION RING
50,8	35	07660704766
32	25	07660717540
32	20	07660717538
31,75	15,88	07660704757
31,75	12,7	07660704755
20	16	07660717530
20	15	07660717529
20	13	07660717527
20	12	07660717525
20	10	07660717524
16	6	00510008919

## MOUNTING

A wheel should only be mounted onto the machine for which it was intended. The speed of the spindle on which the wheel is mounted should not under any circumstances exceed the maximum RPM speed specified for the wheel when it is full size. The wheel should fit freely, but not loosely, onto the spindle or spigot diameter of the flange plates. Wheels, blotting paper washers and flanges should be free from foreign matter. Certain wheels have a positioning mark (Mount Down or Mount Up) marked on them. Care must be taken to ensure that this mark occupies the position stated by the manufacturer.

### REDUCING BUSHES

Where a removable bush is used as a means of reducing the bore of an abrasive wheel, care must be taken to ensure the bushes should not project beyond the side of the wheel and the wheel blotter. The clamping faces of the flange plates **MUST** clamp on the mounting washers attached to the wheel and not on any part of the reducing bush. Reducing bushes should never be used on wheels less than 6mm thick or on products with a back or web of less than 6mm. Never use plastic bushes on wheels used with portable grinding equipment.

### MOUNTING WASHERS

Blotters should be used with all grinding wheels unless there is a specific exemption. Blotters should be slightly larger in diameter than the mounting flanges and free from any scuffs, wrinkles or other damage.

### MOUNTING FLANGES

Mounting flanges are designed to clamp the wheel to the machine and transfer the driving forces from the machine spindle to the grinding wheel. They should be designed to take the driving forces away from the area around the grinding wheel bore and generally should be not less than one third of the grinding wheel diameter.

Flange surfaces should be flat, free from burrs, bumps, bruises and other damage. Flanges should be of equal diameter, have equal bearing surfaces and be properly recessed or undercut.

The rear flange must be positively driven by the machine spindle, being either keyed or shrunk onto the spindle.

Flanges must run true to the machine spindle.

Clamping nuts (centre nut locking) should only be tightened sufficiently to hold the wheel securely without slippage and must not be over-tightened. When flanges are clamped by a series of screws, they should be tightened in stages uniformly in a diametric sequence.

In most instances it is appropriate to tighten the nut or screws by hand with the correct tool (spanner or hexagonal socket key) until they stop turning. By adopting this technique it is very rare that the wheel would be under-tightened and impossible to over-tighten the wheel. Bolts for mounting wheels with inserted nuts should be long enough to engage an adequate length of thread, i.e. equal to the thread diameter, but must not protrude through the nut insert.

For recommended designs of flanges, refer to the FEPA Safety Guidelines.

### CAUTION

After mounting or re-mounting a grinding wheel on a machine, stand well clear, ensuring that there are no persons in line with the wheel and allow the wheel to run free for two minutes. A re-mounted wheel should always be treated as if it were a new wheel.

### TYPE 06 CUP WHEELS – FIXED MACHINES

The diameter of the flange and paper washer inside the cup must be smaller than the diameter of the cup recess to avoid any risk of radial pressure on the wheel. When used for work heavier than light tool and cutter grinding, the back flange may be larger than that inside the cup but the recess diameter of both flanges must be equal.

### MOUNTED POINTS & WHEELS

The spindle dimensions of the mounted point must be suitable for the collet being used, and the spindle overhang corresponding to the machine speed should be observed.

### TYPE 31 GRINDING SEGMENTS

Segments are held by special chucks with suitable provision for adjustment to compensate for segment wear. To prevent breakages segments should not protrude more than 1,5 times their thickness from the clamping chuck face, and should be mounted with markings uppermost.



## WHEEL BALANCE

Most Norton grinding wheels are balance corrected to a minimum of ISO Standards. Precision grinding machines usually provide methods of accurately balancing the complete wheel and flange assembly. Modern production machines are now supplied with automatic balancing systems, whereas, tool room and older production machines still have to be manually balanced, ensuring the best possible grinding performance from the wheel.

The balancing procedure can be carried out either on a special balancing stand or in-situ on the machine. The machine manufacturer's instructions should be closely followed. There are many methods of manually balancing the wheel assembly, depending upon the number of balance weights in the wheel arbour. A typical 'two weight' balancing system technique is described below:

## TWO WEIGHT SYSTEMS

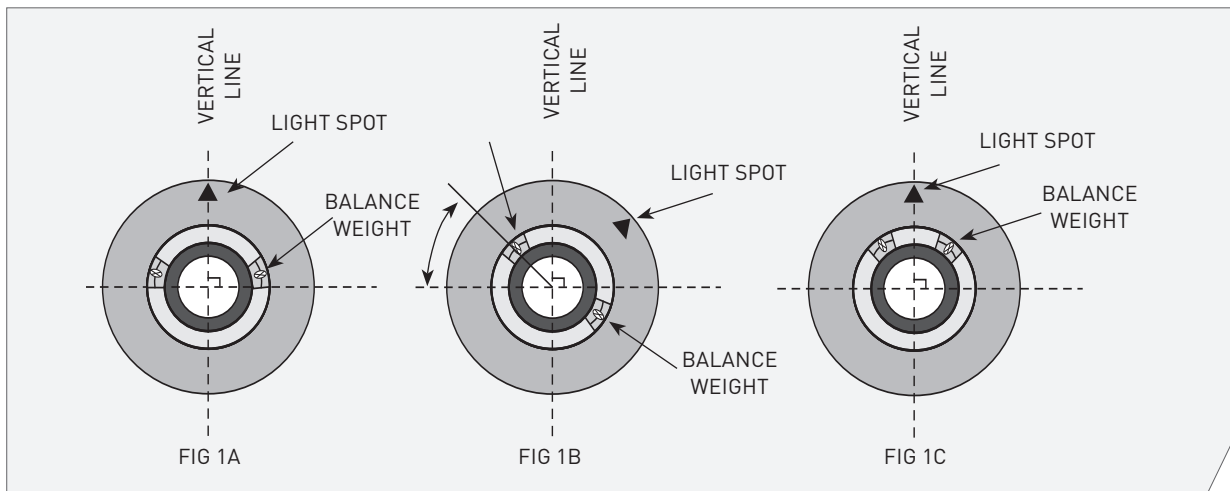

- Mount wheel between flange plates
- Remove balance weights from annular groove on mounting flange (can also be set diametrically opposite if preferred – ensuring the weights cancel each other out)
- Dress periphery of wheel until running in perfect truth
- Remove complete wheel assembly from the machine (after allowing sufficient time for the coolant to spin out) & fix assembly onto the balancing mandrel
- Place on balancing unit & allow to turn freely. When stationary, mark top centre (light spot) with chalk
- Re-position the balance weights so that the bottom side face of each weight, that is furthest from the light spot, forms a right angle i.e. 90°. See illustration 1A
- Turn wheel assembly so that one balance weight is approximately 45 degrees from the horizontal line & release the wheel. Note the direction in which wheel rotates, the weight may revolve upwards towards the vertical line. In this instance the weight should be moved down away from the light spot (always adjust the weights in the opposite direction of rotation) to begin bringing the wheel into balance. See illustration 1B
- Continue checking the weights, alternating between the left & right hand balance weights in turn. Repeat until the wheel remains stationary in all positions. Move the weights a maximum of 3mm at a time, reducing this amount as the wheel rotates slower. See illustration 1C
- Continue until assembly remains static in all positions. Lock balancing weights in position & remount assembly onto the machine spindle
- Important: – Ensure the balancing ways (knife edges or rollers) on the balancing stand are level in all directions. Care must be taken to initially find the true light spot of the wheel

## TROUBLESHOOTING

### SOLVING SURFACE FINISH PROBLEMS

Many problems associated with grinding relate to surface finish defects. The following chart describes some common surface finish problems, shows the probable causes and suggests remedies to cure the problem.

#### REGULAR SPACED CHATTER MARKS

Immediately after dressing

Cause	Machine vibration
Solution	Check for wear in machine bearings

#### REGULAR SPACED CHATTER MARKS

After a period of time

Cause	Wheel too hard
Solution	Use softer grade of wheel

#### CHEQUERED PATTERN

Cause	Wheel out of balance
Solution	Balance wheel

#### CHATTER MARKS

Cause	Wheel out of truth
Solution	Re-dress wheel

#### IRREGULAR CHATTER MARKS

Cause	Wheel mounting insecure
Solution	Tighten wheel mounting
Cause	Workpiece centres loose
Solution	Adjust centres

#### SPIRAL MARKS

Cause	Dressing techniques
Solution	Check diamond is sharp & secure
Cause	Dressing techniques
Solution	Check dress is parallel

#### FINISH TOO COARSE

Cause	Grit size too coarse
Solution	Use fine, slow traverse dress
Cause	Wheel too soft
Solution	Decrease workspeed. Use harder grade wheel
Cause	Metal pick-up on wheel
Solution	Dress more frequently. Use more open, softer grade wheel

## SAFETY ADVICE

### SAFETY IN THE STORAGE & USE OF GRINDING WHEELS

Stringent safety standards are maintained throughout the manufacture of Norton Grinding Wheels. To reduce the risk of accidents further, the law requires that certain basic precautions are taken in the storage and use of abrasive wheels.

#### RECEIPT

On receipt, grinding wheels should be thoroughly examined to see if they show any signs of damage, such as chips, cracks or discolouration. Damaged wheels must not be used.

#### HANDLING

Any mishandling that results in the wheel being subjected to any shock loading can damage all grinding wheels. This can occur if the wheel is inadvertently dropped, knocked over or banged against any other object. This is equally true if the wheel is secured on a pallet, which has been dropped heavily from a forklift truck.

Any grinding wheel subjected to such mishandling should be carefully examined for signs of damage. If in any doubt – do not use.

#### STORAGE

Small wheels up to 80mm diameter, together with cones, plugs, mounted points and wheels may be stored in suitable bins, drawers or boxes. Type 02 cylinder wheels, type 06 straight cup wheels, type 12 dish wheels and type 13 saucer wheels should normally be stacked on flat sides with cushioning material between them. Thick rim and hard grade cylinder and straight cup wheels may be stored on their periphery as for plain wheels. Soft grade, straight cup wheels, and all type 11 taper cup wheels, should be stored base to base and rim to rim, to prevent chipping of edges and cracking of walls. Thin plain wheels, such as cutting-off wheels or saw sharpening wheels should be stacked on a flat surface of steel, or similar rigid material. Other plain or shaped wheels of appreciable thickness, are best supported on their periphery in racks. The racks should provide cushioned, two point, cradle support to prevent the wheels from rolling.

#### STORAGE CONDITIONS

During storage, grinding wheels must not be subjected to:

- Exposure to humidity, water or other liquids
- Freezing temperatures
- Any temperature low enough to cause the formation of condensation on the wheels when moving from storage to an area of high temperature

#### SHELF LIFE OF RESINOID

##### & VITRIFIED BONDED WHEELS

The outer surfaces of certain organically bonded wheels may be affected by oxidation if they are stored for long periods. These types of wheel should not be stored for more than three years and proper stock control should ensure that older wheels are used first. In use, a three year old Resinoid product will act considerably softer than a brand new wheel (wheel will wear away more quickly).

The glass bonding system used in vitrified wheels is very inert and generally only attacked by certain acids. Cold temperatures can result in a vitrified wheel cracking if wheels are put away wet and are subjected to freezing temperatures. It must be remembered that the longer a product is in storage the chances of it becoming damaged increases. Provided vitrified wheels are stored correctly, thoroughly examined and mounted correctly they will last for many years.

#### RING TEST

The ring test depends upon the damping characteristics of a cracked wheel to alter the sound emitted when it is lightly tapped. The test is applicable only to vitrified bonded wheels.

To perform the ring test; support the wheel gently with a finger through the bore section. Using a light non-metallic implement (a file handle is ideal), gently tap the wheel about 45° each side of the vertical centre line. Rotate the wheel 45° and repeat the test.

The sound and undamaged wheel will omit a clear tone. If cracked, there will be a dead dull sound – not a clear ring – and the wheel should NOT be used. The ring test should be carried out in a place where the ring can easily be heard.

## SAFE WORKING PRACTICES

### PERSONAL PROTECTION

Safety goggles, ear defenders, safety gloves, dust masks and, if conditions are severe, additional face protection. Leather aprons and safety shoes must be worn.

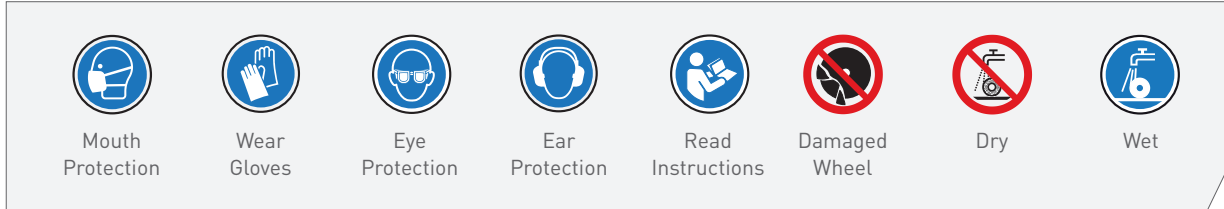

### TRAINING OF OPERATORS

Grinding operators should be trained in the safe use of each machine they operate.

### SPEEDS

No abrasive wheel should be operated at a speed in excess of the maximum permissible speed marked on the wheel in RPM when the wheel is new and full size. It is permissible, however, to increase the spindle speed of the machine beyond the RPM stated on the wheel provided the increase is in proportion to the reduction in diameter and that the original peripheral speed is not exceeded (quoted on the wheel in metres/sec). In high production areas it is now normal for machines to have constant peripheral speed spindles. This is an electronic device that automatically increases the spindle speed of the machine as the wheel diameter wears down and prevents most of the reduction in wheel performance that is experienced when the wheel becomes smaller.

### COOLANTS

The strength of resin bonded grinding wheels can be reduced by coolants. The concentration and alkalinity of coolants should be regularly checked and a pH value of 8 should not be exceeded. Prolonged immersion of a stationary wheel in coolant can produce an out of balance condition. Coolant should be shut off before stopping a wet grinding wheel, and the wheel allowed to run free until all the coolant has been spun out.

### WORK RESTS

Work rests should be kept adjusted as close as possible (gap between wheel and work rest should not exceed 3mm) to the wheel and maintained in good condition.

### TRUING & DRESSING

Re-dressing of wheels that have become malformed and out of truth in off-hand operations must only be performed by a competent person.

If an out of balance condition, due to the wheel wearing excessively out-of-round, cannot be

corrected by truing, the wheel should be removed from the machine. Wheels should be dressed regularly to avoid loading

### SIDE GRINDING

Side grinding should only be performed with wheels designed for this purpose (straight cups etc.).

Grinding on the flat sides of wheels designed for peripheral grinding may be dangerous and cause a wheel breakage. This does not preclude their use for certain precision applications such as shoulder and form grinding, where it is recognised that a limited amount of side grinding is performed; however, in these operations the operator has control of the pressure through the hand wheels of the machine whereas with bench grinding and off-hand machines the pressure is uncontrolled. Extreme caution should be exercised not to use excessive pressure.

As a general guide, do not use a straight wheel which has a thickness of less than 10% of the wheel diameter for side grinding.

### ORGANIC CUTTING-OFF WHEELS

'Non-reinforced' cutting-off wheels should never be used:

- On a portable grinding machine
- On any machine where the workpiece is fed into the wheel by hand

Cutting-off wheels should only be mounted on machines designed for their use.

Cutting-off wheels should be inspected for warping before use. Warped wheels should not be used.

When grinding, twisting or the exertion of any pressure on the side of the wheel should be avoided.

Workpieces should be rigidly supported and firmly clamped wherever possible.

### STOPPING WHEELS

Wheels should not be brought to rest by applying pressure to the periphery or face of the wheel.

# SUPER ABRASIVES

## TECHNICAL INFORMATION

### DESIGNATION OF GRIT SIZES

FEPA MICRONS	US MESH	JIS	DWMI	DIAMOND	CBN	Ra (µm) SURFACE FINISH CARBIDE	RA (µm) SURFACE FINISH STEEL PLUNGE	RA (µm) SURFACE FINISH STEEL OSCILLATING
1181	16/18							
1182	16/20			16				
1001	18/20							
851	20/25							
852	20/30	20		24	24			
711	25/30							
601	30/35							
602	30/40	30		36	36			
501	35/40							
426	40/45							
427	40/50	40		46	46			
356	45/50							
301	50/60	50		50	50			
	50/80							
251	60/70			60	60			
252	60/80	60	60	80c	80c	0,6-0,9		
213	70/80			80	80			
181	80/100	80	80	100	100	0,4-0,7	1,0-1,1	0,9-1,1
	80/120			110c				
151	100/120	100	100	110	120		0,9-1,0	0,8-0,9
126	120/140	120	120	120	150	0,4-0,5	0,8-0,9	0,6-0,8
107	140/170	140	150	150	180		0,6-0,8	0,5-0,6
91	170/200	170	180	180	220	0,3-0,4	0,5-0,6	0,4-0,5
76	200/230	200	220	220	230			
64	230/270	230	240	240	240	0,2-0,3	0,4-0,5	
54	270/325	270	320	320	320			
46	325/400	325	400	400	400	0,1-0,2		
	400/500	400		500	500			
M63	40/60							
M40	30/40	500		500				
M25	20/30	700						
	15/25	800						
M16	*10/20*	1000		600				
	*8/16*	1500						
M10	*6/12*	2000		800				
M6,3	*4/8*	2500						
	*3/6*	4000						
M4	*2/4*	5000						
M1	*0/2*	15000						



## CONCENTRATION

The concentration is defined by a standard and indicates the weight of abrasive (in carats) contained in 1cm<sup>3</sup> of abrasive strip – 1 carat = 0,2 grams.

CONCENTRATION*			NUMBER OF CARATS/cm <sup>3</sup>	ABRASIVE WEIGHT PER cm <sup>3</sup>
DIAMOND ABRASIVE	=	CBN ABRASIVE*		
100	=	W	4,4	= 0,88g/cm <sup>3</sup>
75	=	T	3,3	= 0,66g/cm <sup>3</sup>
50	=	Q	2,2	= 0,44g/cm <sup>3</sup>

\* Other concentrations available upon request

## SELECTION OF CONCENTRATION

The choice of concentration depends on the machining parameters:

HIGH CONCENTRATION			MEDIUM OR LOW CONCENTRATION	
Roughing operations			Finishing operation	
Powerful machine			Low power machine	
Small contact area			Large contact area	
Retention of profile or sharp edges of wheel			Cutting without temperature rise	
OPERATION	INTERNAL GRINDING	EXTERNAL GRINDING	SURFACE GRINDING	SHARPENING
Diamond	100	75	50	50/75
CBN	W	T	Q	Q/T

## COOLANT

Generally speaking, working with coolant is preferable to working without coolant because the coolant reduces friction and dissipates heat generated by machining.

However, many sharpening operations are performed without coolant under good conditions and with appropriate bonds.

Choice of coolant:

- DIAMOND wheel = pure water + 1,5% rust inhibitor or soluble oil
- CBN wheels = pure oil or water, always with 5 to 10% soluble oil
- For CBN wheels, changing from soluble oil to pure oil increases the service life of the wheel

## MOUNTING, TRUING & DRESSING

To achieve the best results using Norton Diamond and CBN products, the following steps for mounting, truing and dressing should be practised:

### MOUNTING – PUTTING WHEEL ON MACHINE SPINDLE

- Examine wheel flanges & spindle carefully
- Be sure flanges' surfaces are clean & free of damage
- Ensure that the mounting flanges are flat & of equal diameter, especially on wheels with rigid centres, such as vitrified bond wheels
- Inspect machine spindle for excessive runout – TIR (Total Indicated Runout) should be no greater than 5 microns



- Mount wheel between hand-tightened flanges
- Using a dial indicator, tap the wheel lightly with a rubber or wooden block to minimize runout to less than 25 microns
- Tighten flange securely & recheck with indicator
- Allow a newly mounted wheel to operate for one full minute before grinding
- The use of one permanent mounting for the life of the wheel is recommended whenever possible:
  - If the grinding machine has a tapered spindle, mount each straight, flaring cup or dish wheel on a separate collet or adapter
  - When changing wheels the entire unit is removed, keeping the wheel in running truth
  - When needed again, the entire unit can be placed directly on the spindle or arbor, thereby eliminating the time & abrasive lost in retrueing

## TRUING – MAKING WHEEL ROUND & CONCENTRIC WITH THE SPINDLE AXIS

- Prior to truing the wheel, run a wax crayon over the wheel face. Important: do not use any liquid based ink on super abrasive wheels
- Any crayon left on the wheel face after truing will reveal untrued areas
- Norton Brake Controlled Truing Devices are most commonly used to true Diamond & CBN straight, cup & cylinder wheels
  - Always use Brake Controlled Truing Device dry
  - Bring the Diamond/CBN wheel & the truing wheel together until they almost touch
  - Start the Diamond/CBN wheel to normal speed; start the truing wheel in the same direction
  - Bring the two wheels together until they touch
  - Make sure the truing wheel is spinning at time of contact
  - Traverse the wheel back & forth at 10-20mm/s
  - Downfeed 0,01-0,02mm at the end of each traverse
  - At the end of truing, the Diamond/CBN wheel should be smooth & in truth

## DRESSING - OPENING THE FACE OF A TRUED WHEEL

The core material (the part of the wheel that holds and supports the abrasive-bearing section) should never contact the workpiece during grinding; rubbing will generate excessive heat. As the abrasive section of a cup wheel wears, the core material may become exposed - necessitating dressing.

- Use a single-point carbide or steel tool to dress an exposed resaloy core
- Clamp the tool in a vice
- Direct the cutting edge accurately to leave a 1,5mm of abrasive section exposed

## DRESSING THE ABRASIVE TO EXPOSE THE GRITS

**Purpose:** to expose the grinding stone face to give a better cut

After each truing operation, dressing is necessary to give a more precise cut to the wheel. This operation consists of highlighting the grits by eliminating part of the bond and is generally carried out using vitrified bonded abrasive sticks.

Selection of the stick specification depends mainly on the nature of the bond of the super abrasive grinding stone and its grit size.

### STICKS RECOMMENDED

BOND	GRIT SIZE	TRUING STICKS
Resin	126 & bigger	38A 150 HVBE
	107 - grit - 64	38A 220 HVBE
	54 & finer	38A 320 HVBE

## TROUBLESHOOTING

### USE RIGID WORK SUPPORT

- All workpieces should be supported firmly during the grinding process. Any amount of vibration will cause wheel wear & produce chatter or wave marks on the ground surface
- On work ground between centres, centreholds should be properly prepared
- Minimise work overhang
- If the ground work is supported by a work finger, ensure the finger is strong enough to provide vibration-free support

### AVOID EXCESSIVE FEEDS

- Excessive feeds will result in premature wheel wear. Excessive feed rates are characterised by:
  - A hard grinding sound
  - Chatter
  - Burn
  - High wheel wear rate
  - Vibration

## DRY GRINDING

### BURNING (EXCESSIVE HEAT)

Cause	Wheel loaded or glazed
Solution	Dress wheel with a dressing stick
Cause	Excessive feed rate
Solution	Reduce infeed of wheel or workpiece
Cause	Wheel too durable
Solution	Use freer cutting specification or slow down wheel speed
Cause	Wheel speed too high
Solution	Slower wheel speed

### POOR FINISH

Cause	Grit size too coarse
Solution	Select a finer grit size
Cause	Excessive feed rate
Solution	Reduce infeed of wheel or workpiece

### CHATTER

Cause	Wheel out of truth
Solution	True wheel; ensure it is not slipping on mount
Cause	Wheel too hard
Solution	Check specification

## WET GRINDING

### BURNING (EXCESSIVE HEAT)

Cause	Wheel glazed or loaded
Solution	Re-dress wheel
Cause	Poor coolant placement
Solution	Apply coolant directly to wheel/workpiece interface
Cause	Excessive material removal rate
Solution	Reduce downfeed &/or crossfeed
Cause	Wheel speed too high
Solution	Slower wheel speed

### POOR FINISH

Cause	Excessive dressing
Solution	Use lighter dressing pressure Stop dressing as soon as wheel starts to consume stick rapidly
Cause	Grit size too coarse
Solution	Select a finer grit size
Cause	Poor coolant flow or location
Solution	Apply heavy flood so it reaches wheel/work interface

### CHATTER

Cause	Wheel out of truth
Solution	True wheel; ensure it is not slipping on mount
Cause	Wheel too hard
Solution	Check specification

### WHEEL WILL NOT CUT

Cause	Glazed by truing
Solution	Dress lightly until wheel opens up
Cause	Wheel loaded
Solution	Dress lightly until wheel opens up Increase coolant flow to keep wheel surface clean Never run wheel with coolant turned off
Cause	Grit size too fine
Solution	Check specification

### SLOW CUTTING

Cause	Low feeds & speeds
Solution	Increase feed rate; increase wheel speed (observe maximum wheel speed)

### SHORT WHEEL LIFE

Cause	Incorrect coolant flow
Solution	Apply coolant to flood wheel/work surface
Cause	Low wheel speed
Solution	Increase wheel speed (observe maximum operating speed)
Cause	Excessive dressing
Solution	Use lighter dressing pressure
Cause	Wheel too soft or too hard
Solution	Change grit or grade; use higher concentration

# DIAMOND BLADES

## TECHNICAL INFORMATION

### OPERATING SPEEDS









MAXIMUM OPERATING SPEED		
DIAMETER (mm)	MAX M/S	MAX RPM
100	80	15300
115	80	13300
125	80	12250
150	80	10200
180	80	8500
200	80	7650
230	80	6650
250	80	6100
300	100	6400
350	100	5500
400	100	4800
450	63	2700

Never exceed the Maximum Operating Speeds:

- Hand held blades  $\varnothing \leq 230\text{mm}$ : 80m/s
- Hand held blades  $\varnothing > 230\text{mm}$ : 100m/s
- Others: 63m/s

### PERSONAL PROTECTION

Safety goggles, ear defenders, safety gloves, dust masks and, if conditions are severe, additional face protection. Leather aprons and safety shoes must be worn.

							
Mouth Protection	Wear Gloves	Eye Protection	Ear Protection	Read Instructions	Not for Side Grinding	Dry Cutting	Wet Cutting

## TROUBLESHOOTING

### DIAMOND BLADE DOES NOT CUT

Cause	The segments are too hard for the material
Solution	Check if the blade is suitable for the material
Cause	The segments have become blunt
Solution	Sharpen the segments by cutting an abrasive material (e.g. sandstone)
Cause	Insufficient machine power
Solution	Check the voltage, machine power & filters

### EXCESSIVE WEAR

Cause	The segment is too soft for the material (e.g. if a blade for hard material is used to cut abrasive material)
Solution	Check if the diamond blade is suitable for the material

### CRACKING OF STEEL CENTRE

Cause	The segments are too hard for the material
Solution	Check if the blade is suitable for the material
Cause	Excessive cutting pressure, overheating, material slippage, twisting or jamming in the cut
Solution	Leave the blade to do the work, do not exert too much pressure & allow the blade to cool regularly by leaving it to rotate away from the workpiece for a few seconds

### LOOSENING OR CRACKING OF SEGMENTS

Cause	The segments are too hard for the material. This results in the diamond blade bouncing in the cut resulting in cracking segments
Solution	Check if the diamond blade is suitable for the material

### SCORCHING OF SEGMENTS

Cause	Excessive cutting pressure causing overheating. This is easily recognisable from the blue colouring where the segments & the steel core are welded together
Solution	Allow the diamond blade to cool regularly by rotating the blade away from the workpiece for a few seconds
Cause	The segments are too hard for the material
Solution	Check if the diamond blade is suitable for the material. Alternatively use less cutting pressure & let the blade do the work

### UNDERCUTTING

Cause	Undercutting occurs when the steel core wears faster than the segment, i.e. where the segment & steel core meet. This is usually caused by materials that are highly abrasive. The cutting debris is not removed sufficiently & the steel core is affected. Undercutting is certain to occur if a diamond blade for hard materials is used to cut abrasive materials
Solution	Use a diamond blade suitable for the specific material

## SAFETY ADVICE

### SAFETY D0s

For your safety you should ensure that you are fully aware of how to safely use diamond blades

✓	D0	Read the safety instructions provided by the abrasives & equipment supplier
✓	D0	Store abrasives in dry, frost-free conditions avoiding wide variations in temperature
✓	D0	Ensure that the product is suitable for its purpose
✓	D0	Handle, store & transport products with care
✓	D0	Disconnect the power to the machine before fitting the product
✓	D0	Examine all products before mounting & periodically during blade use for possible defects or damage (core flatness, fatigue cracks, undercutting, arbor hole damage...)
✓	D0	Check that correct mounting devices are used & that they are clean, undistorted and free from burrs
✓	D0	Ensure that work rests are properly adjusted & secure
✓	D0	Always use a correctly designed & adjusted guard (on the blade and belts)
✓	D0	Ensure that the workpiece is secure
✓	D0	Wear appropriate personal protective equipment at all times
✓	D0	Avoid clogging & uneven wear to ensure that the product is working efficiently
✓	D0	Ensure accordance between product direction arrow / machine rotation
✓	D0	Ensure that all machines using abrasives meet the requirements of the current European machinery directives-CE
✓	D0	<p>Be aware of the hazards likely during the use of abrasives &amp; observe the recommended precautions to be taken:</p> <ul style="list-style-type: none"> <li>• Bodily contact with the abrasive product at operating speed</li> <li>• Injury resulting from product breakage during use</li> <li>• Grinding debris, sparks, fumes &amp; dust generated by the grinding process</li> <li>• Noise</li> <li>• Vibration</li> </ul>



## SAFETY DON'Ts

For your safety you should ensure that you are fully aware of how to safely use diamond blades

<b>X</b>	DON'T	Allow untrained people to use abrasives
<b>X</b>	DON'T	Use a product that is damaged or one which has been dropped
<b>X</b>	DON'T	Use a product if it cannot be properly identified
<b>X</b>	DON'T	Use a machine that is not in good working order or one with defective parts
<b>X</b>	DON'T	Force the abrasive onto the mounting device or modify the size of the mounting hole
<b>X</b>	DON'T	Exceed the maximum operating speed marked on the product
<b>X</b>	DON'T	Apply shock or excessive force to the product or let it overheat
<b>X</b>	DON'T	Use mounting flanges which are not clean & flat
<b>X</b>	DON'T	Tighten the mounting device excessively
<b>X</b>	DON'T	Start the machine until the guard is in place & fastened securely
<b>X</b>	DON'T	Continue to use a product if vibration occurs. True or replace it
<b>X</b>	DON'T	Grind on the part of the product which is not designed for the operation
<b>X</b>	DON'T	Start the machine with the workpiece in contact with the abrasive product
<b>X</b>	DON'T	Grind material for which the product is not designed
<b>X</b>	DON'T	Stop the abrasive by applying pressure to its surface, let it stop naturally
<b>X</b>	DON'T	Exceed permissible rotation speeds: refer to values engraved on product
<b>X</b>	DON'T	Use blades with missing segments or core cracks
<b>X</b>	DON'T	Use dry products marked for wet use
<b>X</b>	DON'T	Wear loose clothing, ties & jewellery



Reshaping  
your  
world.



**NORTON**<sup>®</sup>  
SAINT-GOBAIN



SAINT-GOBAIN ABRASIVES NV/SA  
INDUSTRIELAAN 129  
1070 ANDERLECHT  
BRUSSELS  
BELGIUM  
TEL: +32 2 267 21 00  
FAX: +32 2 267 84 24

SAINT-GOBAIN ABRASIVES, S.R.O.  
POČERNICKÁ 272/96, MALEŠICE  
108 00 PRAHA 10  
CZECH REPUBLIC  
TEL: +420 255 719 326  
FAX: +420 255 719 321

SAINT-GOBAIN ABRASIVES A/S  
ROBERT JACOBSENS VEJ 62A  
2300 KØBENHAVN S  
DENMARK  
TEL: +45 4675 5244

PO BOX 643706  
FORTUNE TOWER OFFICE 2106  
JLT BLOCK C  
(NEXT TO METRO STATION)  
JUMEIRA LAKE TOWER, DUBAI  
UNITED ARAB EMIRATES  
TEL: +971 4 431 5154  
FAX: +971 4 431 5434

SAINT-GOBAIN ABRASIFS  
RUE DE L'AMBAassadeUR - B.P.8  
78 702 CONFLANS CEDEX  
FRANCE  
TEL: +33 (0)1 34 90 40 00  
FAX: +33 (0)1 34 90 43 97

SAINT-GOBAIN ABRASIVES GMBH  
BIRKENSTRASSE 45-49  
D-50389 WESSELING  
GERMANY  
TEL: +49 (0) 2236 703-1  
+49 (0) 2236 8996-0  
+49 (0) 2236 8911-0  
FAX: +49 (0) 2236 703-367  
+49 (0) 2236 8996-10  
+49 (0) 2236 8911-30

FÜR DEN FACHHANDEL ÖSTERREICH  
TEL: +43 (00) 662 430 076

SAINT-GOBAIN ABRASIVES KFT.  
1225 BUDAPEST  
BÁNYALÉG U. 60/B.  
HUNGARY  
TEL: +36 1 371 22 50  
FAX: +36 1 371 22 55

SAINT-GOBAIN ABRASIVI S.P.A.  
VIA PER CESANO BOSCONI 4  
I-20094 CORSICO MILANO  
ITALY  
TEL: +39 02 44 851  
FAX: +39 02 44 78 266

SAINT-GOBAIN ABRASIVES S.A.  
190 RUE J.F. KENNEDY  
L-4930 BASCHARAGE  
GRAND DUCHE DE LUXEMBOURG  
TEL: +352 50 401 1  
FAX: +352 50 16 33  
NO. VERT (FRANCE) 0800 906 903

SAINT-GOBAIN ABRASIFS, S.A.  
2 ALLÉE DES FIGUIERS  
AIN SEBAÂ - CASABLANCA  
MOROCCO  
TEL: +212 5 22 66 57 31  
FAX: +212 5 22 35 09 65

SAINT-GOBAIN ABRASIVES BV  
GROENLOSEWEG 28  
7151 HW EIBERGEN  
P.O. BOX 10  
7150 AA EIBERGEN  
THE NETHERLANDS  
TEL: +31 545 466466  
FAX: +31 545 474605

SAINT-GOBAIN ABRASIVES AS  
POSTBOKS 11, ALNABRU, 0614 OSLO  
BROBEKKVEIEN 84  
0582 OSLO  
NORWAY  
TEL: +47 63 87 06 00  
FAX: +47 63 87 06 01

SAINT-GOBAIN HPM POLSKA SP. Z O.O.  
UL. NORTON 1  
62-600 KOŁO  
POLAND  
TEL: +48 63 26 17 100  
FAX: +48 63 27 20 401

SAINT-GOBAIN ABRASIVOS, L. DA  
ZONA INDUSTRIAL DA MAIA  
I-SECTOR VIII, NO. 122  
APARTADO 6050  
4476 - 908 MAIA  
PORTUGAL  
TEL: +351 229 437 940  
FAX: +351 229 437 949

SAINT-GOBAIN GLASS,  
BUSINESS UNIT ABRASIVI  
PUNCT DE LUCRU:  
LOC.VETIS, JUD. SATU MARE  
447355, STR. CAREIULUI 11,  
PARC INDUSTRIAL RENOVATIO  
ROMANIA  
TEL: +40 261 839 709  
FAX: +40 261 839 710

SG HPM RUS  
58, F. ENGELS STR.  
STROENIE 2  
105082 MOSCOW  
RUSSIA  
TEL: +74 955 408 355  
FAX: +74 959 373 224

SAINT-GOBAIN ABRASIVES (PTY) LTD  
2 MONTEER ROAD  
ISANDO 1600  
P.O. BOX 67  
SOUTH AFRICA  
TEL: +27 11 961 2000  
FAX: +27 11 961 2184/5

SAINT-GOBAIN ABRASIVOS, S.A.  
CTRA. DE GUIPÚZCOA, KM. 7.5  
E-31195 BERRIOPLANO (NAVARRA)  
SPAIN  
TEL: +34 948 306 000  
FAX: +34 948 306 042

SAINT-GOBAIN ABRASIVES AB  
BOX 495  
SE-191 24 SOLLENTUNA  
SWEDEN  
TEL: +46 8 580 881 00  
FAX: +46 8 580 881 01

SAINT-GOBAIN INOVATIF MALZEMELER VE  
AŞINDIRICI SAN. TIC. A.Ş.  
GOLD PLAZA, ALTAY ÇEŞME MAHALLESİ,  
ÖZ SOKAK, NO:19/16  
34843 MALTEPE-ISTANBUL ,  
TURKEY  
TEL: 0090-216-217 12 50  
FAX: 0090-216-442 40 74

SAINT-GOBAIN ABRASIVES  
DOXEY RD  
STAFFORD  
ST16 1EA  
UNITED KINGDOM  
TEL: +44 1785 222 000  
FAX: +44 1785 213 487



Saint-Gobain Abrasifs  
European Headquarters  
Rue de l'Ambassadeur - B.P.8  
78 702 Conflans Cedex  
France

Tel: +33 (0)1 34 90 40 00  
Fax: +33 (0)1 34 90 43 97

[www.nortonabrasives.com](http://www.nortonabrasives.com)  
[www.youtube.com/NortonAbrasivesEMEA](http://www.youtube.com/NortonAbrasivesEMEA)

Norton is a registered trademark of Saint-Gobain Abrasives.  
Form # 3175



# ABRASIVE SOLUTIONS INDUSTRIAL APPLICATIONS 2017

SAINT-GOBAIN